

Higher Technological Institute  
Civil Engineering Department

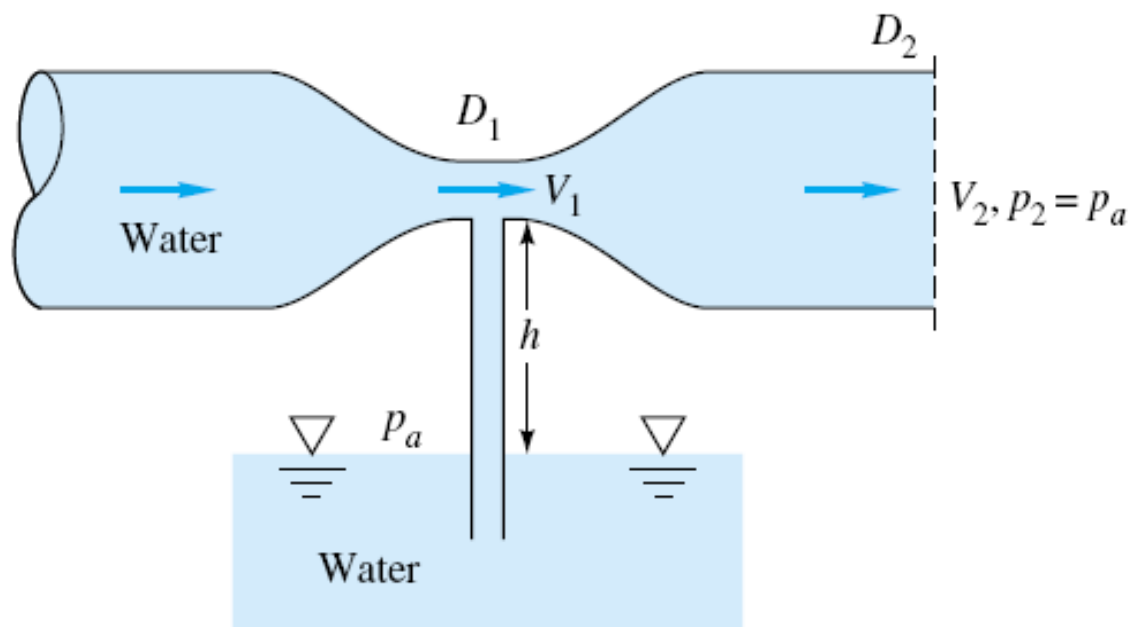

Lectures of  
**Fluid Mechanics**

Dr. Amir M. Mobasher



# Fluid Mechanics

*Dr. Amir Mobasher*  
*Department of Civil Engineering*  
*Faculty of Engineering – Al-Azhar University*

## Fluid concept

- **Fluid mechanics** is a division in applied mechanics related to the behaviour of **liquid** or **gas** which is either in rest or in motion.
- The study related to a fluid in rest or stationary is referred to **fluid static**, otherwise it is referred to as **fluid dynamic**.
- **Fluid** can be defined as **a substance which can deform continuously when being subjected to shear stress at any magnitude**. In other words, it can flow continuously as a result of shearing action. This includes any liquid or gas.

## Fluid concept

- Thus, with exception to solids, any other matters can be categorised as fluid.
- Examples of typical fluid used in engineering applications are **water**, **oil** and **air**.

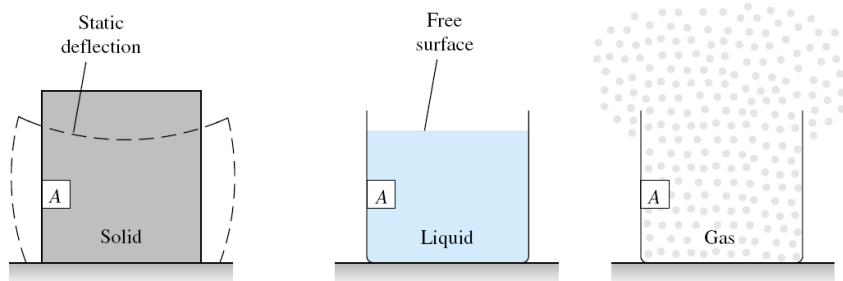

Dr. Amir Mobasher

3

## Units and Dimensions

### 1<sup>st</sup> Dimensions

Mass	Length	Time	Force
M	L	T	F

### Types of systems

- i- M-L-T system
- ii- F-L-T system

$$\text{Force} = \text{Mass} * \text{Acceleration}$$

Dr. Amir Mobasher

4

## Units and Dimensions

### 2<sup>nd</sup> Units

System / Quantity	Mass	Length	Time	Force
Standard International (S.I)	kg	m	sec	N
French System (c.g.s.)	gm	cm	sec	dyne
British (English)	slug	ft	sec	lb
Kilogram weight system	kg	m	sec	kg <sub>w</sub>

Dr. Amir Mobasher

5

## Units and Dimensions

### 1- Length (l)

$$1 \text{ ft} = 12 \text{ inch}$$

$$1 \text{ inch} = 2.54 \text{ cm}$$

*e.g.*

$$1 \text{ ft} = 12 * 2.54 \\ = 30.48 \text{ cm}$$

$$1 \text{ ft} = 0.3048 \text{ m}$$

$$\text{yard} = 3 \text{ ft}$$

$$\text{mile} = 1760 \text{ yard}$$

$$\text{mile} = 1760 * 3 * 0.3048$$

$$= 1609 \text{ m}$$

$$1 \text{ m} = 100 \text{ cm}$$

$$' \rightarrow \text{feet}, " \rightarrow \text{inch}$$

$$1 \text{ m} = \frac{1}{0.3048} \text{ ft}$$

$$= 3.28 \text{ ft}$$

Dr. Amir Mobasher

6

## Units and Dimensions

### 2- Mass (m)

$$\boxed{1 \text{ slug} = 14.59 \text{ Kg}} , \quad 1 \text{ ton} = 1000 \text{ Kg} , \quad 1 \text{ Kg} = 1000 \text{ gm}$$

### 3- Volume (V)

$$1 \text{ m}^3 = 1000 \text{ litre} = 10^6 \text{ cm}^3 , \quad 1 \text{ gallon} = 3.785 \text{ litre}$$

### 4- Velocity (V)

$$V = \frac{\text{length}}{\text{time}} = LT^{-1} \quad (\text{m/sec}) \quad \text{or} \quad (\text{ft/sec})$$

### 5- Acceleration (a)

$$a = \frac{\text{velocity}}{\text{time}} = \frac{dV}{dt} = LT^{-2}$$

Dr. Amir Mobasher

7

## Units and Dimensions

### 6- Gravitational acceleration (g)

$$\boxed{g = 9.81 \text{ m/sec}^2}$$

$$\boxed{g = 32.2 \text{ ft/sec}^2}$$

### 7- Force (F)

$$F = \text{mass} * \text{acceleration} = \boxed{MLT^{-2}}$$

$$N = \text{Kg} \cdot \text{m/sec}^2$$

$$\text{dyne} = \text{gm} \cdot \text{cm/sec}^2$$

$$\text{lb} = \text{slug} \cdot \text{ft/sec}^2$$

↑  
pound (lb)

$$1 N = 10^5 \text{ dyne}$$

$$\boxed{1 \text{ lb} = 4.44 \text{ N}}$$

$$1 \text{ Kg}_w = 9.81 \text{ N}$$

$$1 \text{ gm}_w = 981 \text{ dyne}$$

$$\boxed{1 \text{ Kg}_w = 2.205 \text{ lb}}$$

Dr. Amir Mobasher

8

## Units and Dimensions

### 8 - Density ( $\rho$ )

$$\rho = \frac{\text{Mass}}{\text{Volume}} = \frac{m}{V} = ML^{-3}$$

$$1 \text{ gm/cm}^3 = 1000 \text{ Kg/m}^3 = 1.94 \text{ slug/ft}^3$$

### Density of water

System	SI	C.G.S.	English
$\rho_w$	1000 Kg/m <sup>3</sup>	1 gm/cm <sup>3</sup>	1.94 slug/ft <sup>3</sup>

Dr. Amir Mobasher

9

## Units and Dimensions

### 9 - Specific Weight ( $\gamma$ )

$$\gamma = \frac{\text{Weight}}{\text{Volume}} = \frac{W}{V} = \frac{FL^{-3}}{MLT^{-2}} = ML^{-2}T^{-2}$$

$$\gamma = \rho g$$

### Specific weight of water

System	SI	C.G.S.	English
$\gamma_w$	9810 N/m <sup>3</sup>	981 dyne/cm <sup>3</sup>	62.4 lb/ft <sup>3</sup>

Dr. Amir Mobasher

10

## Units and Dimensions

10- Specific Volume =  $\frac{1}{\rho} = M^{-1}L^3$

11- Specific gravity (S.G.) = Relative density (r.d.)

$$S.G. = r.d. = \frac{\rho_{\text{liquid}}}{\rho_{\text{water}}} = \frac{\gamma_{\text{liquid}}}{\gamma_{\text{water}}} \quad (\text{no Units})$$

e.g. S.G. of Hg = 13.6

Mercury

$$\gamma_{\text{Hg}} = 13.6 \gamma_{\text{water}}$$

$$\begin{aligned} &\swarrow 13.6 * 9810 \quad \text{SI} \\ &\searrow 13.6 * 62.4 \quad \text{English} \end{aligned}$$

Dr. Amir Mobasher

11

## Units and Dimensions

12- Pressure (P) = Stress ( $\tau$ )

$$P = \tau = \frac{\text{Force}}{\text{Area}} = \rho gh = FL^{-2} = ML^{-1}T^{-2}$$

$$\text{Pa (Pascal)} = N/m^2$$

$$\text{Psi} = \text{pounds per square inch} \quad (\text{lb}/\text{inch}^2)$$

$$\text{Psf} = \text{pounds per square feet} \quad (\text{lb}/\text{ft}^2)$$

e.g. Convert  $P=1 \text{ Psi} \rightarrow \text{Psf}$

$$\therefore 1 \text{ ft} = 12 \text{ inch}$$

$$\therefore P = 1 \frac{\text{lb}}{\text{inch}^2} * (12)^2 \frac{\text{inch}^2}{\text{ft}^2} = 144 \text{ lb}/\text{ft}^2$$

$$\boxed{1 \text{ Psi} = 144 \text{ Psf}}$$

Dr. Amir Mobasher

12

## Units and Dimensions

13 - Discharge (Q) التصريف

$$Q = \frac{\text{Volume}}{\text{time}} = \frac{V}{t} = \text{Velocity} * \text{Area} = V.A = L^3 T^{-1}$$

$$1 \text{ m}^3/\text{sec} = 10^6 \text{ cm}^3/\text{sec}$$

Dr. Amir Mobasher

13

## Units and Dimensions

Quantity	Commonly used dimensions	BG (English) Units	SI units
Acceleration (a)	$LT^{-2}$	ft/sec <sup>2</sup>	m/s <sup>2</sup>
Force (F)	F or $MLT^{-2}$	lb (slug.ft/sec <sup>2</sup> )	N (kg.m/sec <sup>2</sup> )
Area (A)	$L^2$	ft <sup>2</sup>	m <sup>2</sup>
Density ( $\rho$ )	$ML^{-3}$	slug/ft <sup>3</sup>	kg/m <sup>3</sup>
Energy, work or quantity of heat	FL	ft.lb	N.m = Joule (J)
Flowrate (Q)	$L^3T^{-1}$	ft <sup>3</sup> /sec (cfs)	m <sup>3</sup> /s
Frequency	$T^{-1}$	cycle/sec (sec <sup>-1</sup> )	Hz (hertz, s <sup>-1</sup> )
Kinematic viscosity ( $\nu$ )	$L^2T^{-1}$	ft <sup>2</sup> /sec	m <sup>2</sup> /s
<b>Power</b>	<b><math>FLT^{-1}</math></b>	<b>ft.lb/sec</b>	<b>N.m/s = Watt (W)</b>
Pressure (p)	$FL^{-2}$	lb/in <sup>2</sup> (psi)	N/m <sup>2</sup> = Pascal (Pa)
Specific weight ( $\gamma$ )	$FL^{-3}$	lb/ft <sup>3</sup> (pcf)	N/m <sup>3</sup>
Velocity (V)	$LT^{-1}$	ft/sec (fps)	m/s
Viscosity ( $\mu$ )	$FTL^{-2}$	lb.sec/ft <sup>2</sup>	N.s/m <sup>2</sup>
Volume ( $\nabla$ )	$L^3$	ft <sup>3</sup>	m <sup>3</sup>

Dr. Amir Mobasher

14



## Units and Dimensions

14 - Momentum = mass \* Velocity = Force \* time

15 - Energy (E) = Work = Torque (T) = Moment

Work = Force \* distance = F.L =  $ML^2T^{-2}$

Joule = N.m

16 - No of revolutions (N) = (n) Speed of Rotation.

N = no. of revolutions/minute (r.p.m.)

n = no. of revolutions/second (r.p.s)

Dr. Amir Mobasher

15

## Units and Dimensions

17 - Angular Velocity ( $\omega$ ) السرعة الزاوية

$\omega = \frac{\theta}{t} = \frac{2\pi N}{60} = 2\pi n$  (rad/sec)

$V = \omega r$  (m/sec) or (ft/sec)



18 - Power (P)

$P = \text{Force} * \text{Velocity} = FLT^{-1} = ML^2T^{-3}$

Watt = N.m/sec      HP = Horsepower = Watt/735

Dr. Amir Mobasher

16

## Fluids Properties

### - Surface tension ( $\sigma$ )

Surface tension ( $\sigma$ ): A liquid's ability to resist tension

### - Capillarity

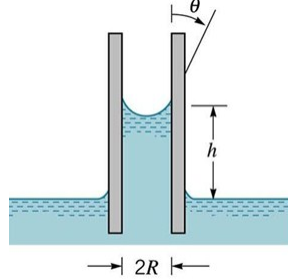

Adhesion > Cohesion

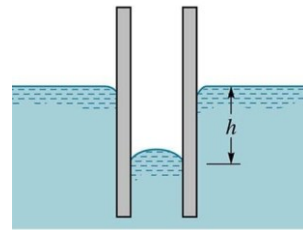

Cohesion > Adhesion

**Cohesion:** Inner force between liquid molecules.

Dr. Amir Mobasher **Adhesion:** Attraction force between liquids, and a solid surface.

## Fluids Properties

### - Capillarity

$$\sigma (\pi d) \cos \theta = \frac{\pi d^2}{4} * h * \gamma$$

$$h = \frac{4\sigma \cos \theta}{\gamma d}$$

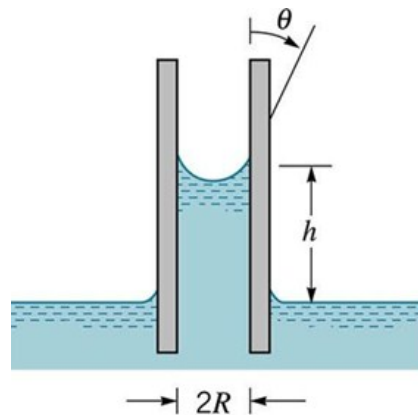

## Fluids Properties

### - Water droplets

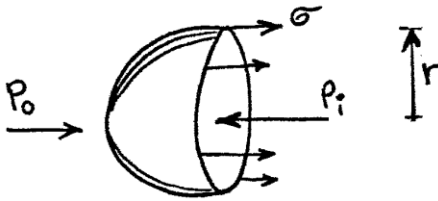

$$(P_i - P_o) \pi r^2 = \sigma (2\pi r)$$

$$P_i - P_o = \frac{2\sigma}{r}$$

or

$$\Delta P = \frac{4\sigma}{d}$$

Dr. Amir Mobasher

19

## Fluids Properties

### - Viscosity

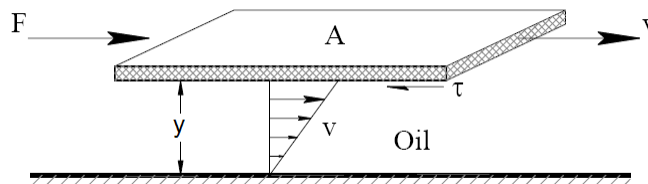

$$F \propto V$$

$$F \propto \frac{1}{y}$$

$$F \propto A$$

$$\frac{F}{A} \propto \frac{V}{y}$$

$$\tan \theta = \frac{dV}{dy}$$

Dr. Amir Mobasher

$$\tau = \mu \frac{dV}{dy}$$

Shear stress

viscosity

velocity gradient

Newton's eqn of Viscosity

$$F = \mu A \frac{dV}{dy}$$

Friction force

20

## Fluids Properties

### - Viscosity

$$\begin{aligned} \mu &= \tau \frac{y}{V} = \frac{ML^{-1}T^{-1}}{m \cdot sec} = \frac{FL^{-2}T}{\frac{N}{m^2} \cdot sec} = Pa \cdot s \\ &= \frac{gm}{cm \cdot sec} = \frac{dyne \cdot sec}{cm^2} = \text{Poise} \\ &= \frac{slug}{ft \cdot sec} = \frac{lb \cdot sec}{ft^2} \end{aligned}$$

$$\boxed{\text{Poise} = 0.1 \text{ Pa} \cdot \text{s}}$$

$$\begin{aligned} \mu_{\text{water}} &\approx 0.001 \text{ Pa} \cdot \text{s} \\ &\approx 0.01 \text{ poise} \end{aligned}$$

Dr. Amir Mobasher

21

## Fluids Properties

### - Kinematic Viscosity ( $\nu$ )

$$\boxed{\nu = \frac{\mu}{\rho}} = \frac{ML^{-1}T^{-1}}{ML^{-3}} = \boxed{L^2 T^{-1}}$$

$$\begin{aligned} \nu &= (cm^2/sec) = \text{stoke} \\ &= (m^2/sec) \text{ or } (ft^2/sec) \end{aligned}$$

$$\boxed{\text{Stoke} = 10^{-4} m^2/sec}$$

$$\nu_{\text{water}} = 10^{-6} m^2/sec = 10^{-2} \text{ stoke}$$

Dr. Amir Mobasher

22

## Applications of Viscosity

### 1- Plate moving with uniform velocity

a- against a horizontal plane

Resistance (Friction force) =  $\tau \cdot A$

$$F = \mu \frac{V}{y} A$$

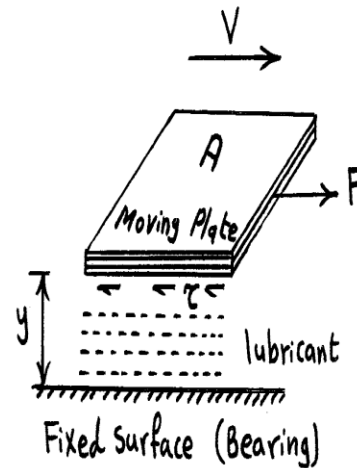

Dr. Amir Mobasher

23

## Applications of Viscosity

### 1- Plate moving with uniform velocity

b- between 2 Planes

$$F = \tau_1 A + \tau_2 A$$

$$\tau_1 = \mu \frac{V}{y_1}$$

$$\tau_2 = \mu \frac{V}{y_2}$$

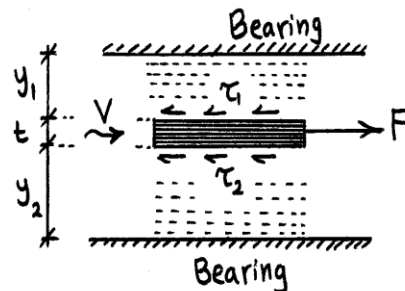

Dr. Amir Mobasher

24

## Applications of Viscosity

### 1- Plate moving with uniform velocity

C - against an inclined Plane

at uniform velocity  $\Rightarrow (\Sigma F = 0)$

$$\boxed{W \sin \theta = \mu \frac{V}{y} A}$$

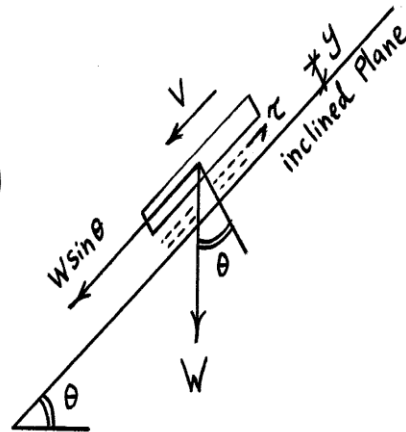

Dr. Amir Mobasher

25

## Applications of Viscosity

### 2- Cylinder moving with uniform velocity

a - Inner cylinder moving horizontally

$$F = \mu \frac{V}{y} A$$

$$A = 2\pi r_1 L$$

$$\boxed{F = \mu \frac{V}{r_2 - r_1} 2\pi r_1 L}$$

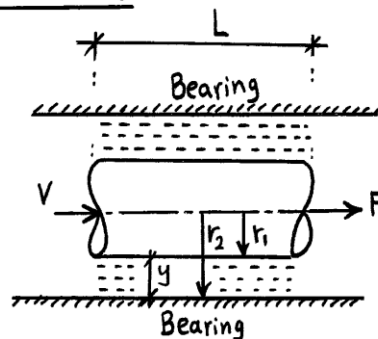

Dr. Amir Mobasher

26

## Applications of Viscosity

### 2- Cylinder moving with uniform velocity

b- Inner cylinder moving vertically under gravity

$$W = \mu \frac{V}{y} A$$

$$A = 2\pi r_1 L$$

$$W = \mu \frac{V}{r_2 - r_1} 2\pi r_1 L$$

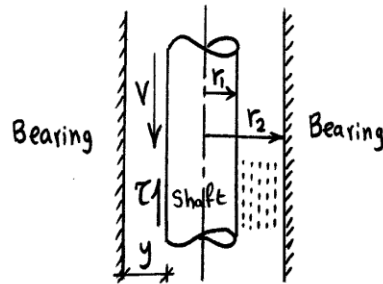

Dr. Amir Mobasher

27

## Applications of Viscosity

### 2- Cylinder moving with uniform velocity

c- Outer moving and the inner fixed

$$W = \mu \frac{V}{y} A$$

$$A = 2\pi r_2 L$$

$$y = r_2 - r_1$$

$$W = \mu \frac{V}{r_2 - r_1} 2\pi r_2 L$$

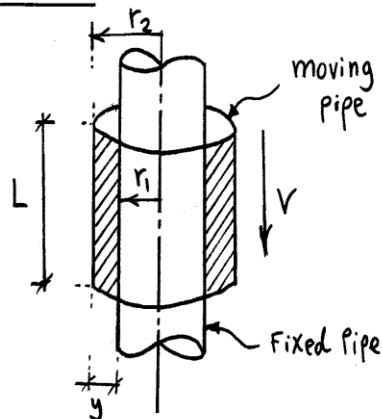

Dr. Amir Mobasher

28

# 3

## Hydrostatic Pressure

$$\text{Pressure} = \frac{\text{Force}}{\text{Area}} = \frac{\rho g h A}{A} = \gamma h$$

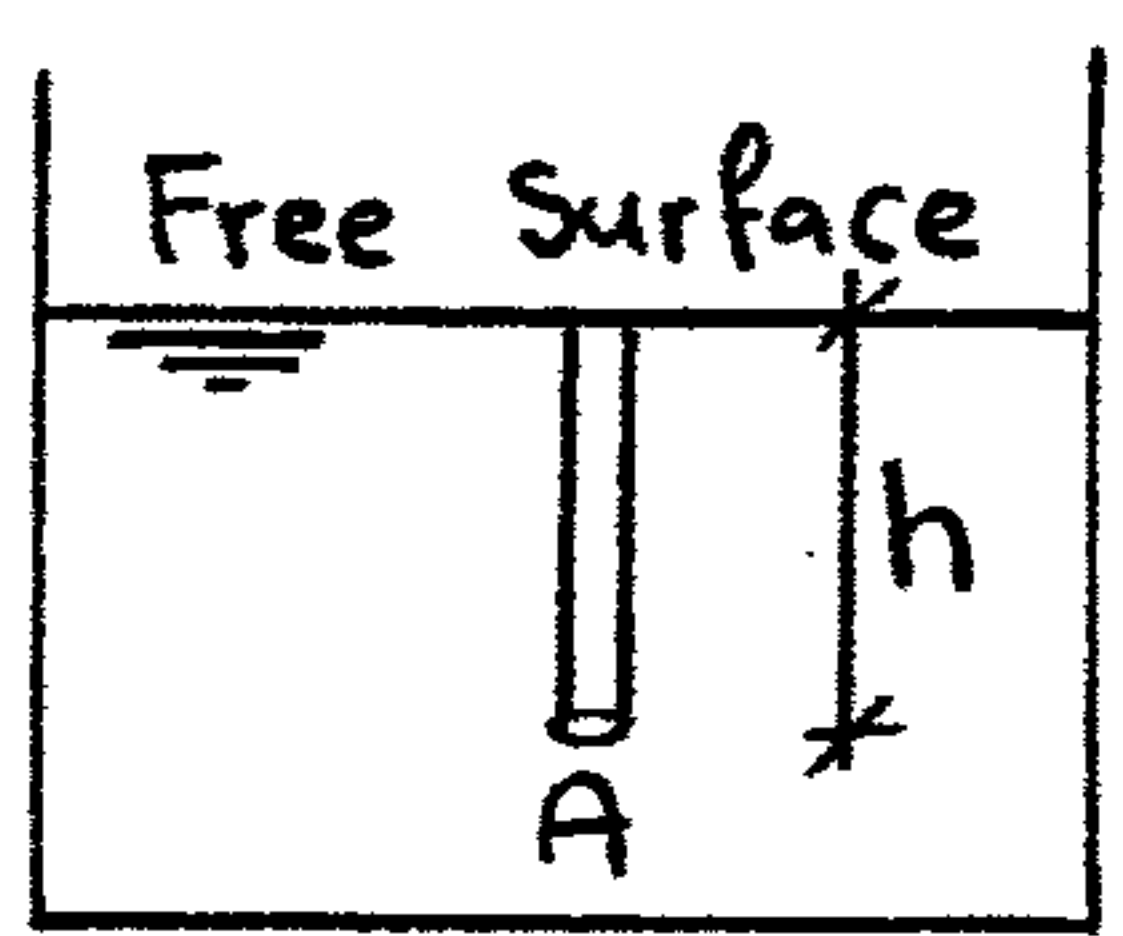

$$P = \gamma H$$

Pascal's hydrostatic equation

Pressure      Specific weight      Pressure head

units  $\Rightarrow$        $N/m^2 = Pa$        $lb/ft^2 = Psf$        $lb/inch^2 = Psi$

e.g.  $P_2 > P_1$

$$P_2 = P_1 + \gamma_f h$$

$$\therefore S.G. = \frac{\gamma_f}{\gamma_w}$$

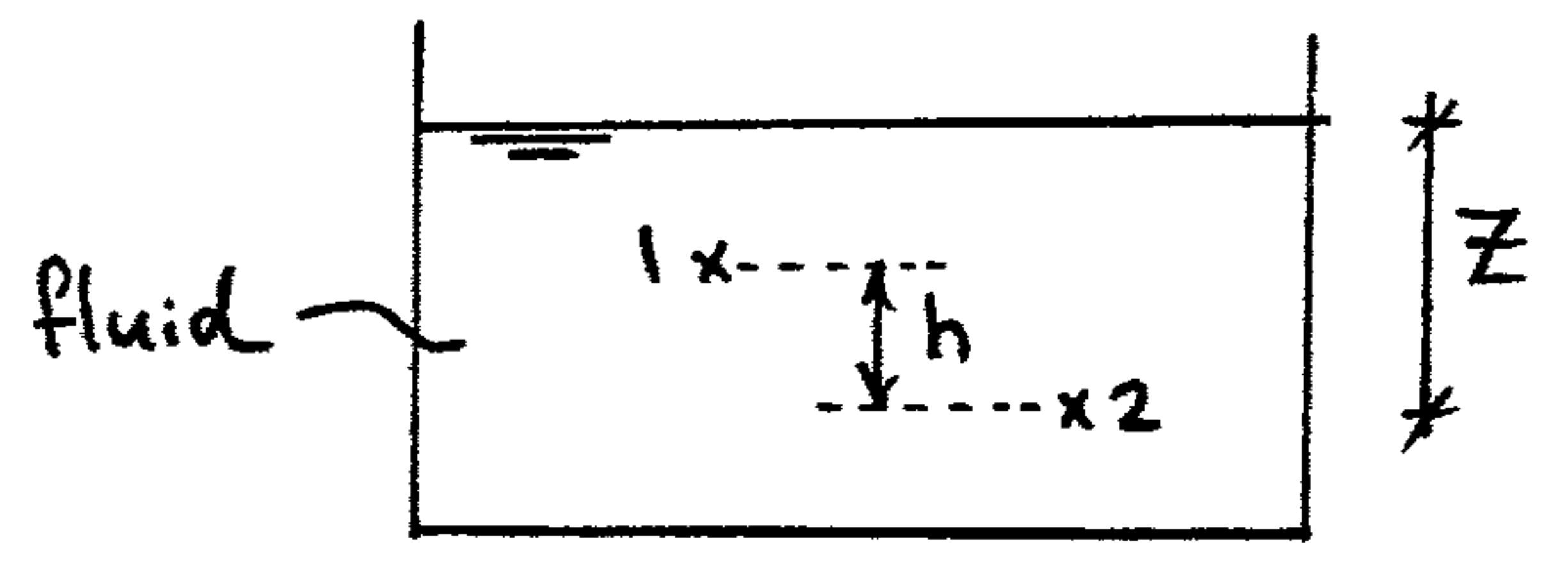

$$P_2 = P_1 + S.G. \gamma_w h$$
$$P_1 = P_2 - S.G. \gamma_w h$$

$$P_2 = \gamma_f Z \quad (\text{gage})$$
$$P_2 = P_{atm} + \gamma_f Z \quad (\text{absolute})$$

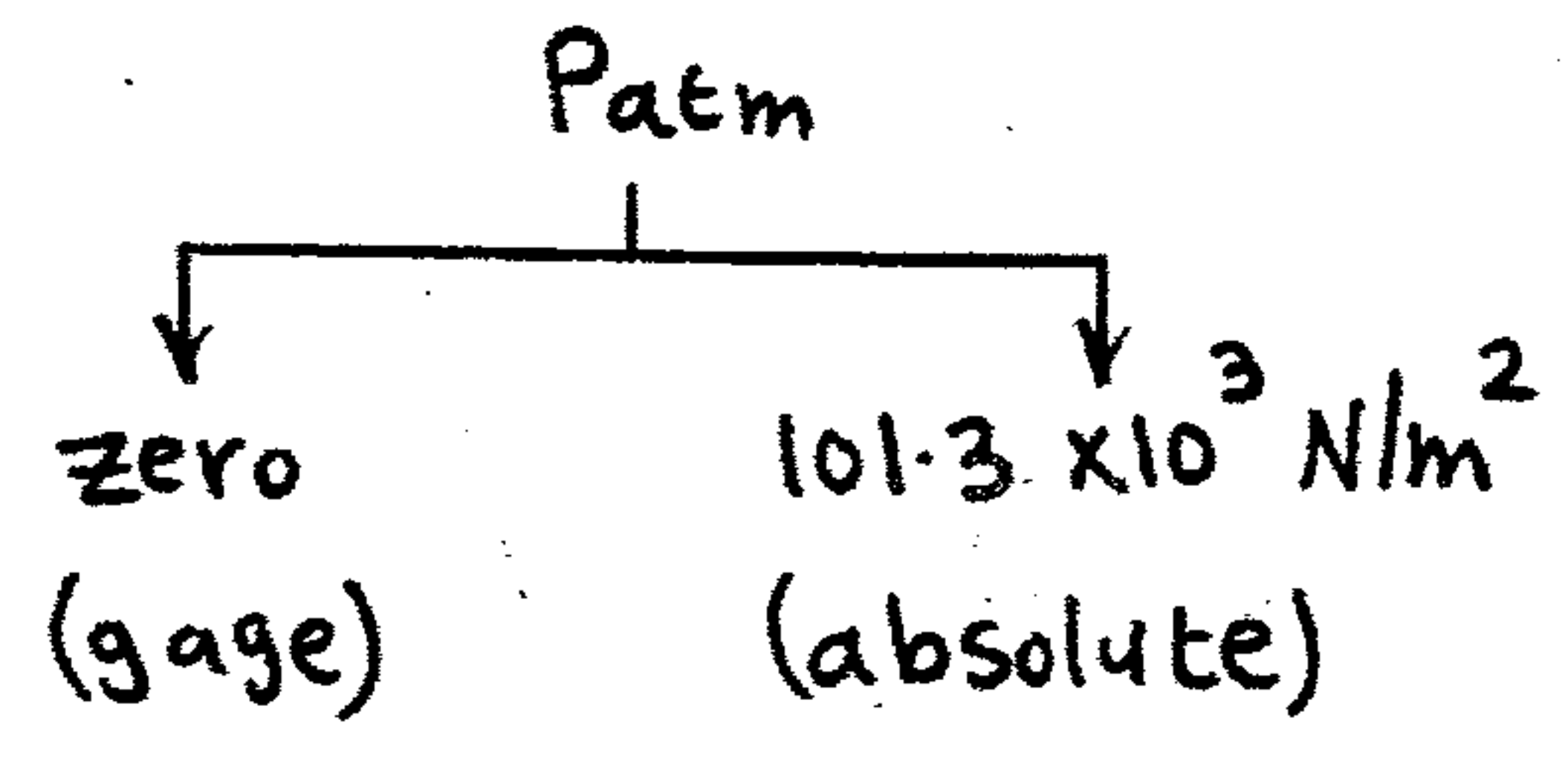

### Gauge Pressure

It is the pressure measured by an instrument, in which the atmospheric pressure is taken as a datum

### Absolute Pressure

It is the sum of the atmospheric and gauge pressure

$$P_{abs} = P_{atm} + P_{gage}$$



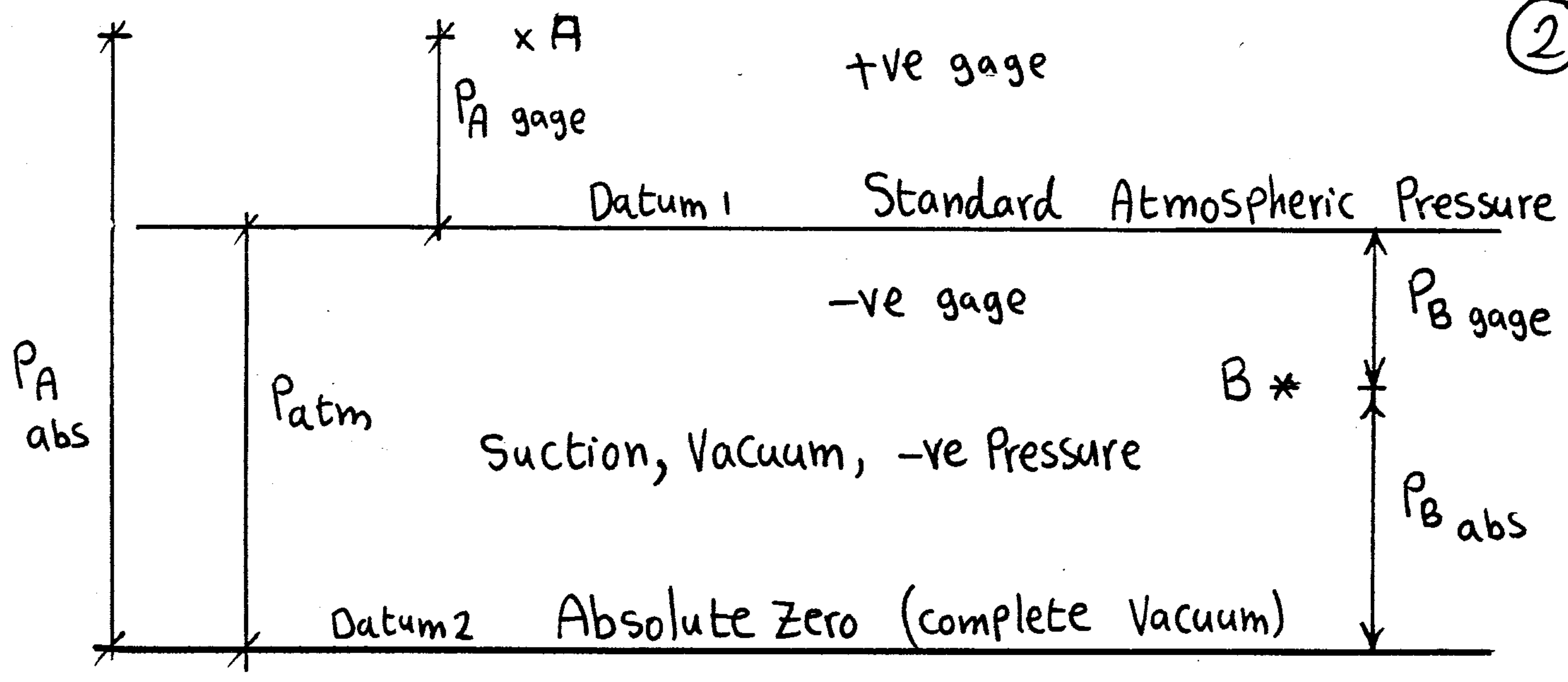

e.g//

$$P_A = 20 \text{ KPa (gage)}$$

$$P_A = 101.3 + 20 = 121.3 \text{ KPa (absolute)}$$

$$P_B = -40 \text{ KN/m}^2$$

$$= 40 \text{ KN/m}^2 \text{ vacuum (gage)}$$

$$= 40 \text{ KN/m}^2 \text{ suction (gage)}$$

$$P_B = 101.3 - 40 = 61.3 \text{ KN/m}^2 \underline{a} \text{ (absolute)}$$

شروط تساوي الضغط عند نقطتين (المتوى الفاصل)

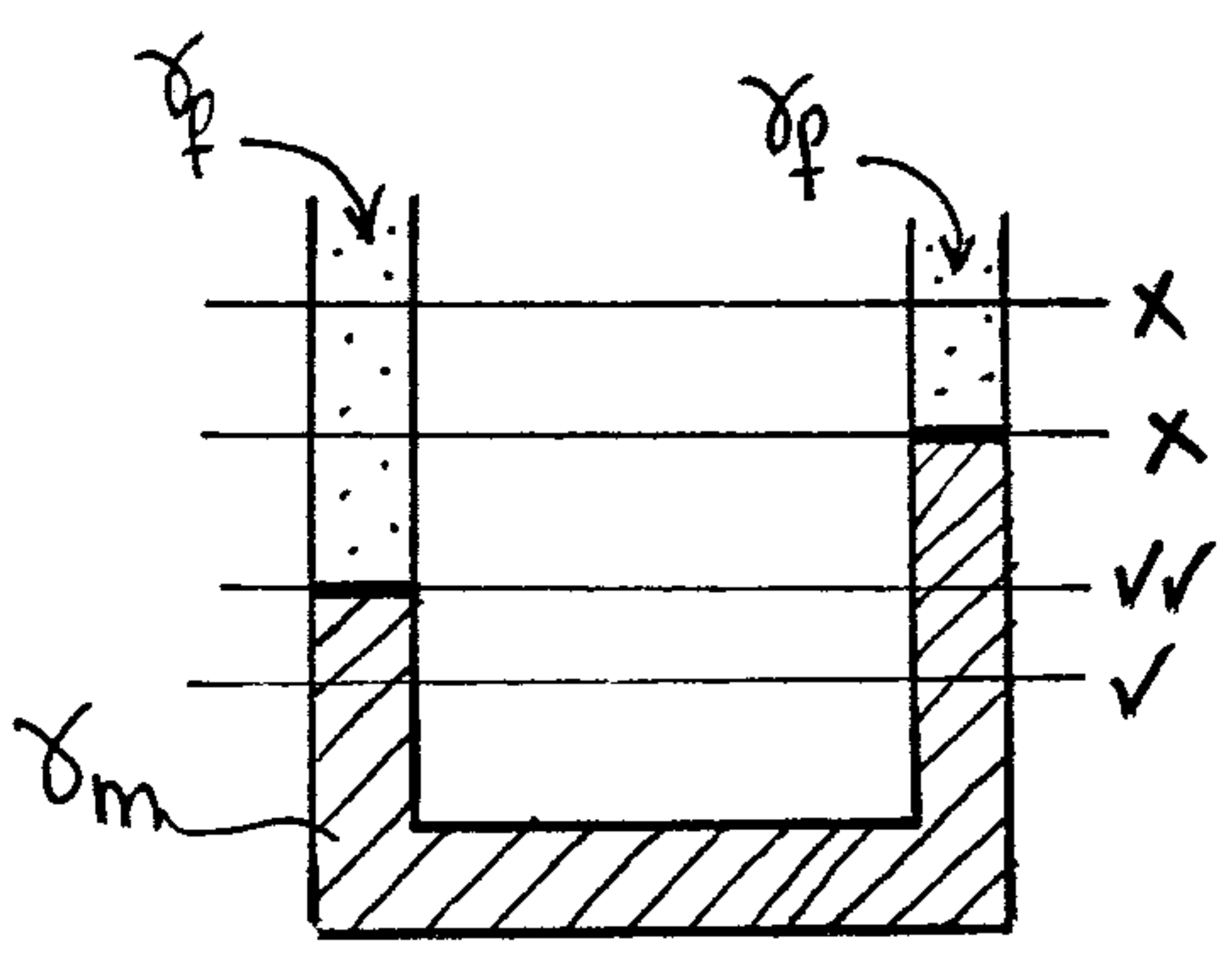

1- أن تقع النقطتين في نفس السائل

2- السائل سائل

3- السائل متصل

4- المتوى أفقى

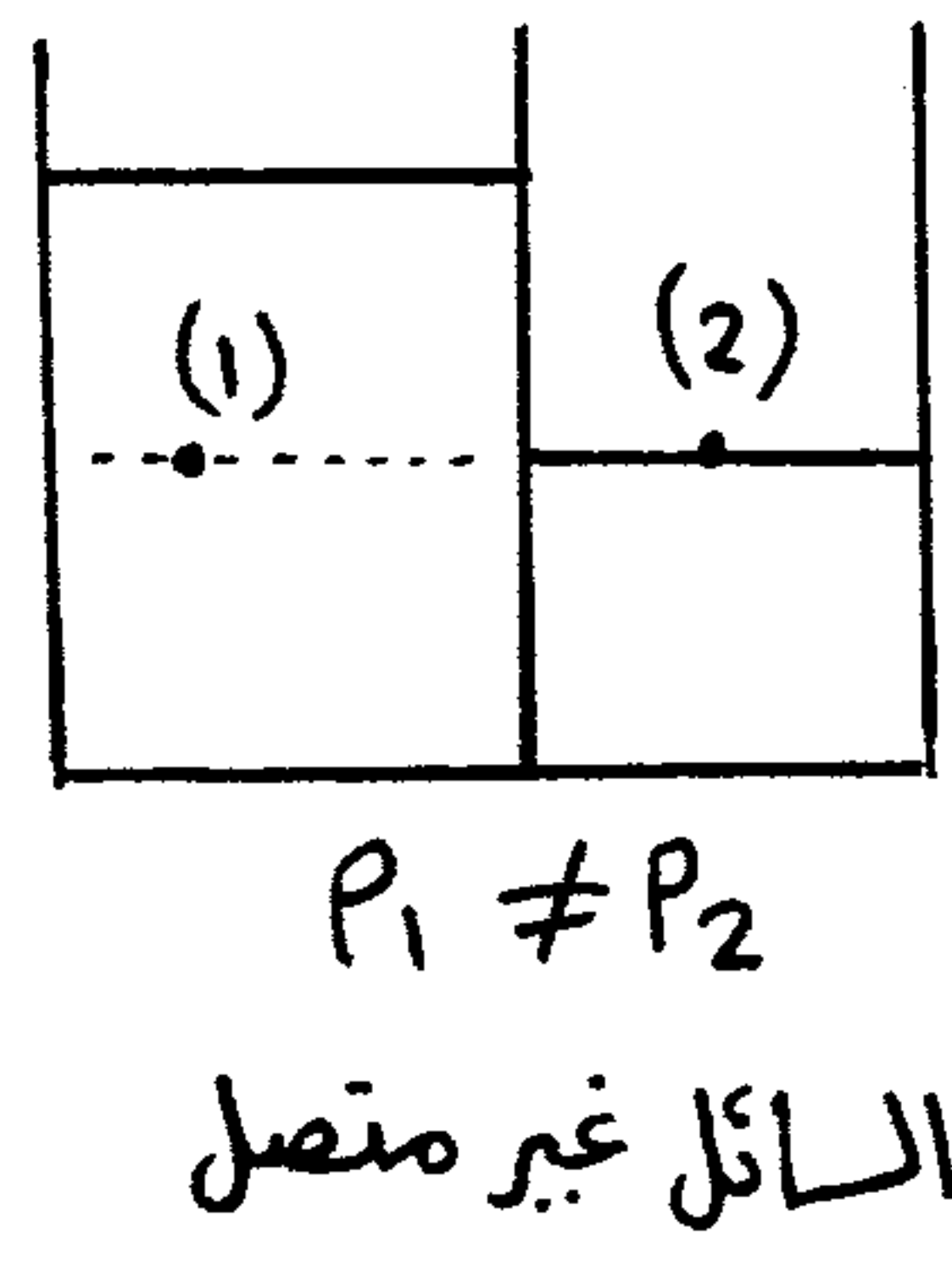
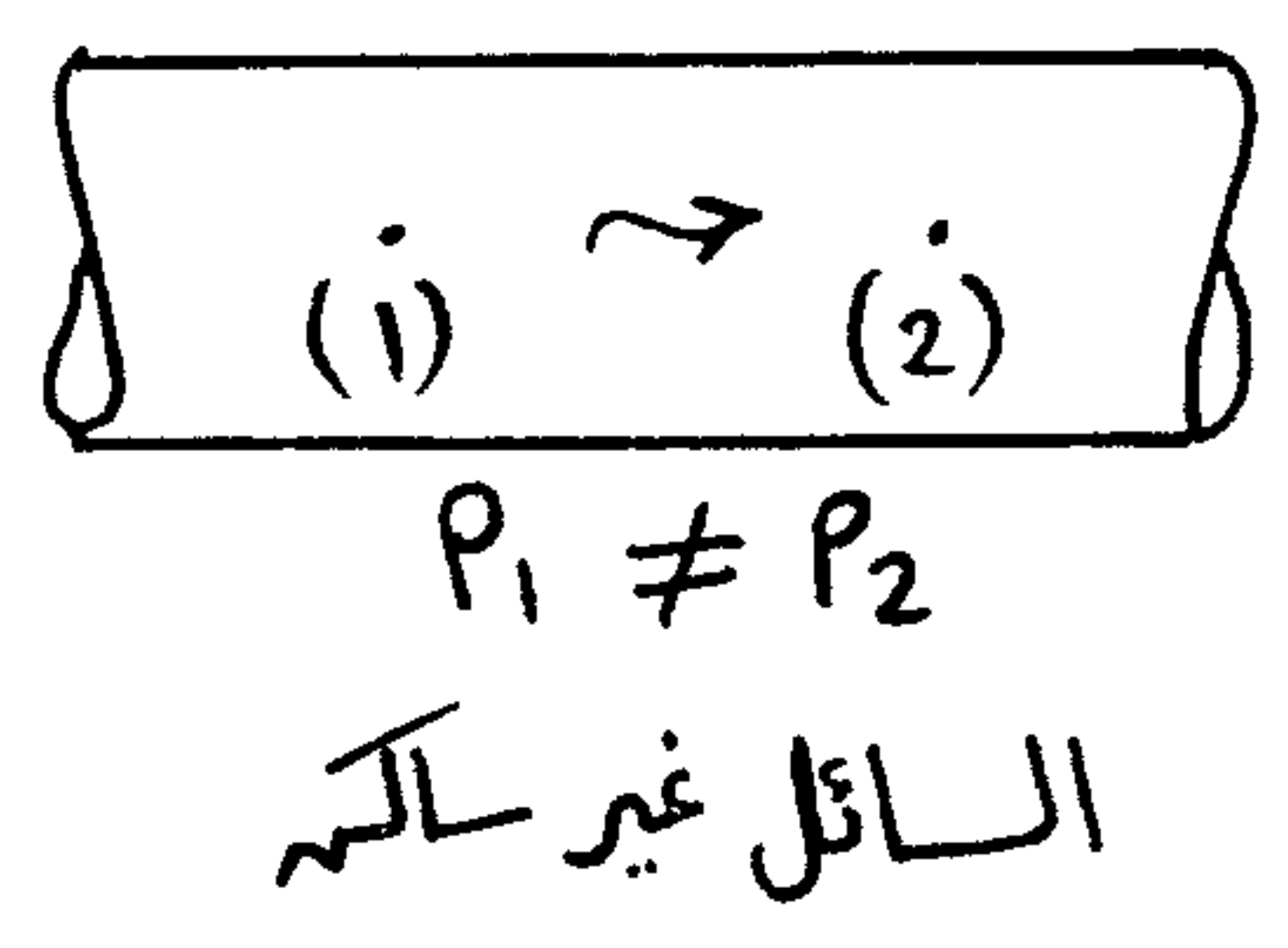

Standard Values of  $P_{atm}$

$$\begin{aligned}
 P_{atm} &= 0.76 \text{ m Hg} = 0.76 \gamma_{Hg} = 0.76 \times 13.6 \times 9810 \\
 &= 10.33 \text{ m Water} = 10.33 \gamma_w = 10.33 \times 1 \times 9810 \\
 &= 101.3 \times 10^3 \text{ N/m}^2 \text{ (Pa)} \approx 1 \times 10^5 \text{ N/m}^2 = 1 \text{ bar} \\
 &= 14.7 \text{ Psi}_a = 14.7 \times 144 \text{ lb/ft}^2 \text{ (Psf)} \\
 &= 1 \text{ atmosphere} = 34 \text{ ft water} \\
 &= \text{Zero (gauge)} = 1.03 \text{ kg}_w/\text{cm}^2
 \end{aligned}$$

Pressure measurements

1- Barometer

The barometer measures the atmospheric pressure at its location in absolute units

$$P_{atm} = \text{Barometric pressure} = \text{local atmospheric pressure}$$

$$P_{atm} = \text{Standard value} = 101.3 \times 10^3 \text{ Pa}$$

لوئير مٿي

a- Mercury Barometer

\* It measures the atmospheric Pressure in absolute units

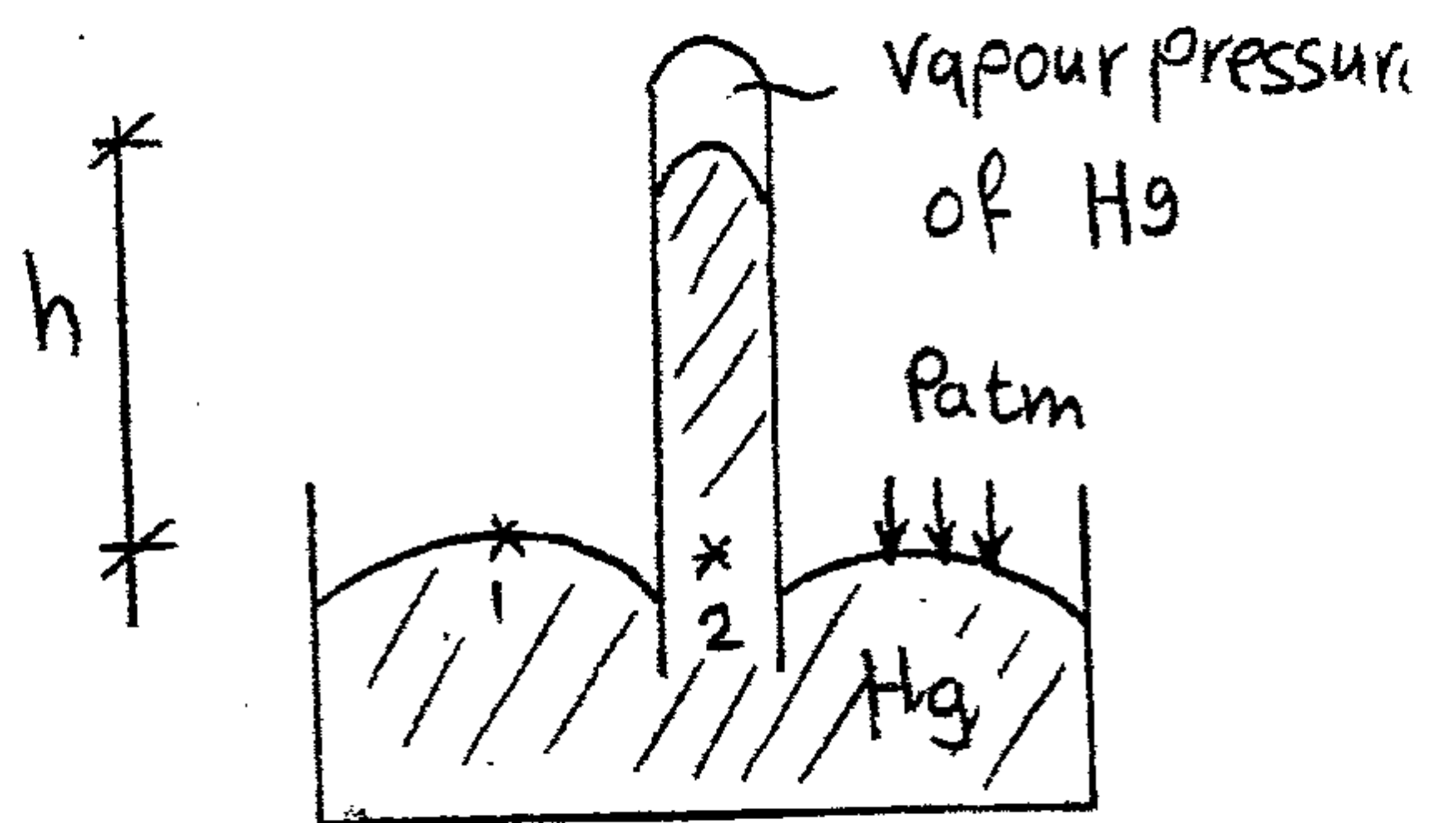

\* When a tube filled with Mercury is inverted in a reservoir filled with Mercury, the Mercury drops until its height is balanced by the atmospheric Pressure

$$P_{atm} = \gamma_{Hg} h$$

b- Aneroid Barometer

It measures the difference between the atmospheric Pressure and an evacuated cylinder

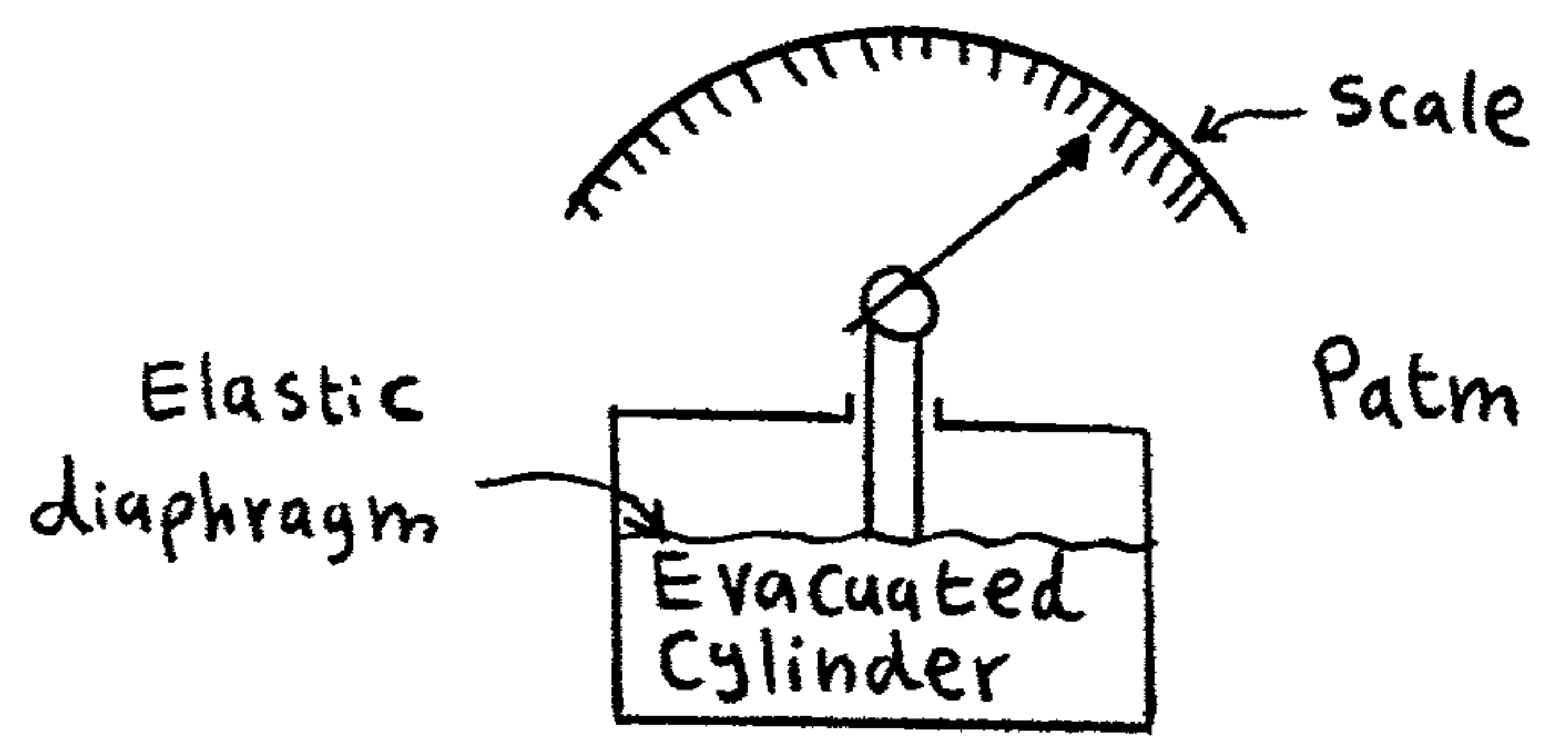

2- Pressure gauges

Bourdon gauge

It measures the Pressure relative to the Pressure surrounding the gauge

$$P_{gauge} = P_{in} - P_{out}$$

$$\text{If } P_{in} = P_{out} \Rightarrow \text{Reading} = 0$$

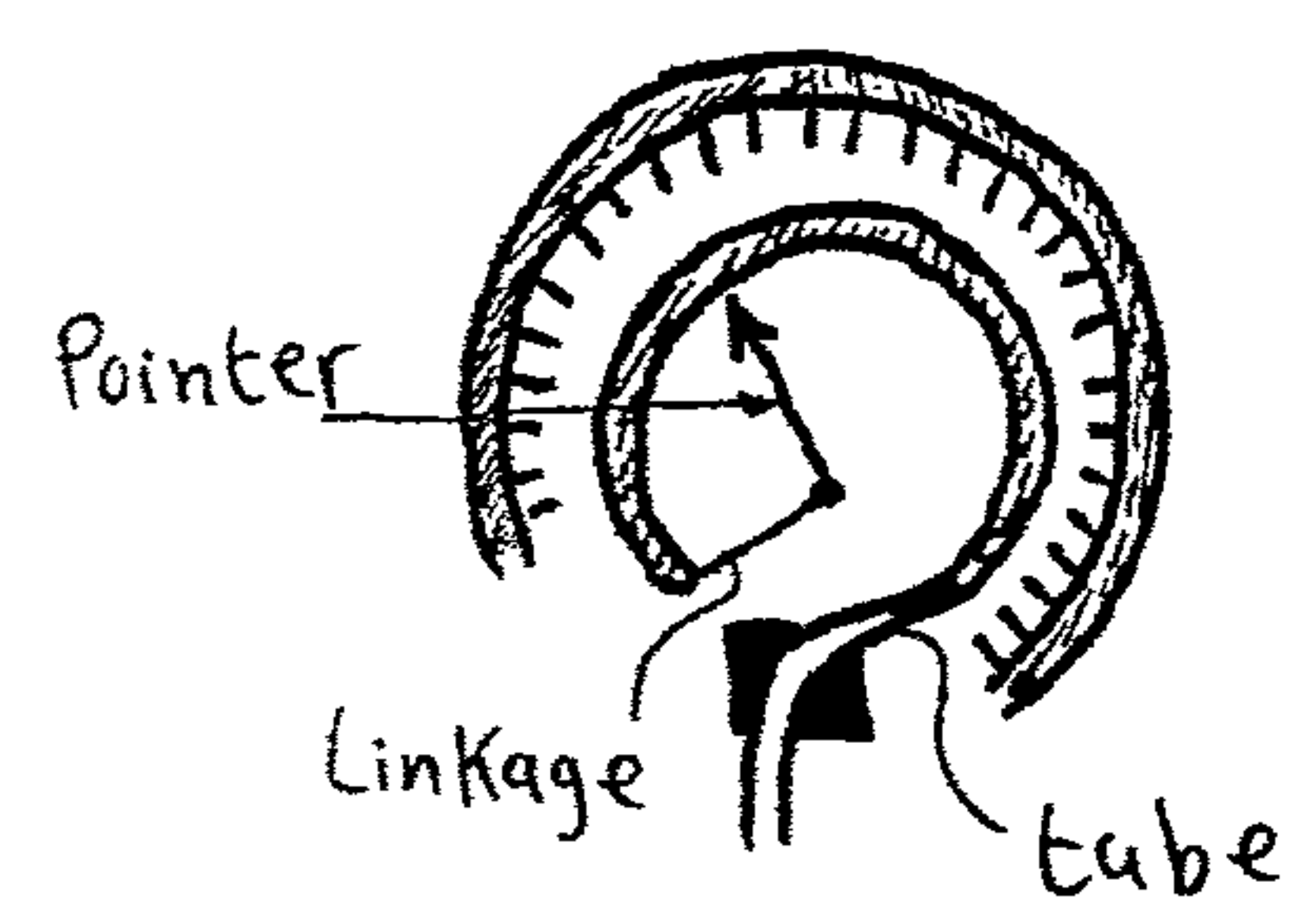

3- Piezometer

القياس والواحد

It measures Positive gauge Pressures of low magnitudes

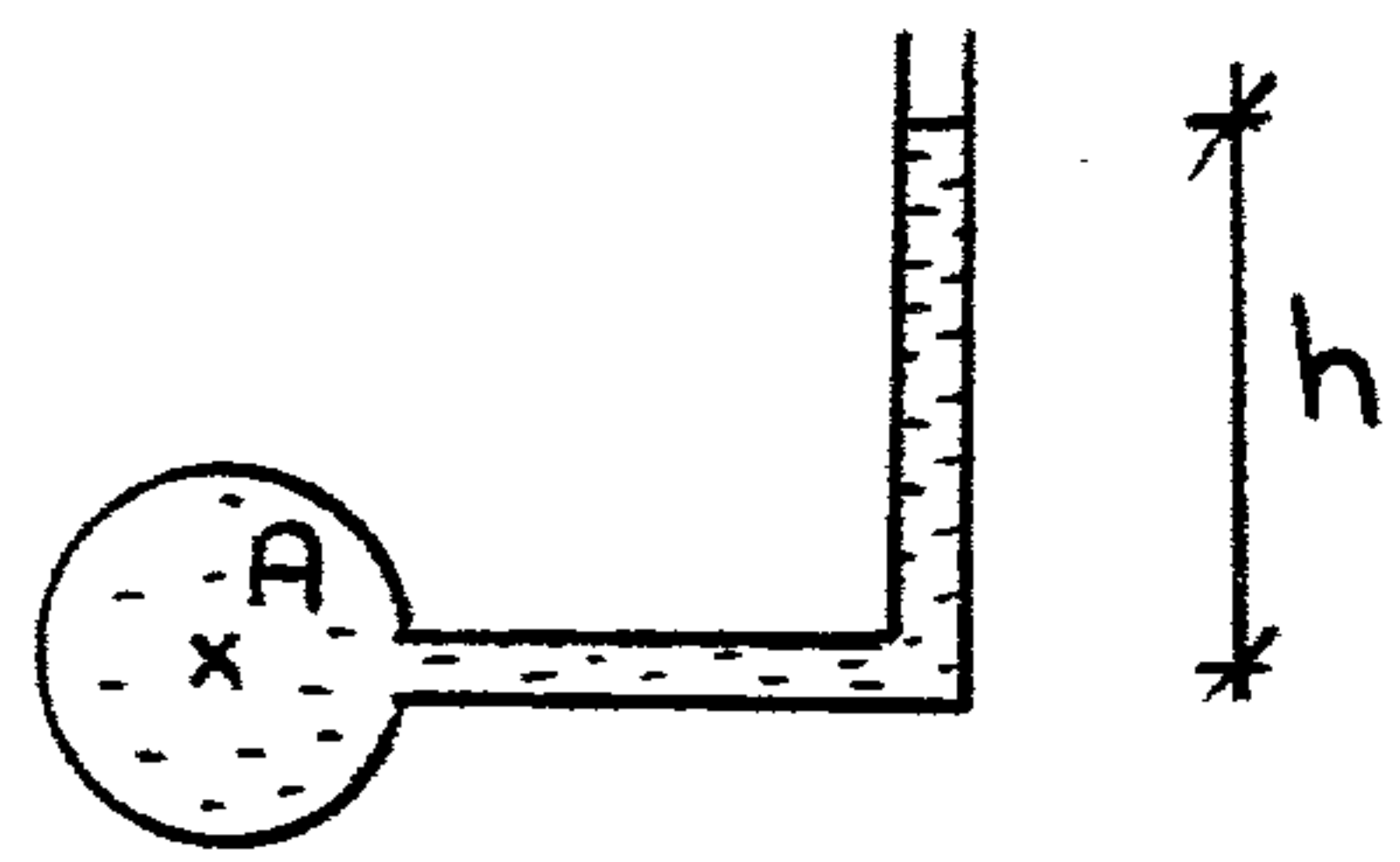
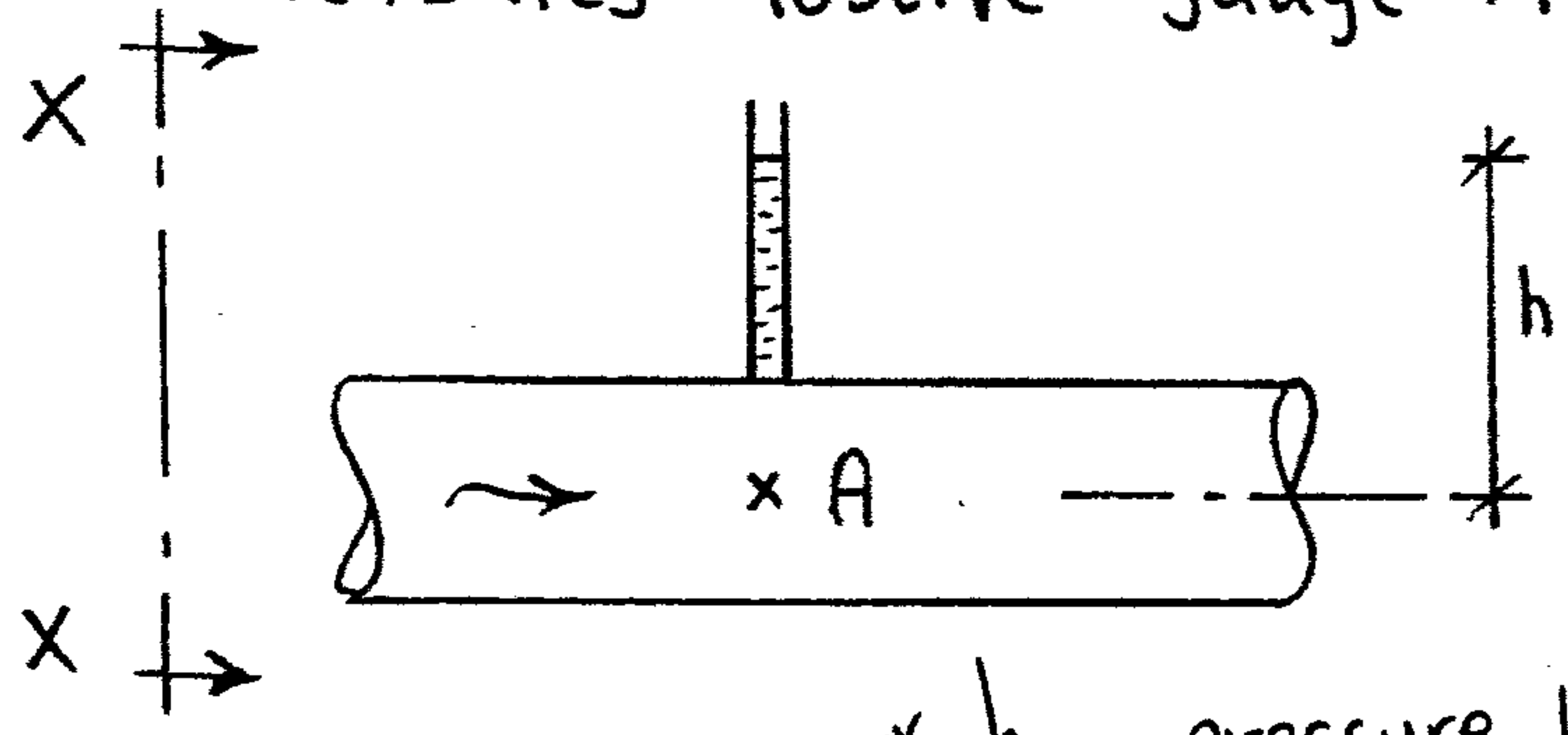

\* h = pressure head

Limitations

- a- Piezometers does not work for negative Pressures
- b- It is impractical to measure large Pressure (we need a very long tube)

## Pressure head

(5)

Pressure head is the height of a column of fluid that will produce the given intensity of Pressure

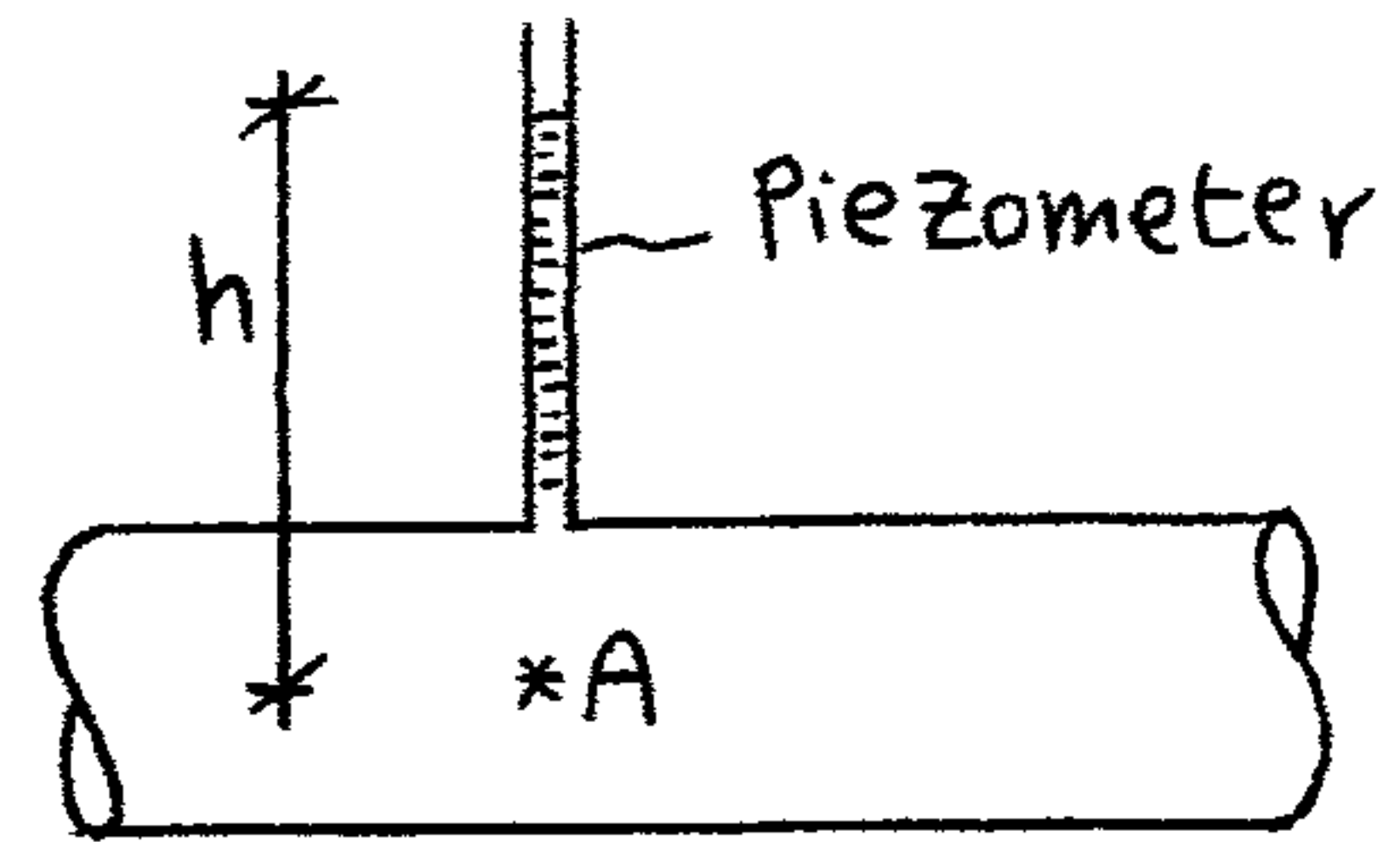

$$h = \frac{P}{\gamma} = \text{Pressure head}$$

When a Piezometer is inserted in a tube the height of which the fluid rises is the Pressure head.

### 4- Manometers

استخدام السائلين

It measures fluid pressures by using different fluids which may be heavier or lighter than the fluid concerned

#### a- simple manometer

$$P_1 = P_2$$

$$P_1 = P_A + \gamma_f h_1$$

$$P_2 = P_{atm} + \gamma_m h_2$$

$$\Rightarrow P_A = P_{atm} + \gamma_m h_2 - \gamma_f h_1$$

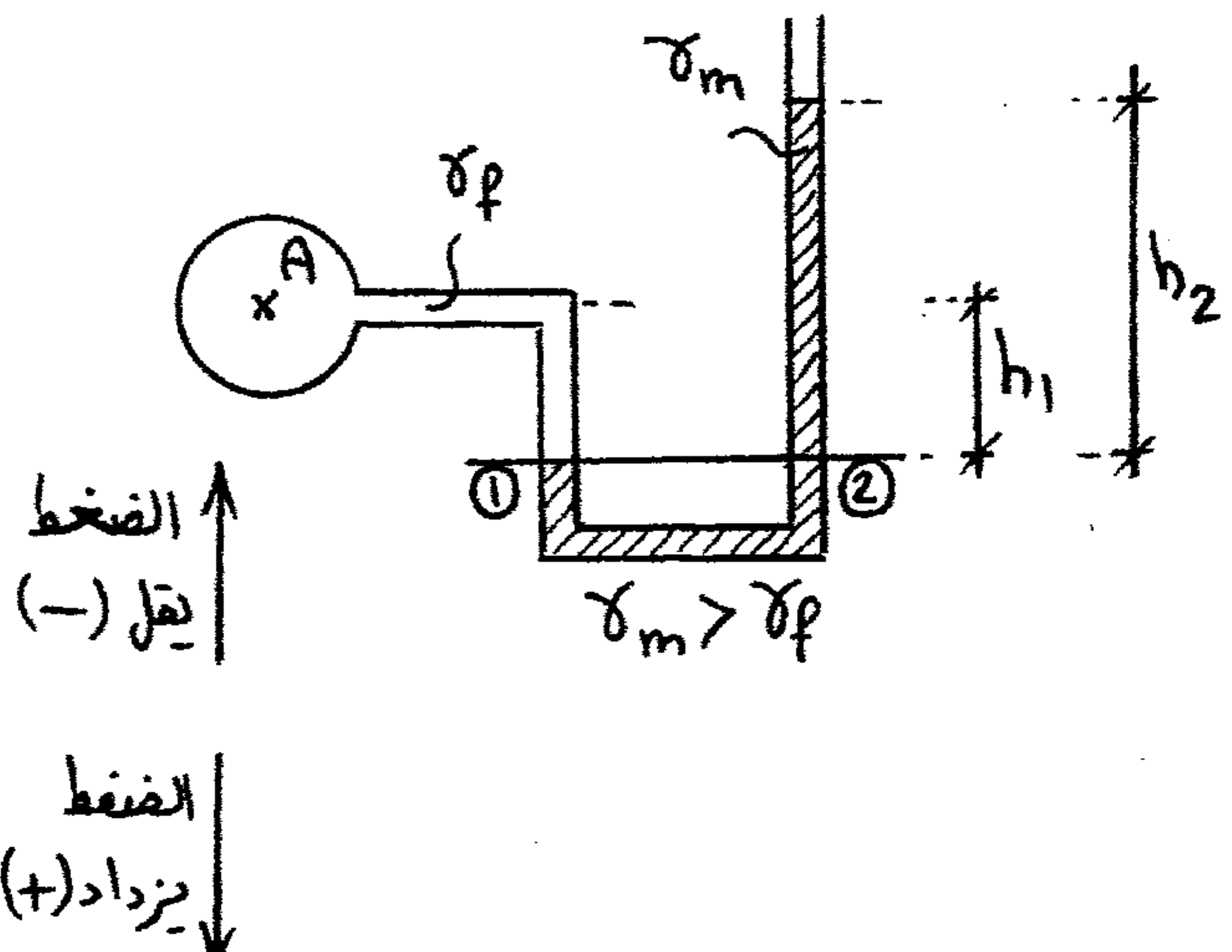

### Differential manometers are used

- When only the difference between two pressures are desired

### U-tube manometer is used

- When there is a big pressure difference
- A heavy liquid such as mercury is used

### Inverted U-tube manometer is used

- When there is a small pressure difference
- A light liquid such as oil is used.

b- Differential manometer

$$P_1 = P_2$$

$$P_1 = P_A + \gamma_f h_3$$

$$P_2 = P_B + \gamma_f h_2 + \gamma_m h_1$$

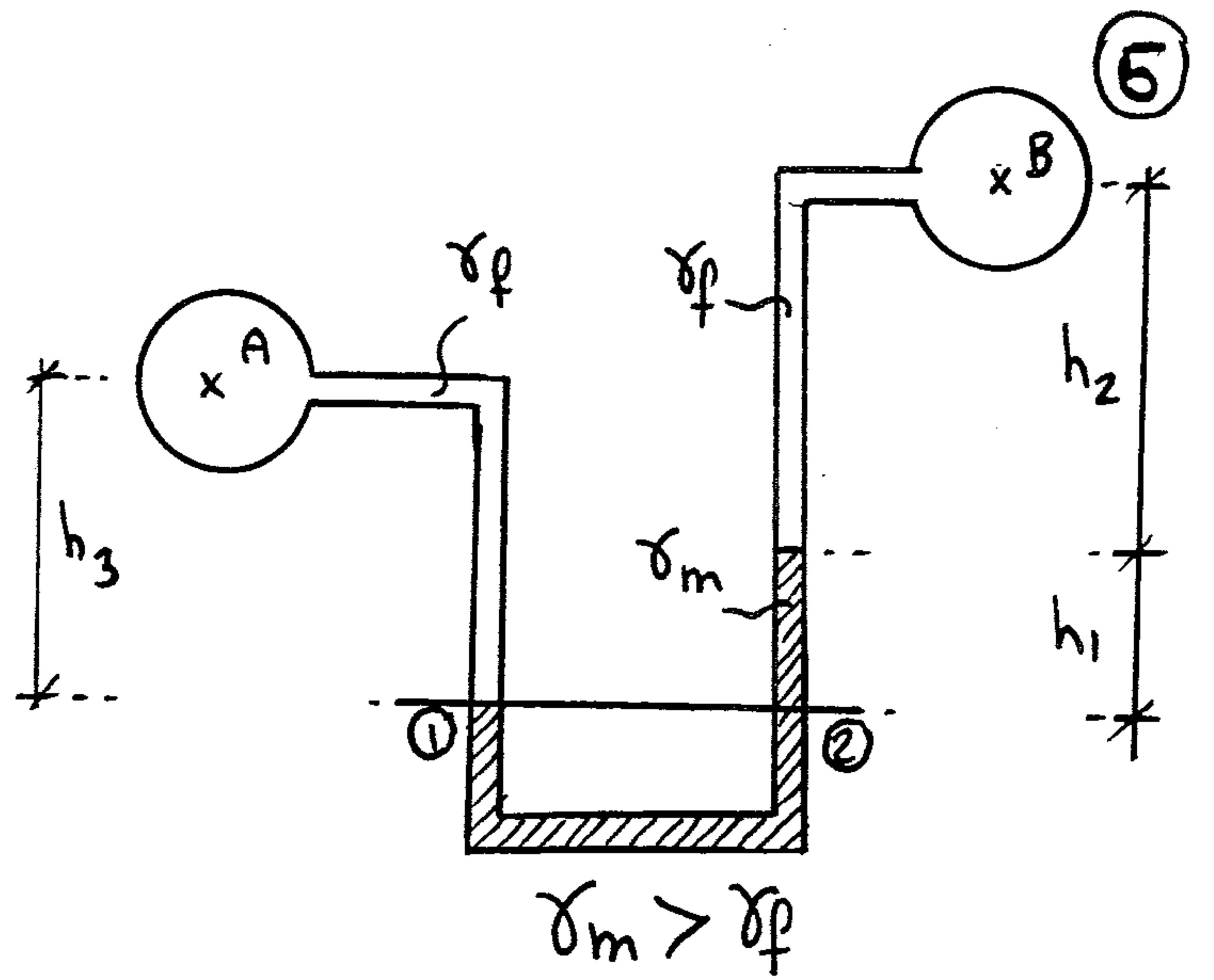

c- Inverted U tube Manometer

$$P_1 = P_2$$

$$P_1 = P_A - \gamma_f h_2 - \gamma_m h_1$$

$$P_2 = P_B - \gamma_f h_3$$

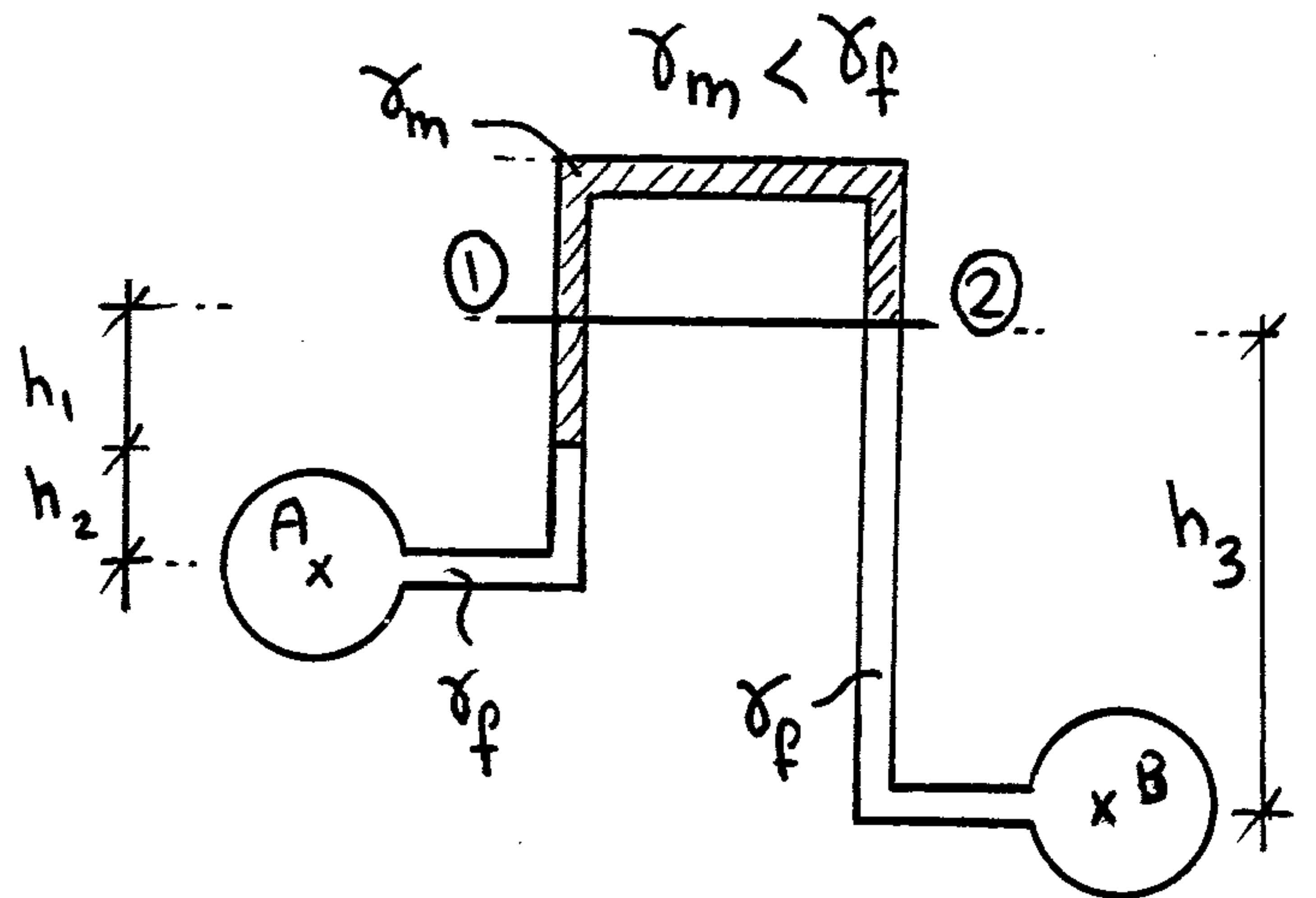

d- Micromanometer

i- Vertical tube Manometer

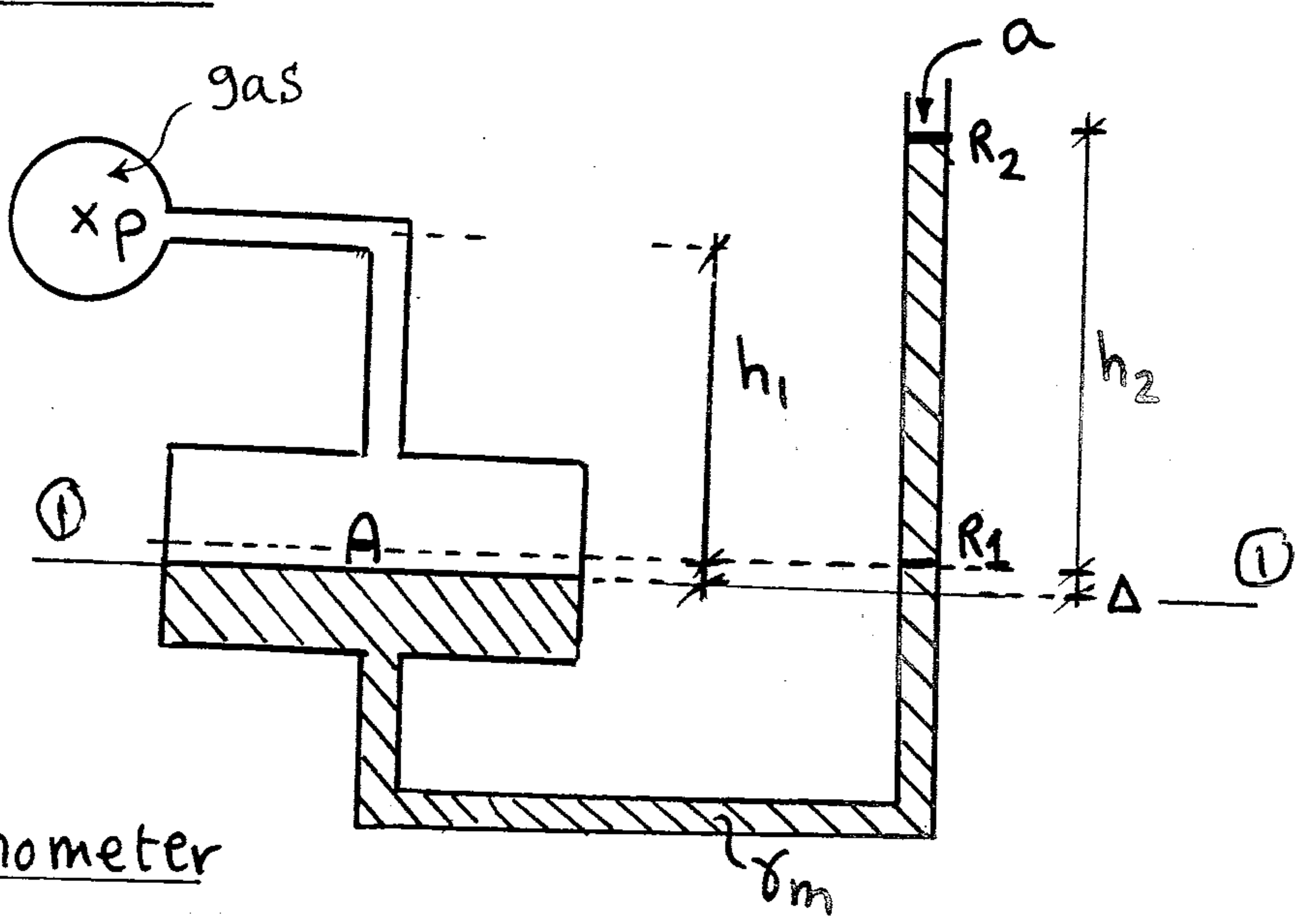

$$A \Delta = h_2 a$$

ii- Inclined tube manometer

$$A \Delta = L a$$

$$a = \frac{\pi d^2}{4}$$

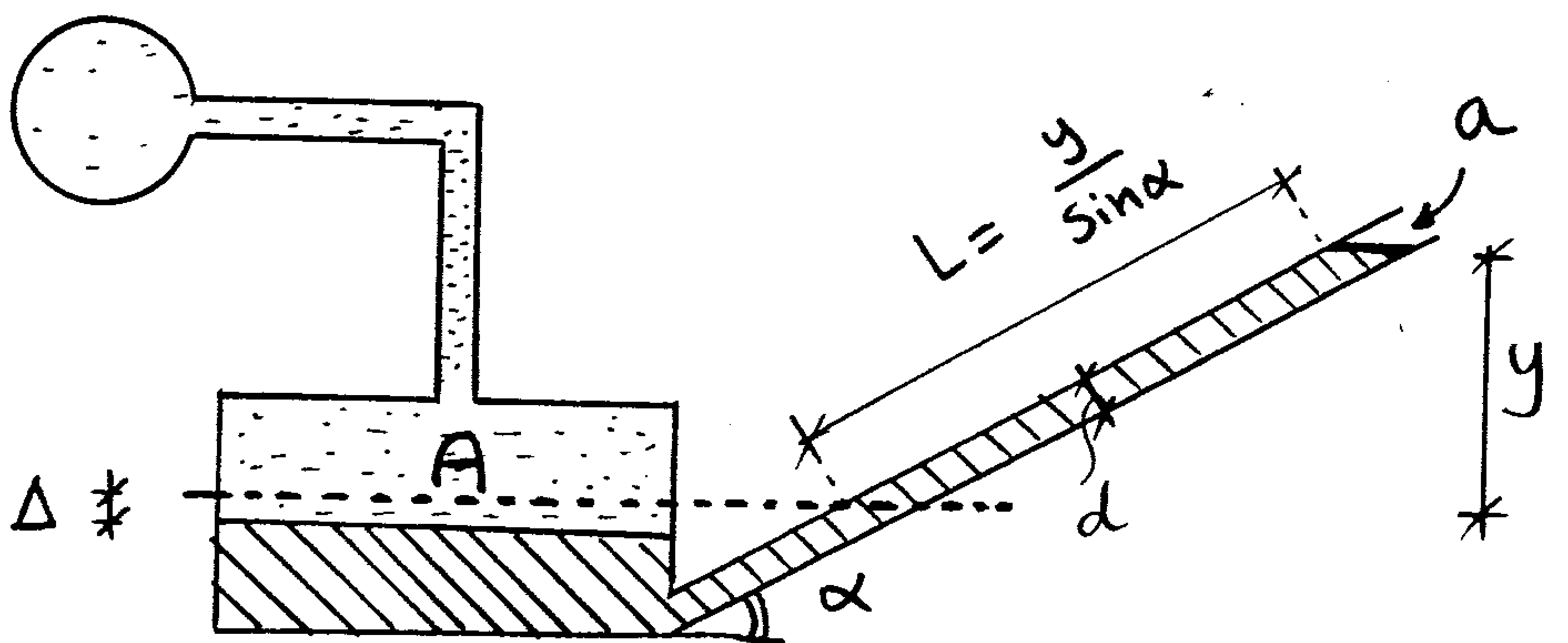

(7)

# Pascal's law

The intensity of Pressure at any point in a fluid at rest, is the same in all directions

Consider a triangular prism of very small size

$$\underline{\Sigma F_x = 0}$$

$$P_s \cdot ds \sin \theta = P_x \cdot dz$$

$$P_s \cdot ds \frac{dz}{ds} = P_x \cdot dz$$

$$\therefore \boxed{P_s = P_x}$$

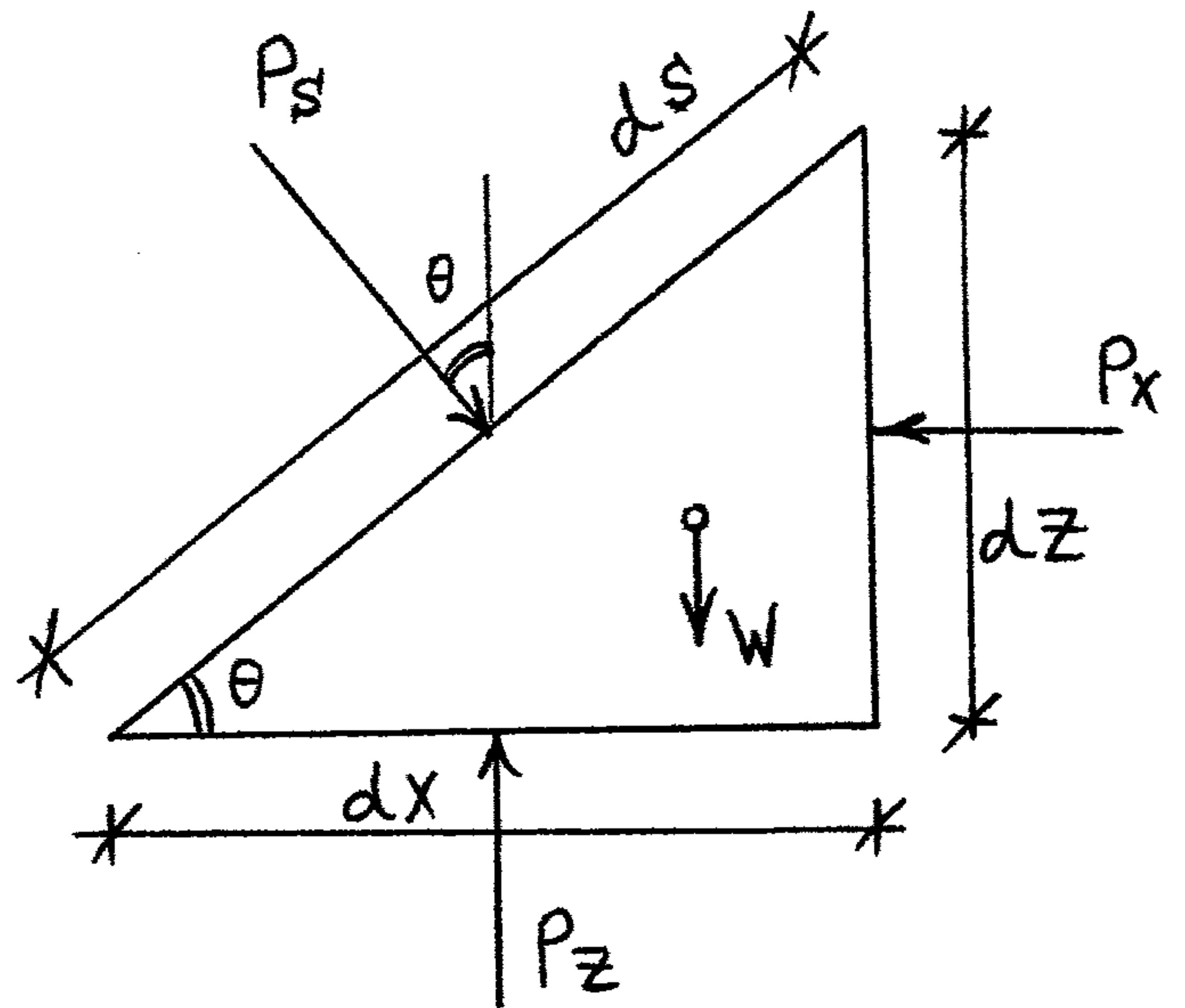

$$\underline{\Sigma F_z = 0}$$

$$P_s \cdot ds \cos \theta + W = P_z \cdot dx$$

$$P_s \cdot ds \cdot \frac{dx}{ds} + \frac{1}{2} dx dz \gamma = P_z \cdot dx$$

$$P_s + \frac{1}{2} dz \gamma = P_z$$

↳  $dz \approx 0$

$$\boxed{P_s = P_z}$$

$$\boxed{P_x = P_z = P_s}$$

Pascal's law

$$\sin \theta = \frac{dz}{ds}$$

$$\cos \theta = \frac{dx}{ds}$$

⑧

Intensity of Pressure means rate of change of

Pressure in a certain direction  $(\frac{dP}{dx}, \frac{\partial P}{\partial z})$

Variation of Pressure

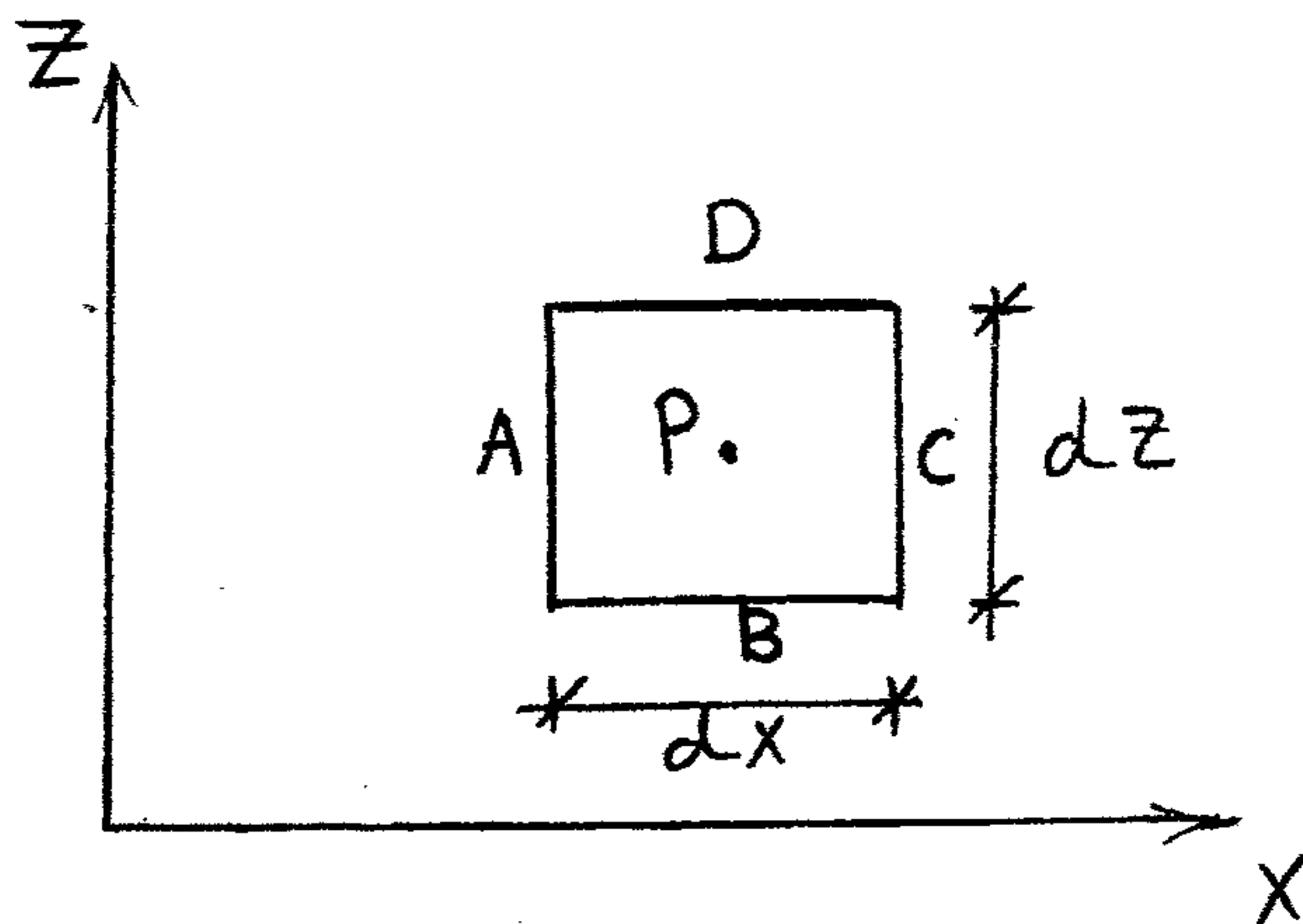
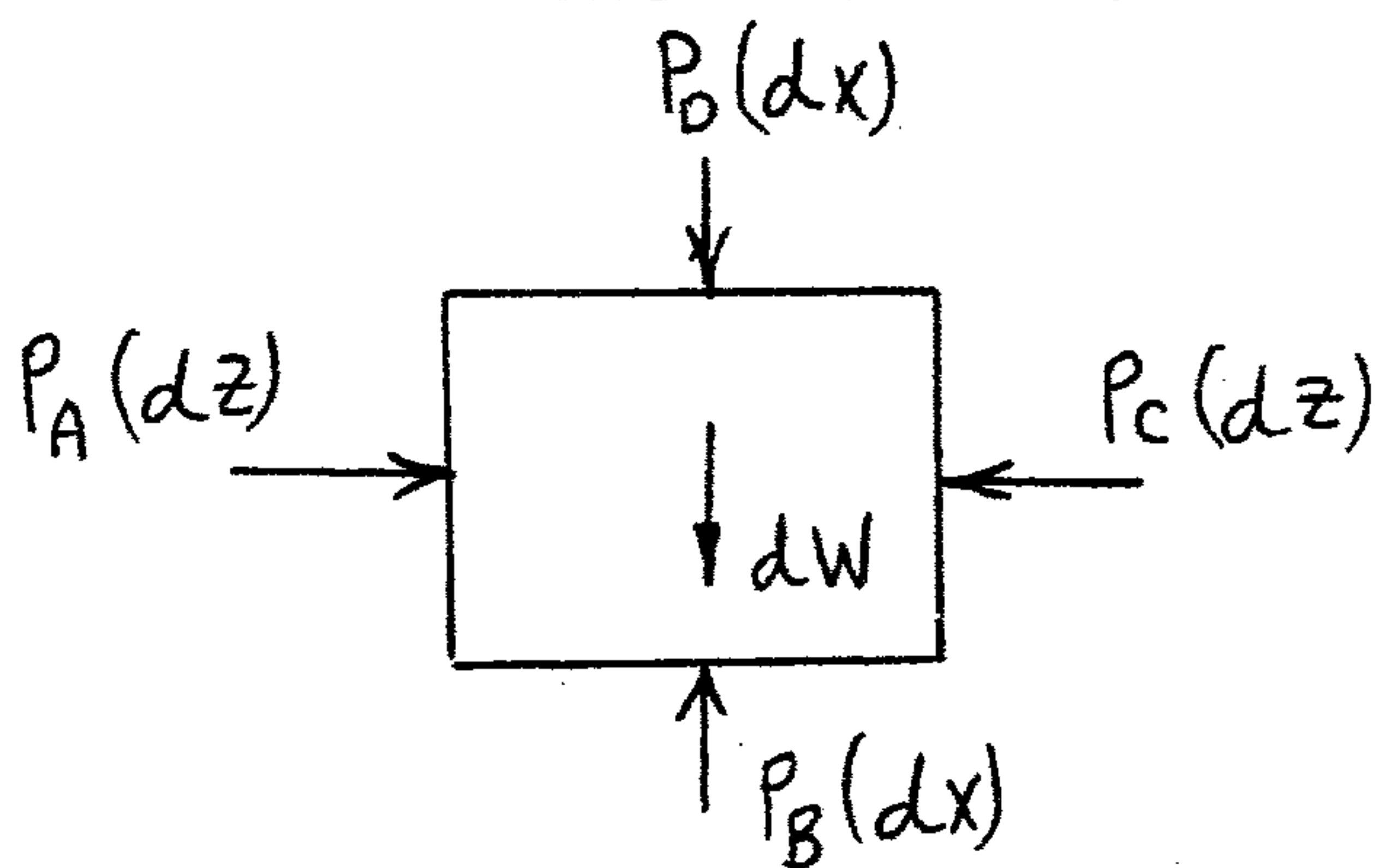

Consider a fluid element of size  $dx dz$  and unit length

Let the Static pressure at the Center of the element =  $P$

$$\Sigma F_x = P_A(dz) - P_C(dz) = 0 \quad \dots\dots (1)$$

$$\Sigma F_z = P_B(dx) - P_D(dx) - dW = 0 \quad \dots\dots (2)$$

$$\therefore P_A = P - \frac{\partial P}{\partial x} \cdot \frac{dx}{2} \quad , \quad P_C = P + \frac{\partial P}{\partial x} \cdot \frac{dx}{2}$$

$$P_B = P - \frac{\partial P}{\partial z} \cdot \frac{dz}{2} \quad P_D = P + \frac{\partial P}{\partial z} \cdot \frac{dz}{2}$$

$$dW = \gamma(dz)(dx)$$

From ①

$$\left(P - \frac{\partial P}{\partial x} \cdot \frac{dx}{2}\right)(dz) - \left(P + \frac{\partial P}{\partial x} \cdot \frac{dx}{2}\right)(dz) = 0$$

$$\frac{\partial P}{\partial x} = 0$$

$\therefore$  Pressure does not vary in horizontal direction

From ②

$$\left( P - \frac{\partial P}{\partial z} \cdot \frac{dz}{2} \right) dx - \left( P + \frac{\partial P}{\partial z} \cdot \frac{dz}{2} \right) dx - \gamma (dz) dx = 0 \quad \text{⑨}$$

$$-\frac{\partial P}{\partial z} dz - \gamma dz = 0$$

$$\frac{\partial P}{\partial z} = -\gamma$$

Pressure Varies in Vertical direction

For two points ①, ②

$$\int_{P_1}^{P_2} dP = -\gamma \int_{z_1}^{z_2} dz$$

$$\therefore P_2 - P_1 = -\gamma (z_2 - z_1) = -\gamma h$$

$$\therefore P_1 = P_2 + \gamma h$$

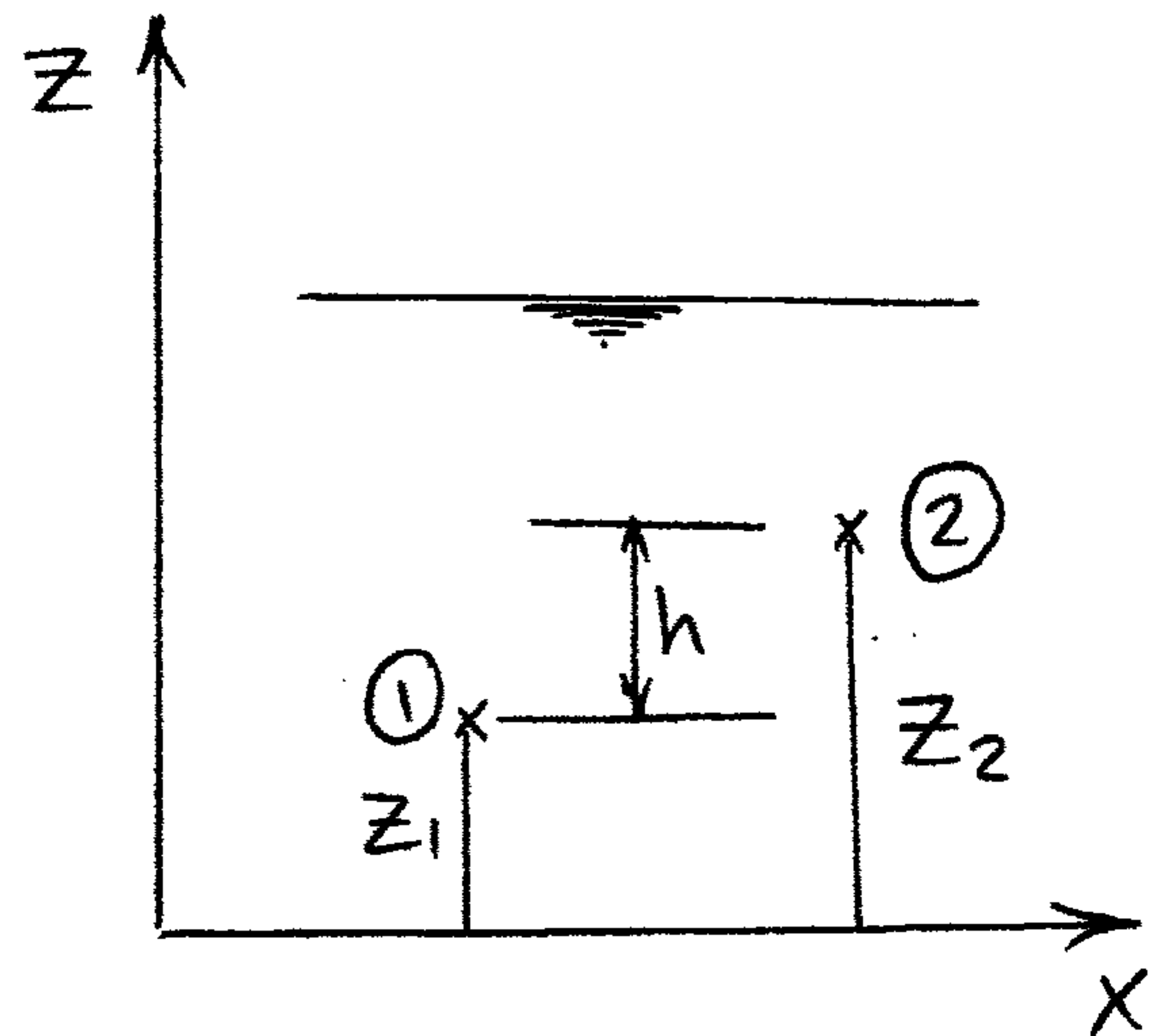

### Pascal's application

- 1- hydraulic press
- 2- hydraulic jack
- 3- hydraulic lift
- 4- hydraulic crane

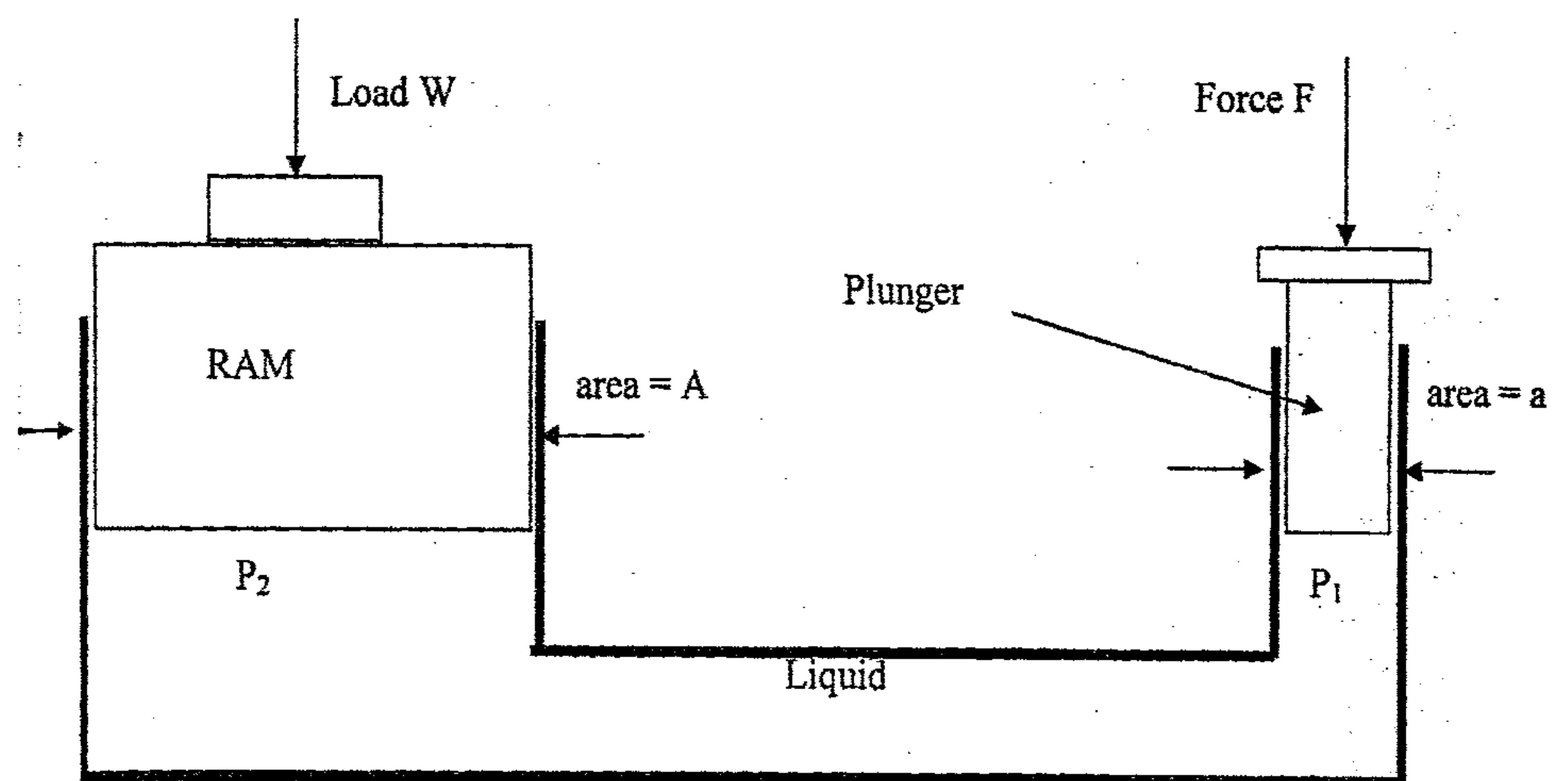

Working principle of hydraulic press

By applying a small force F on the plunger a larger load can be lifted by the ram



4

# Forces on Plane Surfaces

①

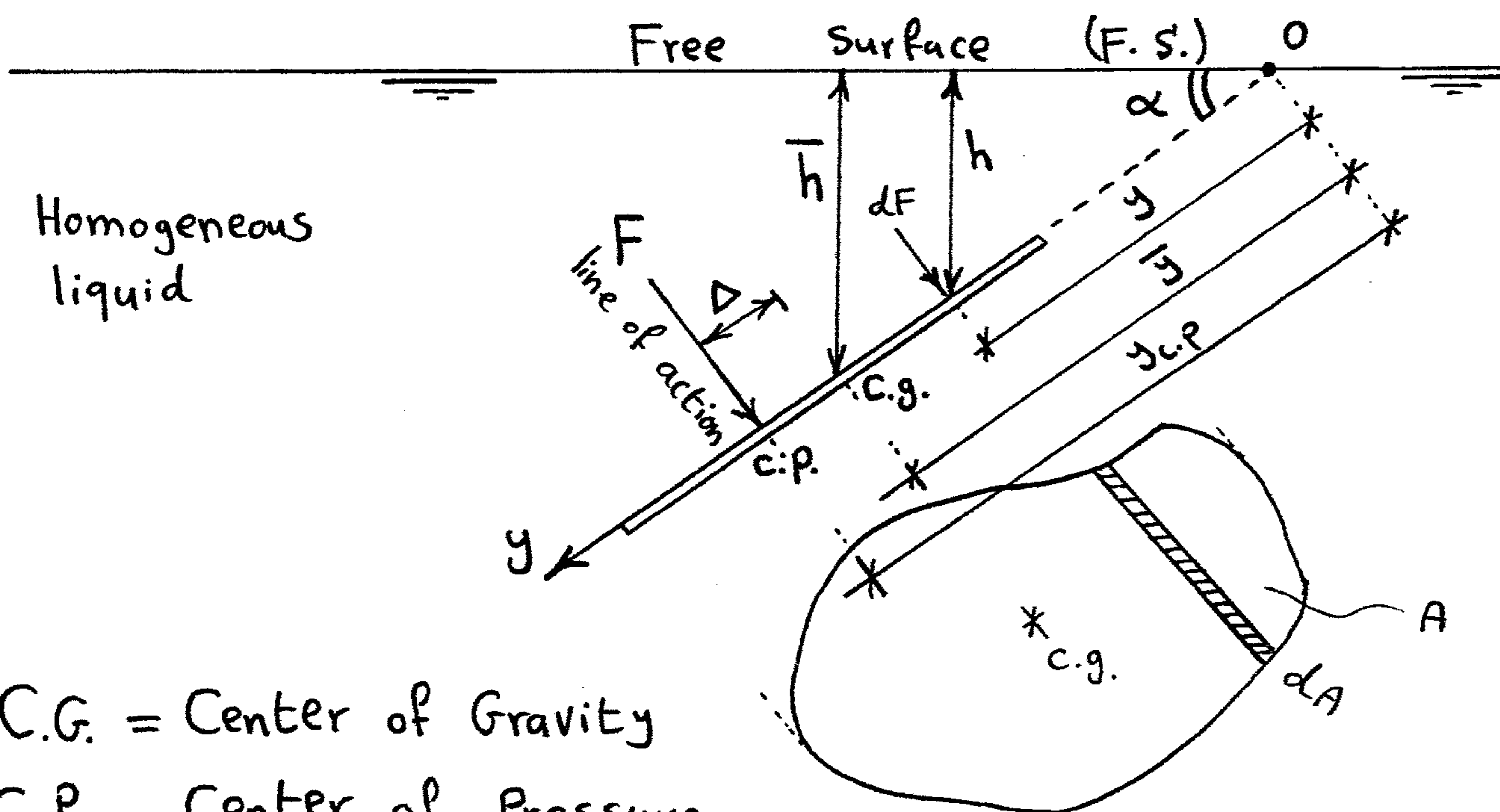

C.G. = Center of Gravity

C.P. = Center of Pressure

$A$  = Area of immersed surface ( $\perp$  to the page)

$\bar{h}$  = vertical distance from C.G. to the free surface (F.S.)

$\bar{y}$  = inclined distance from C.G. to the free surface (F.S.)

$\alpha$  = زاوية ميل السطح على الأفقى

To determine the resultant hydrostatic force

$$dF = P \cdot dA = \gamma h dA \quad \sin \alpha = \frac{h}{y}$$

$$= \gamma y \sin \alpha dA \quad \Rightarrow h = y \sin \alpha$$

$$\therefore \int dF = \gamma \sin \alpha \int y dA$$

$$\therefore \int y dA = A \bar{y} \quad (\text{First moment of Area about point } 0)$$

$$\therefore F = \gamma \sin \alpha A \bar{y}$$

$$\boxed{F = \gamma A \bar{h}}$$

$$\boxed{\bar{y} = \frac{\bar{h}}{\sin \alpha}}$$

To determine the line of action

(2)

The moment  $dM$  due to the force about  $O$  is

$$dM = dFy$$

$$= (\gamma y \sin \alpha dA) y$$

$$\int dM = \gamma \sin \alpha \int_0^{A_p} y^2 dA$$

$$\therefore \int dM = F \cdot y_{c.p}$$

$$\therefore \int_0^{A_p} y^2 dA = I_0 \quad (\text{second moment of Area about point } O)$$

$$\therefore F y_{c.p} = \gamma \sin \alpha I_0$$

$$\gamma \bar{y} \sin \alpha A y_{c.p} = \gamma \sin \alpha I_0$$

$$y_{c.p} = \frac{I_0}{A \bar{y}}$$

$$\therefore I_0 = I_{c.g} + A \bar{y}^2$$

$$y_{c.p} = \frac{I_{c.g} + A \bar{y}^2}{A \bar{y}}$$

$$y_{c.p} = \frac{I_{c.g}}{A \bar{y}} + \bar{y}$$

$\Delta$

$$\Delta = \frac{I_{c.g}}{A \bar{y}}$$

(F) Resultant مكانة تأثير الـ  $\Delta$  ←  
دائماً أسفل الـ  $O$  بمسافة  $\Delta$

# Properties of Area

## 1- Rectangle

$$A = bZ$$

$$I_{xx} = \frac{bZ^3}{12}$$

المختص \* الظاهر  
١٢

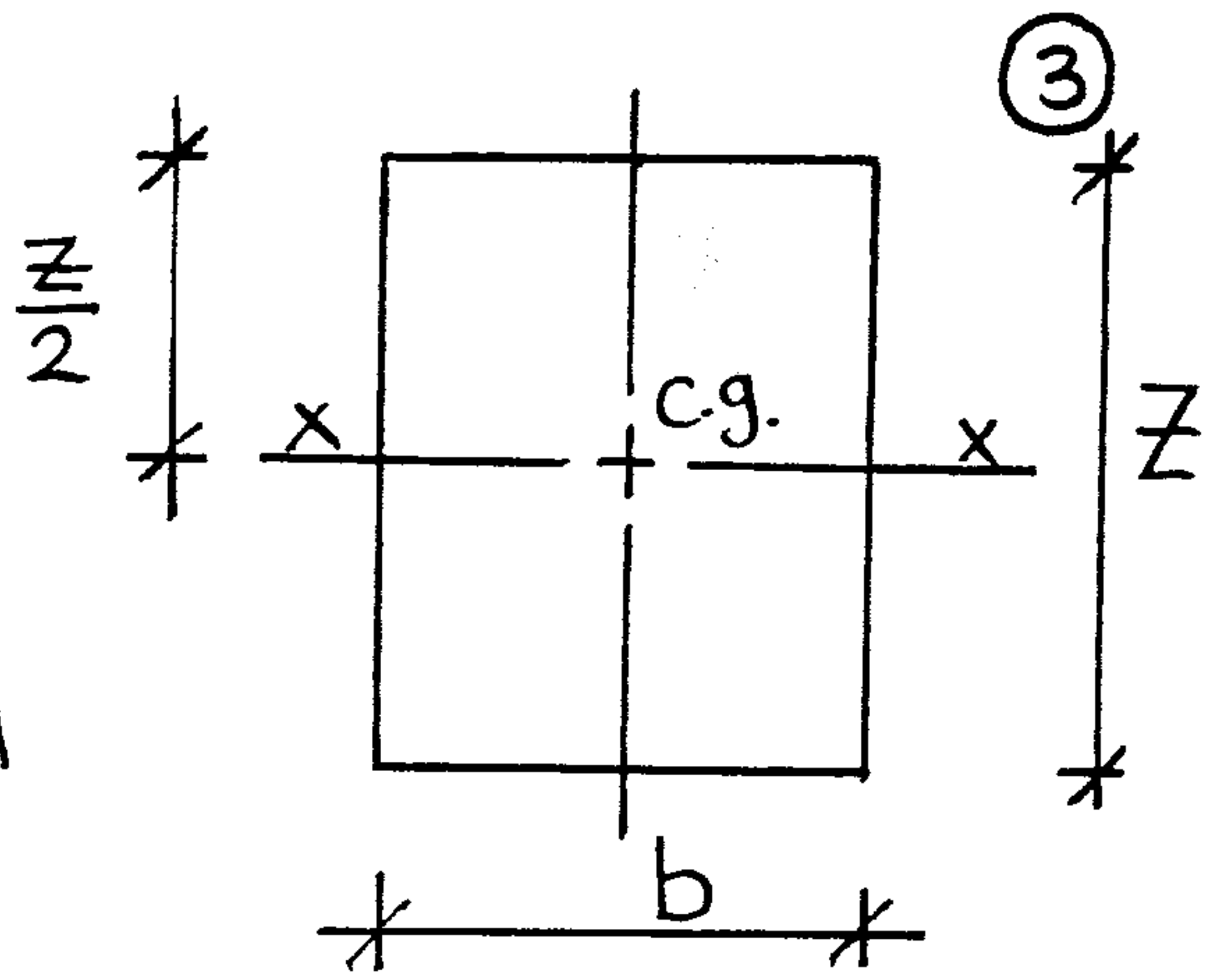

## 2- Triangle

$$A = \frac{1}{2} bZ$$

$$I_{xx} = \frac{bZ^3}{36}$$

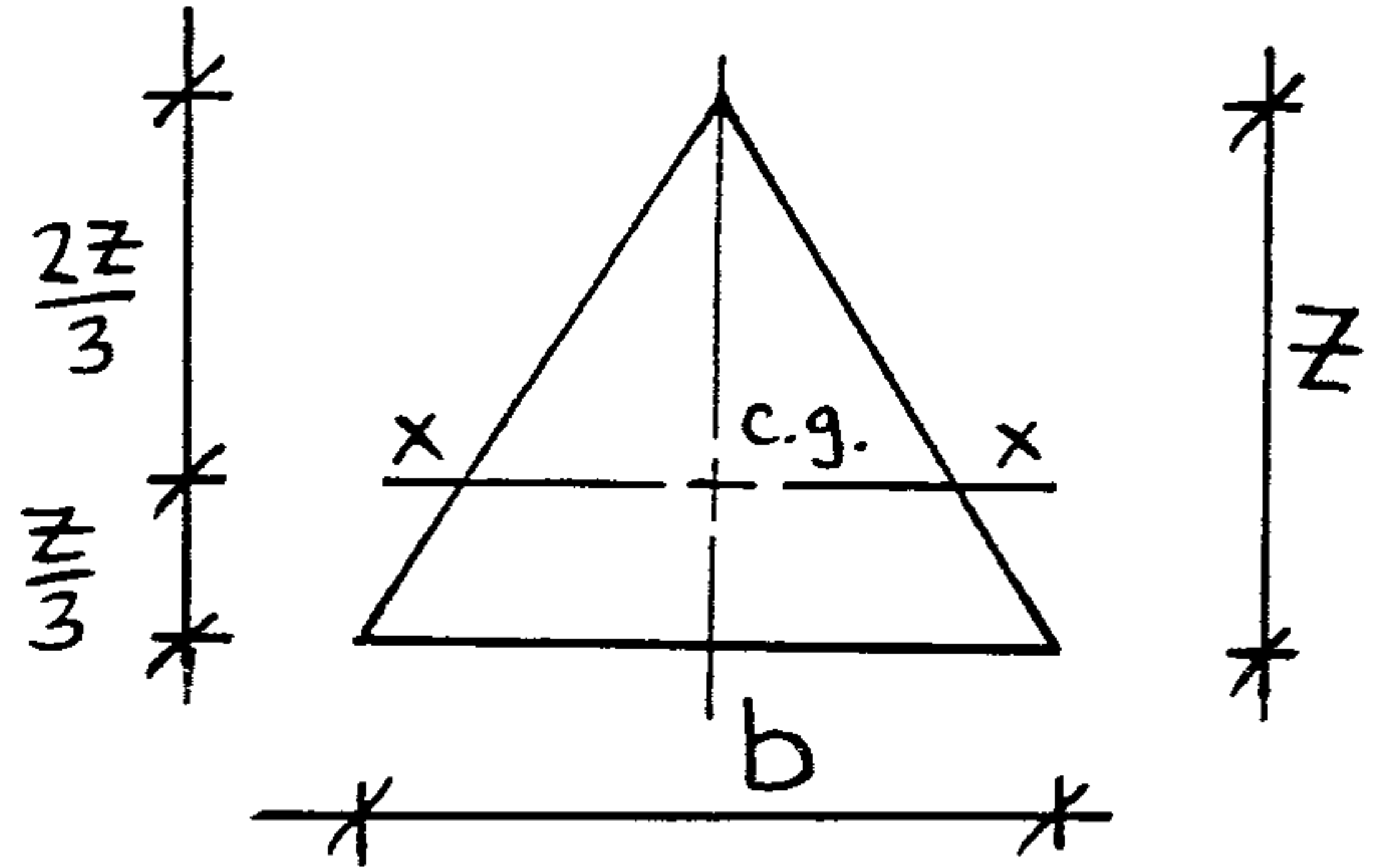

## 3- Circle

$$A = \frac{\pi d^2}{4}$$

$$I_{xx} = \frac{\pi d^4}{64}$$

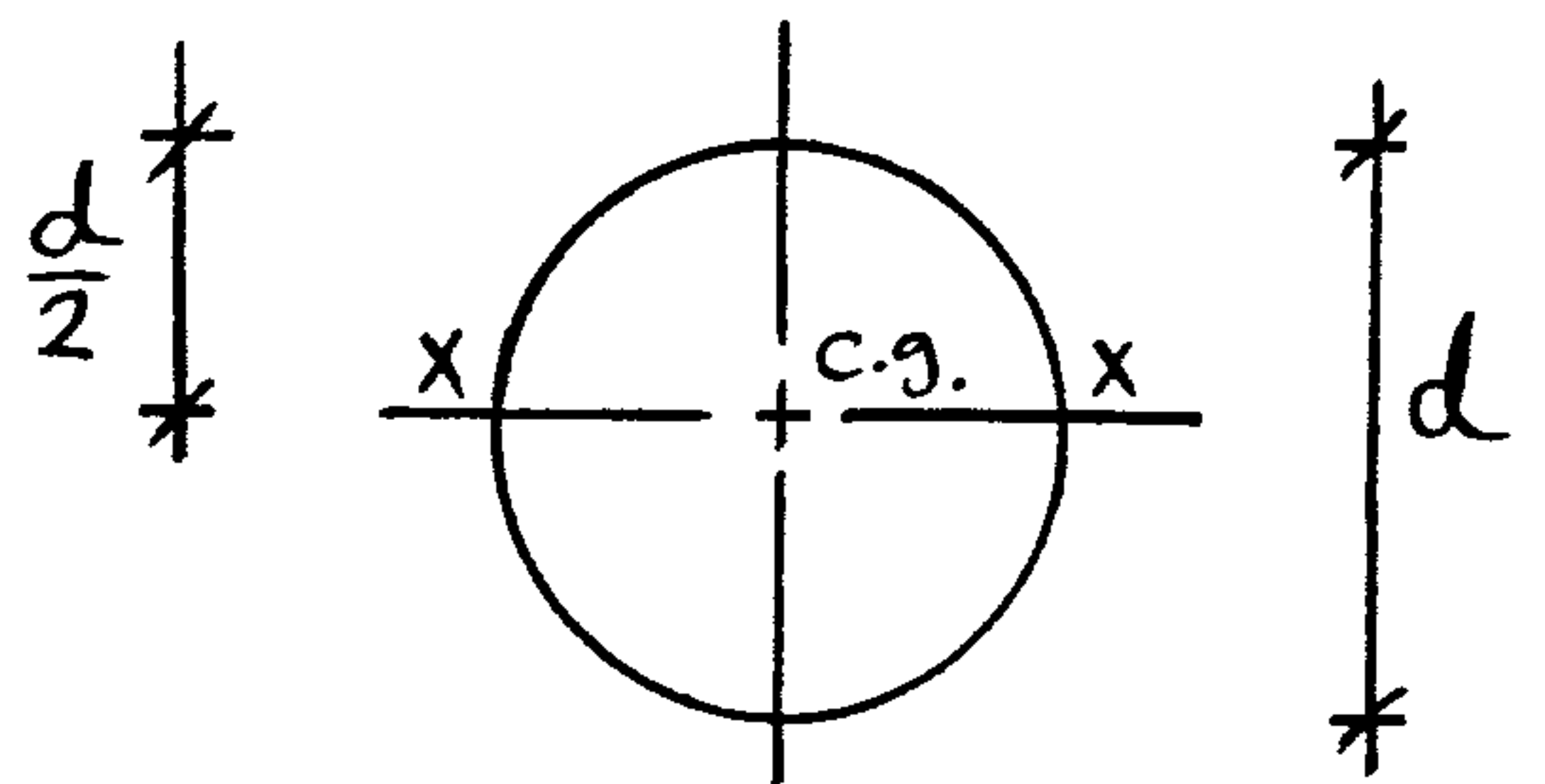

## 4- Semi circle

$$A = \frac{\pi d^2}{8}$$

$$I_{xx} = \frac{\pi d^4}{128} - \frac{d^4}{18\pi} = 0.11 r^4$$

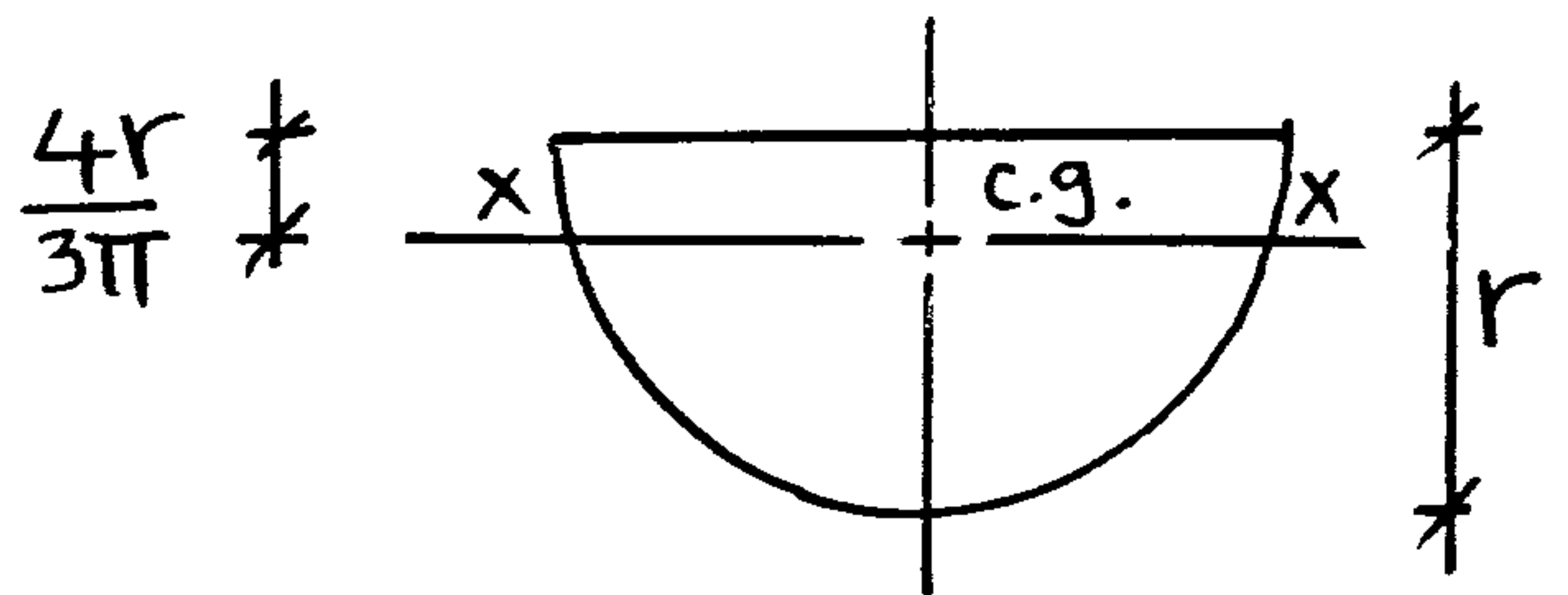

e.g. Calculate

①  $A = \frac{1}{2} bZ$

②  $I_{xx} = \frac{bZ^3}{36}$

③  $\bar{h} = \checkmark$

④  $\bar{y} = \frac{\bar{h}}{\sin \alpha}$

دائماً التكعيب هو البعد المرئي (Z)

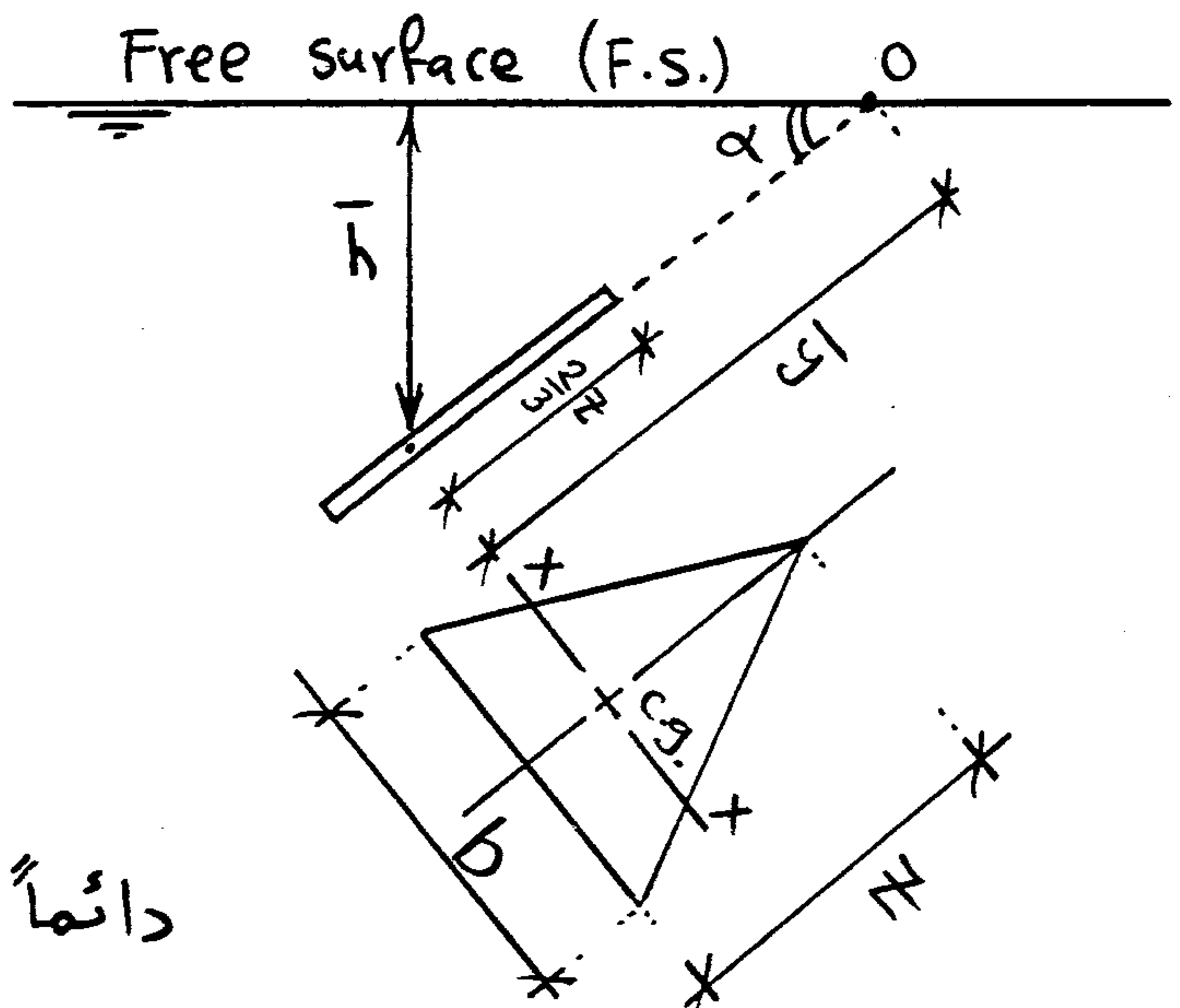

Special Cases

1-  $\alpha = 0$

$\bar{y} = h / \sin \alpha = \infty$

$\Delta = \frac{I_{c.g.}}{A \bar{y}} = \frac{I_{c.g.}}{\infty} = 0$

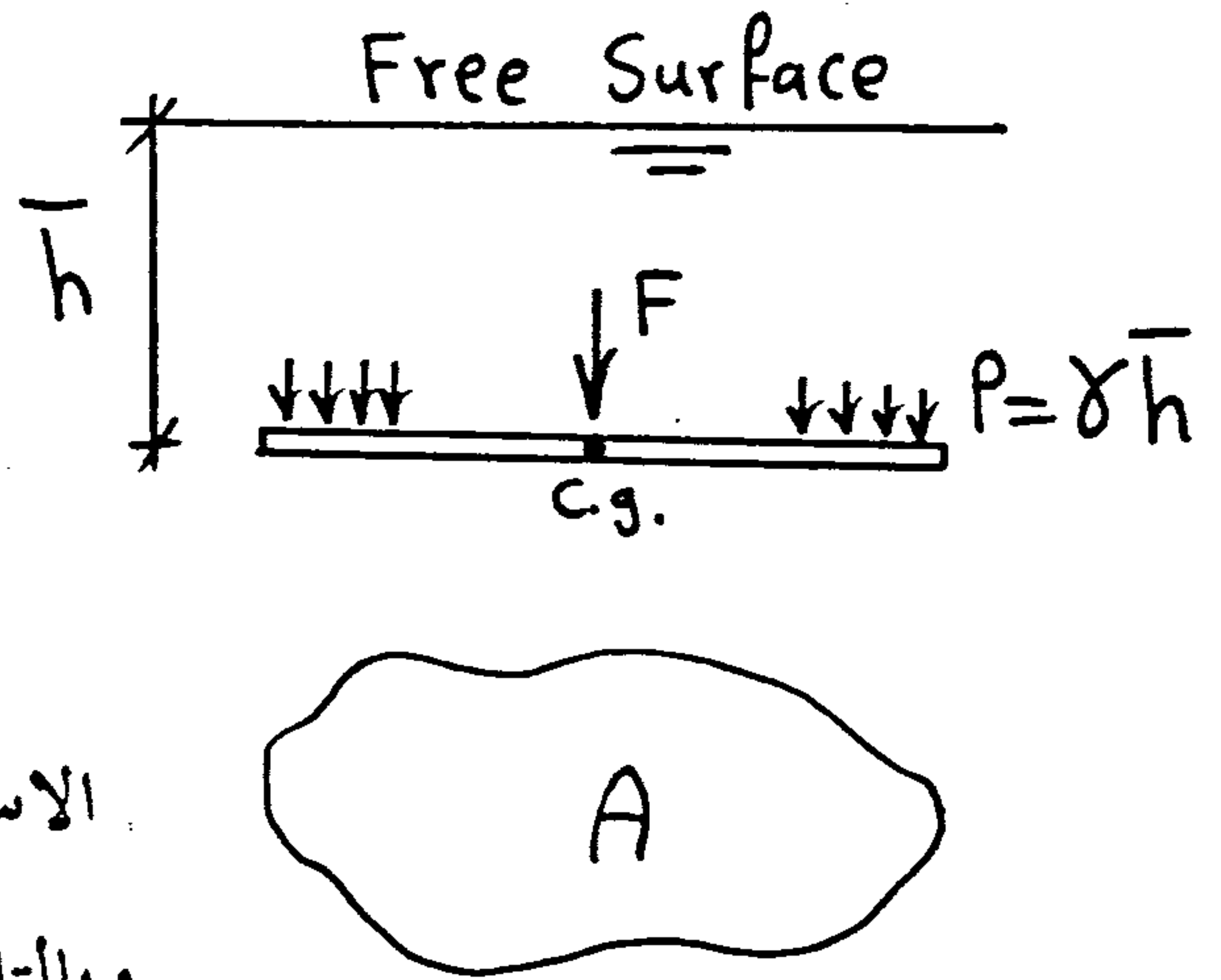

الاسطح المستوية الأفقية يكون عليها ضغط منتظم  
وبالتالي تؤثر القوة F في ال C.g. لهذا السطح

2-  $\alpha = 90^\circ$

$\bar{y} = h$

$\Delta = \frac{I_{c.g.}}{A h}$

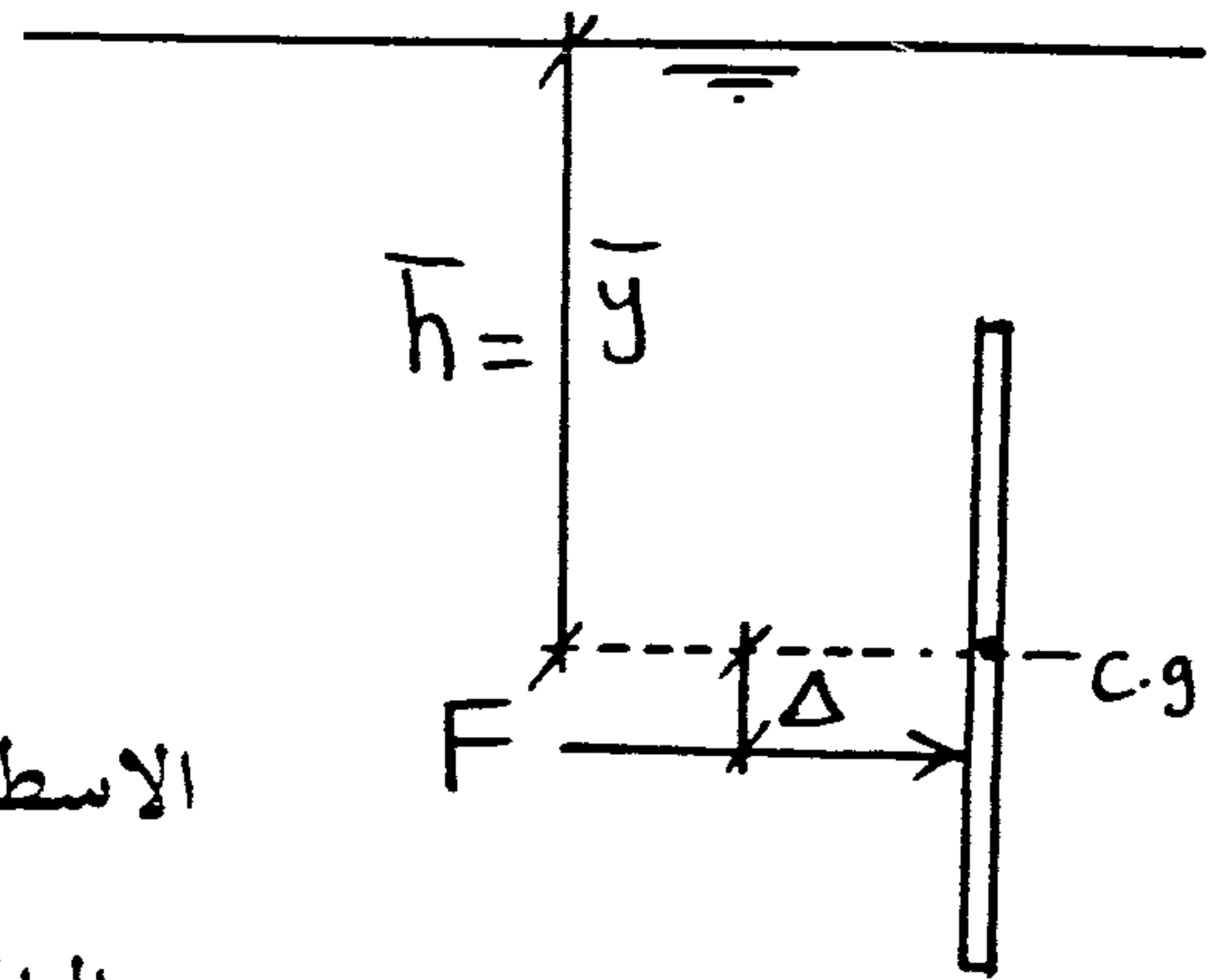

الاسطح الرأسية أو المائلة يكون عليها ضغط غير منتظم  
وبالتالي تؤثر القوة F أسفل ال C.g. بمسافة \Delta

3- Gas

ضغط الغاز موزع بانتظام على جدران الخزان  
وبالتالي تؤثر القوة F في ال C.g. للبوابة

$F = P \cdot A_{gate}$

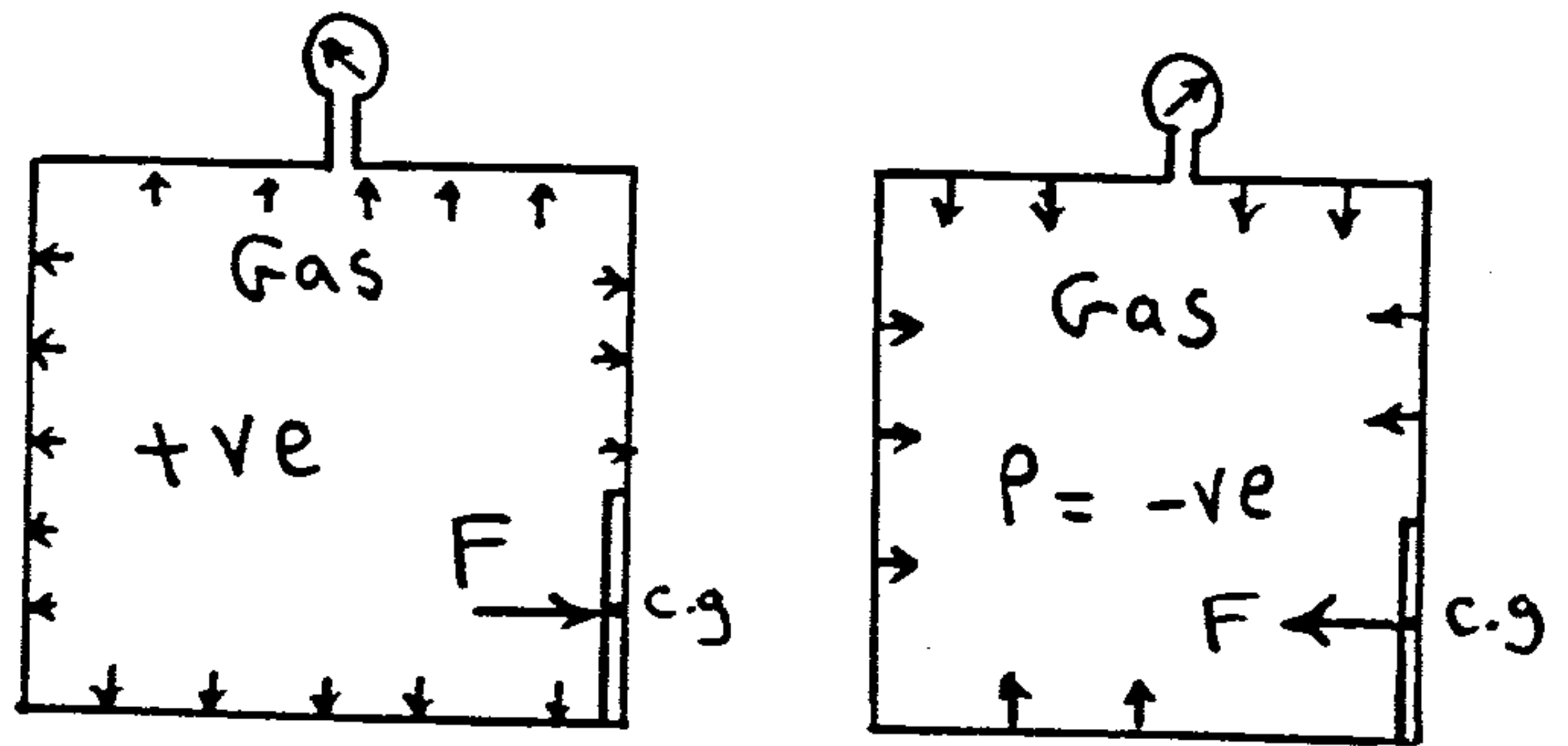

Pressure prism

منشور الضغط

تؤثر القوة F في مركز ثقل المنشور أي في ثلث الارتفاع من القاعدة  
أو (أسفل مركز الثقل في حالة المستطيلات بمسافة  $\Delta = \frac{h}{6}$ )

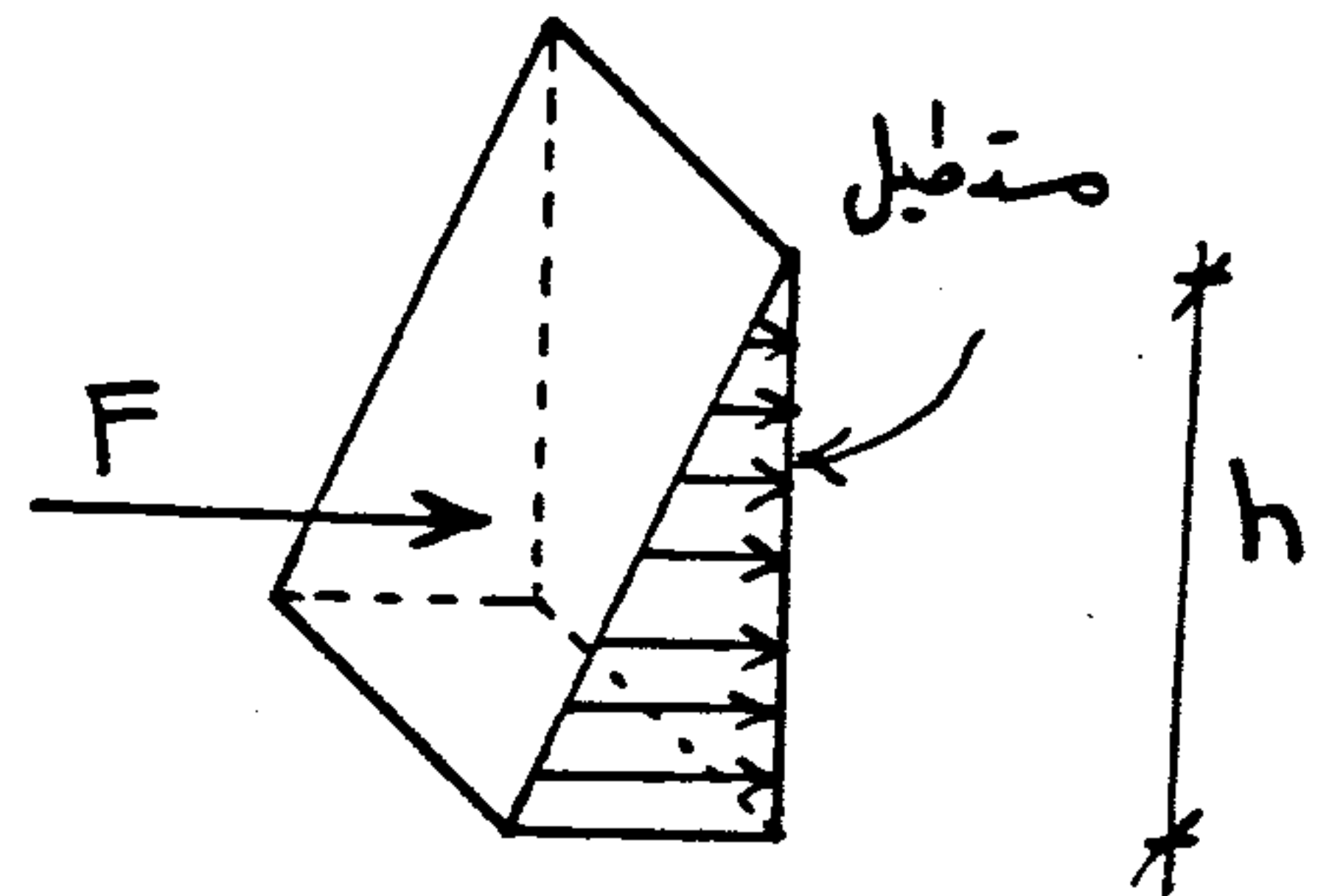

تؤثر القوة F في مركز ثقل الهرم أو أسفل مركز ثقل الثلث بمسافة \Delta

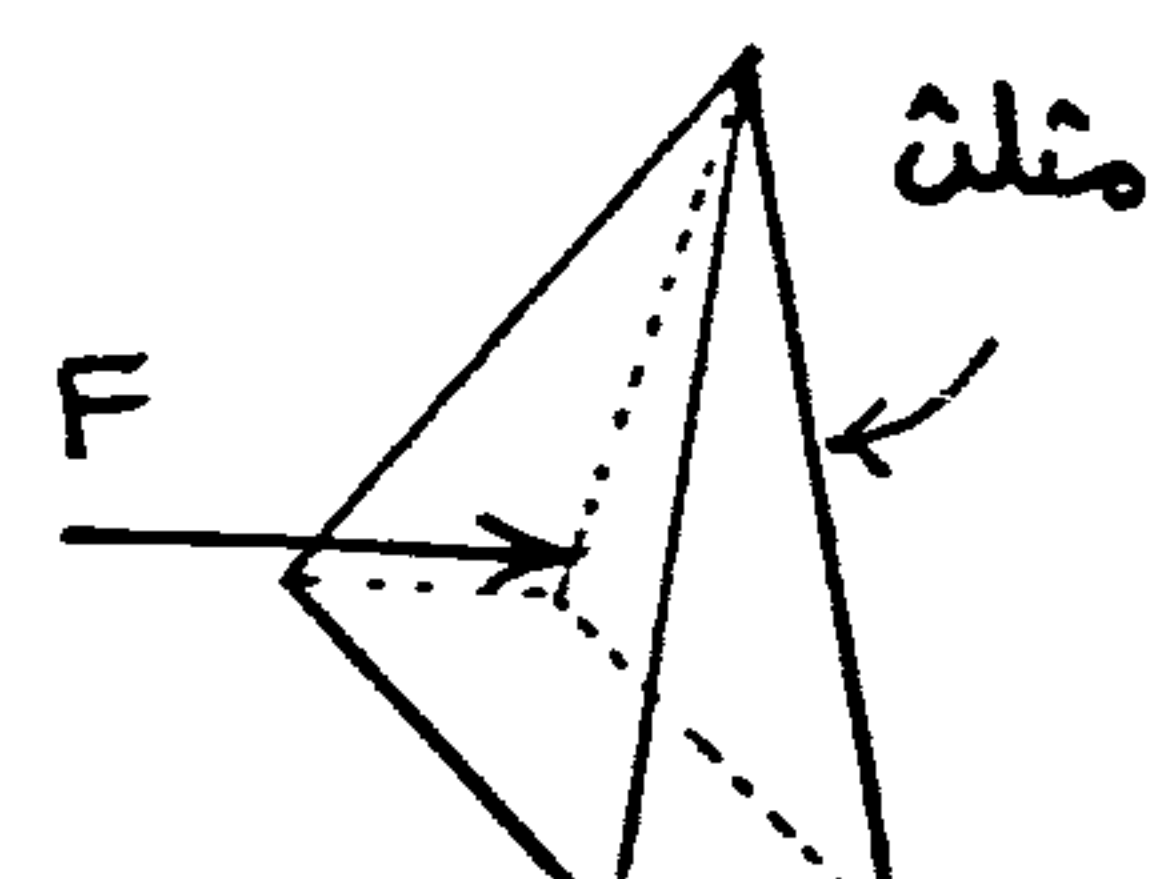

# 1- The Equation (for any surface)

(5)

$$F = \gamma A \bar{h}$$

$$\Delta = \frac{I_{c.g.}}{A \bar{y}}$$

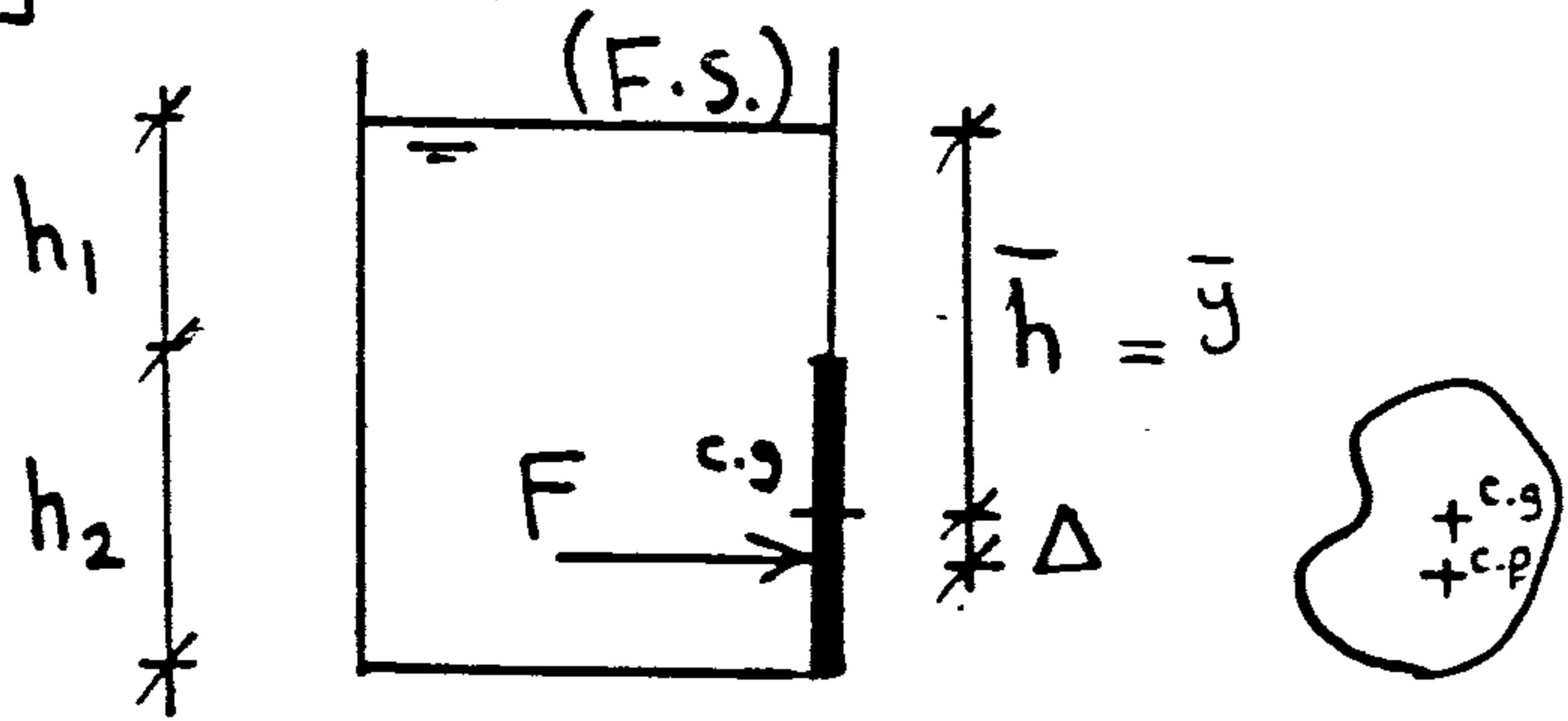

## Closed tank with 2 fluids

∴ البوابة كلها مغمورة في السائل فإن أى ضغط فوق السائل  $\gamma_2$  سوف يؤثر بانتظام على البوابة

أى يؤثر بقوة فى ال C.g. للبوابة

$$F_0 = P.A$$

$$F_1 = \gamma_1 h_1 A$$

$$F_2 = \gamma_2 A \bar{h}_2$$

$$F_{total} = F_0 + F_1 + F_2$$

$$\Delta_2 = \frac{I_{c.g.}}{A \bar{y}_2}$$

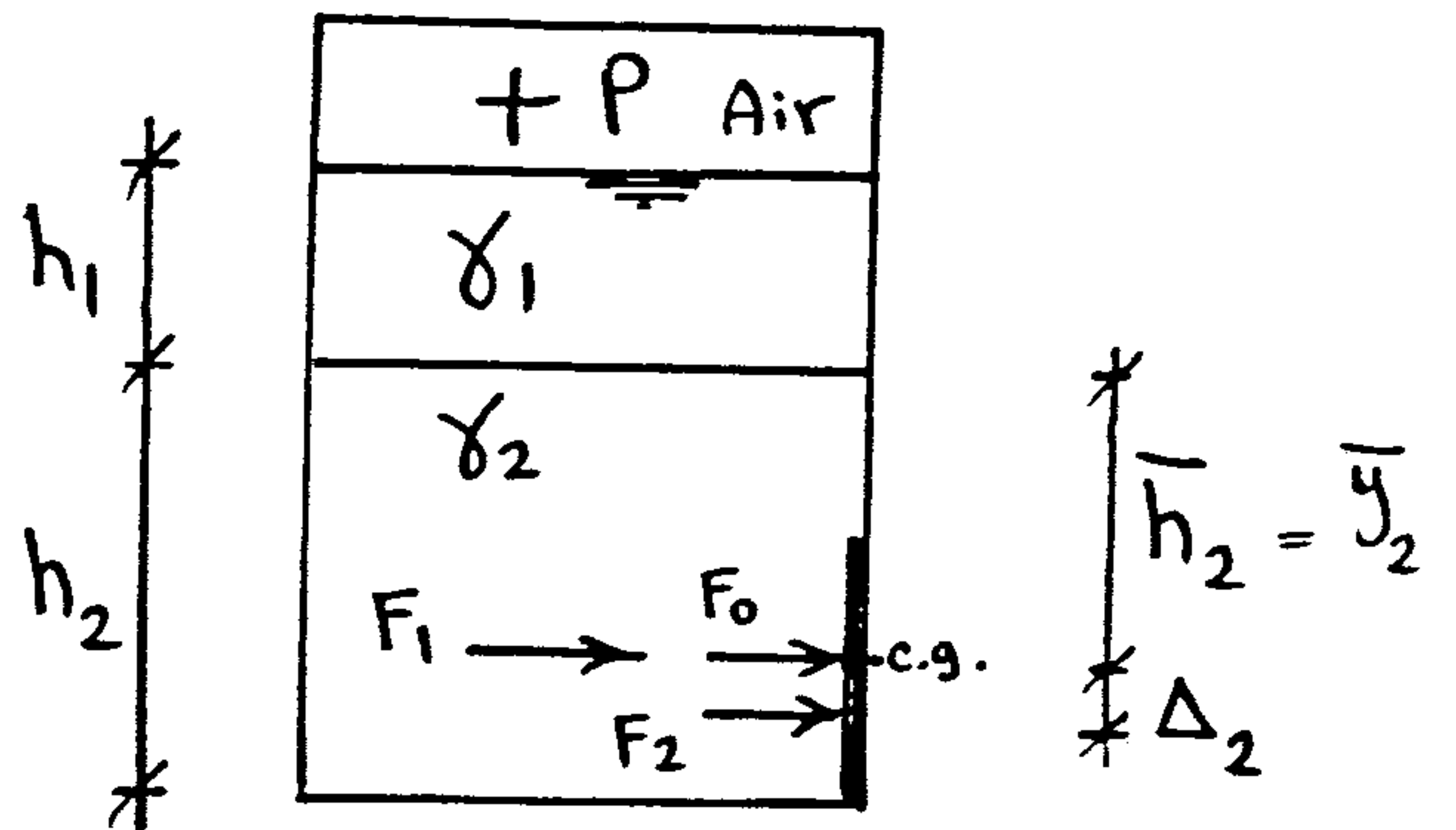

لايجاد مكان المحصلة  $F_{total}$  نأخذ العزم حول إحدى القوى

$$F_2 \Delta_2 = F_{total} \bar{z} \Rightarrow \text{get } \bar{z} \quad \text{عزم القوى حول نقطة} = \text{عزم المحصلة حول نفس النقطة}$$

## Inclined surface with 2 fluids (closed tank)

$$F_1 = (\gamma_1 h_1 + P) A$$

$$F_2 = \gamma_2 A \bar{h}_2$$

$$\bar{y}_2 = \frac{\bar{h}_2}{\sin \alpha}$$

$$\Delta_2 = \frac{I_{c.g.}}{A \bar{y}_2}$$

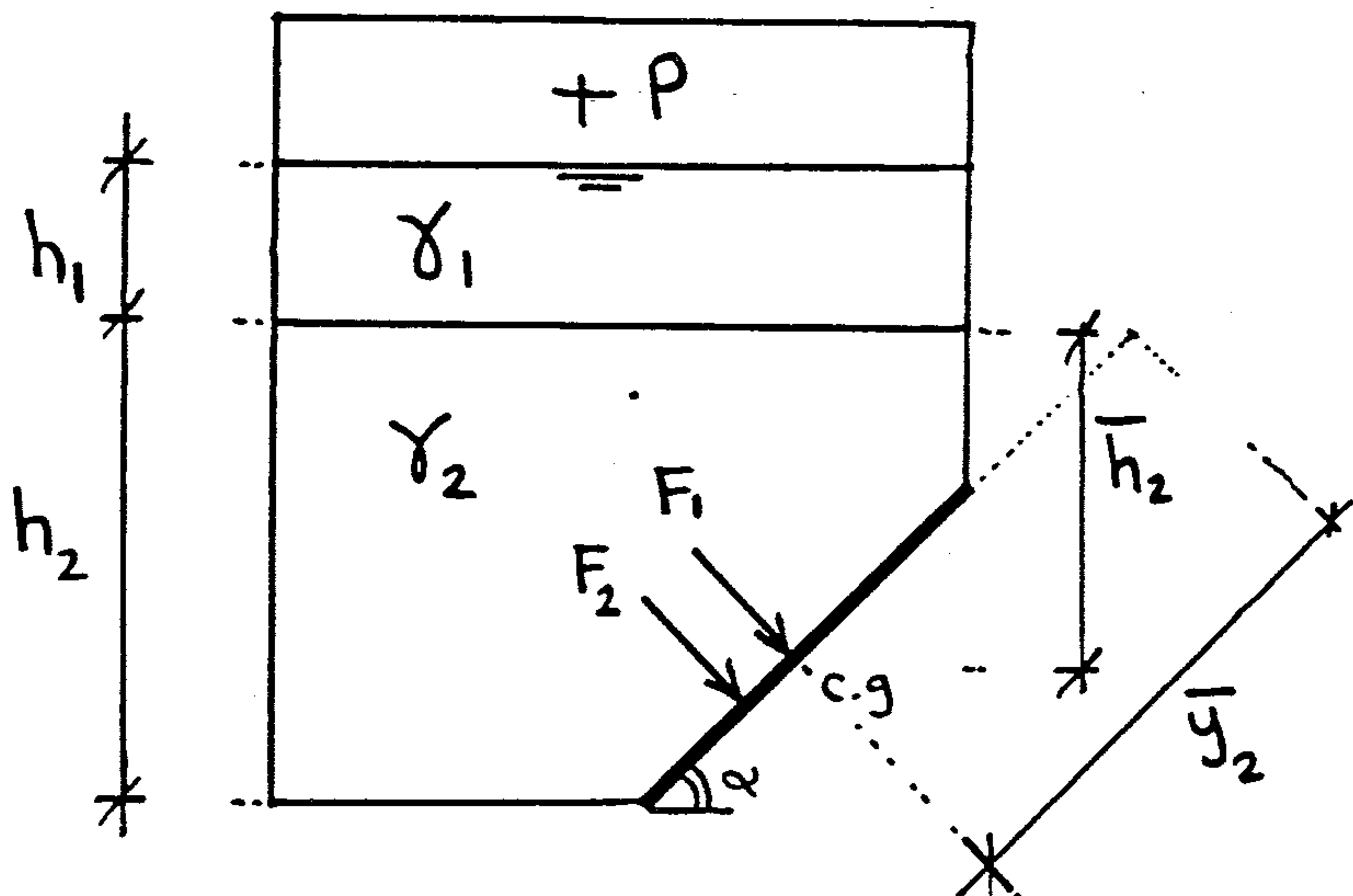

# Special Case

⑥

## Gate subjected to 2 fluids

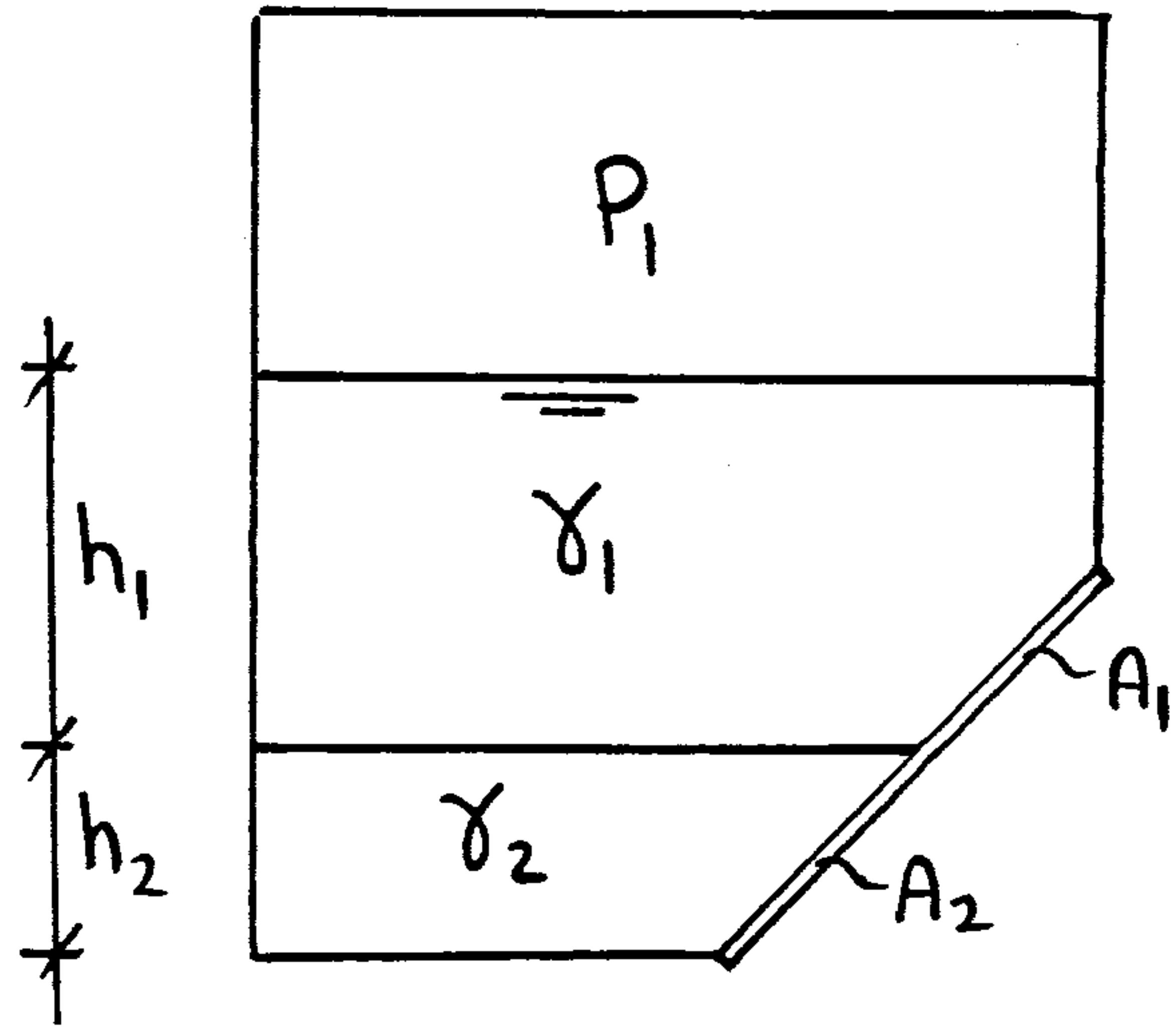
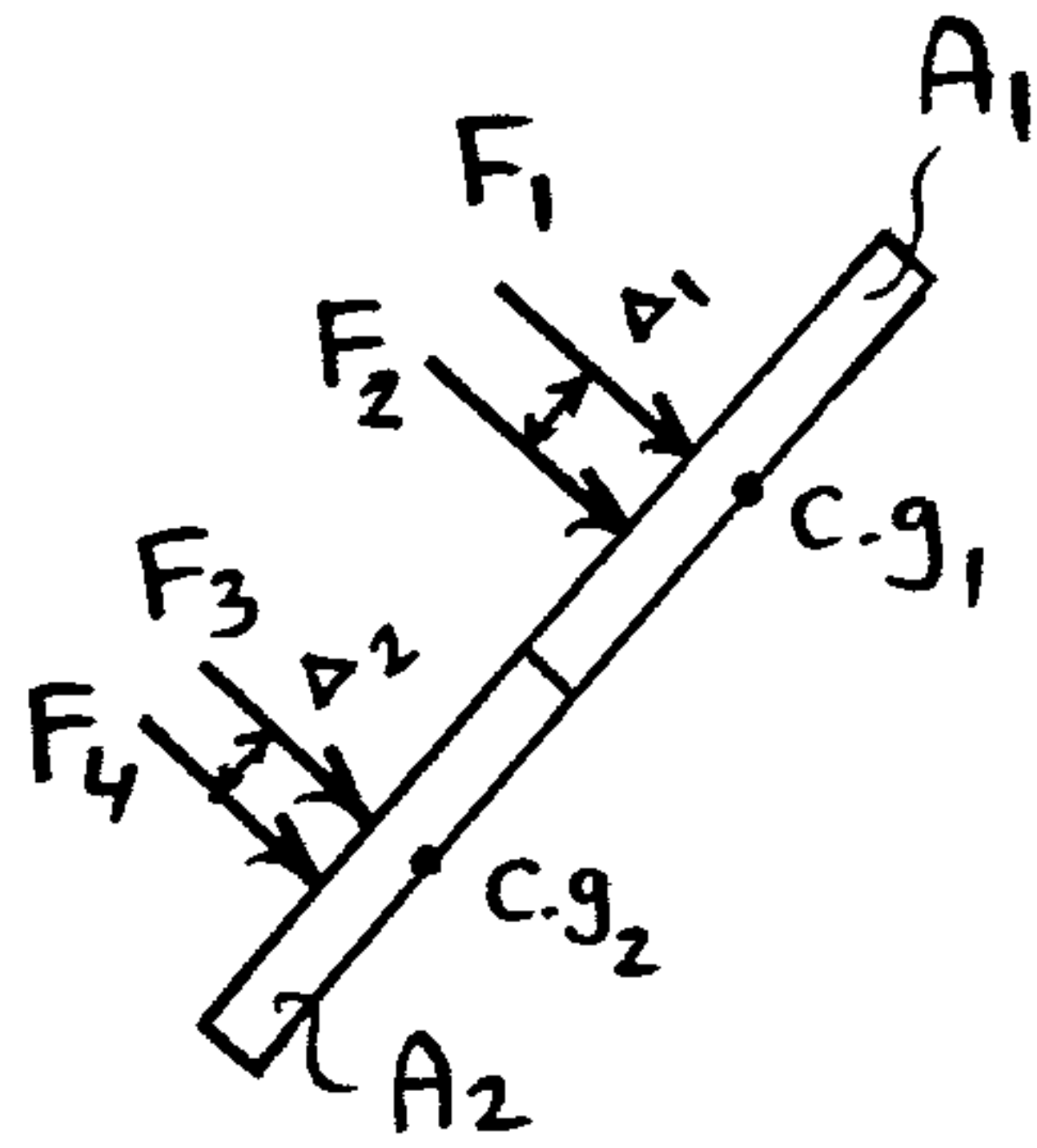

$$F_1 = P_1 A_1$$

$$F_2 = \gamma_1 A_1 \bar{h}_1$$

$$\Delta = \frac{I_{c.g.1}}{A_1 \bar{y}_1}$$

$$\bar{y}_1 = \frac{\bar{h}_1}{\sin \alpha}$$

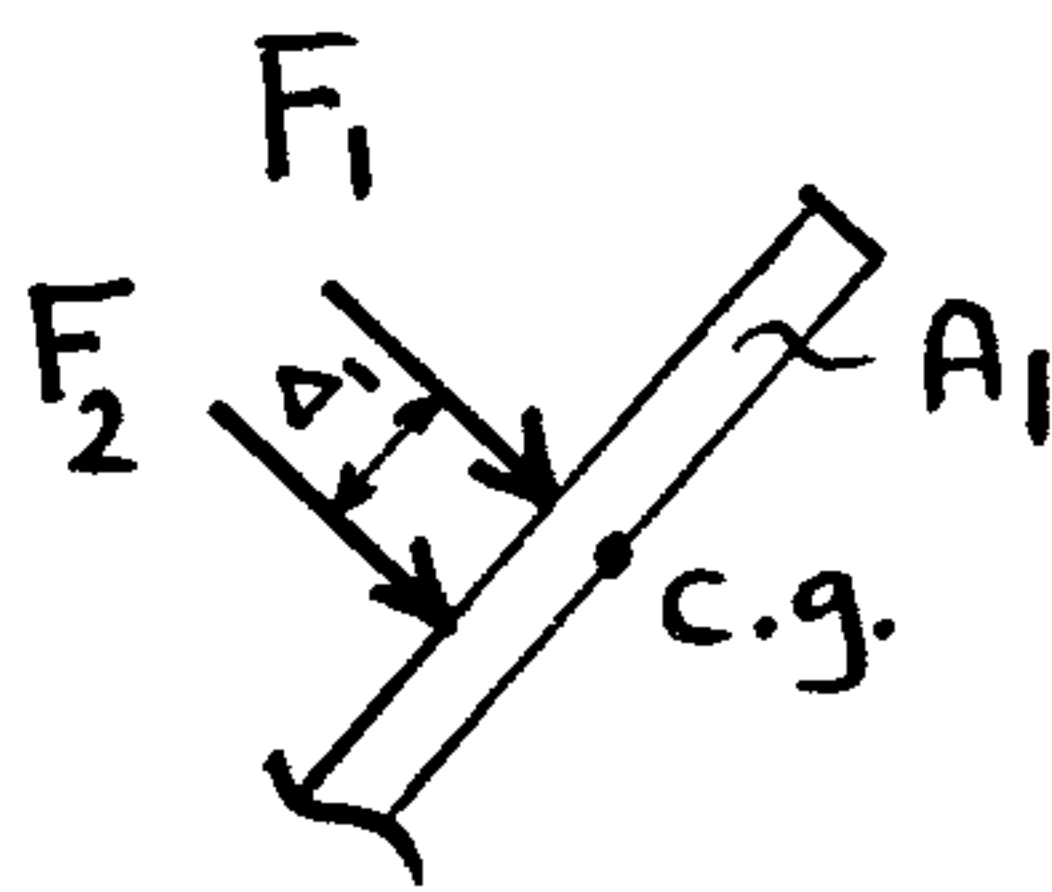

نقسم المائلة إلى جزئين

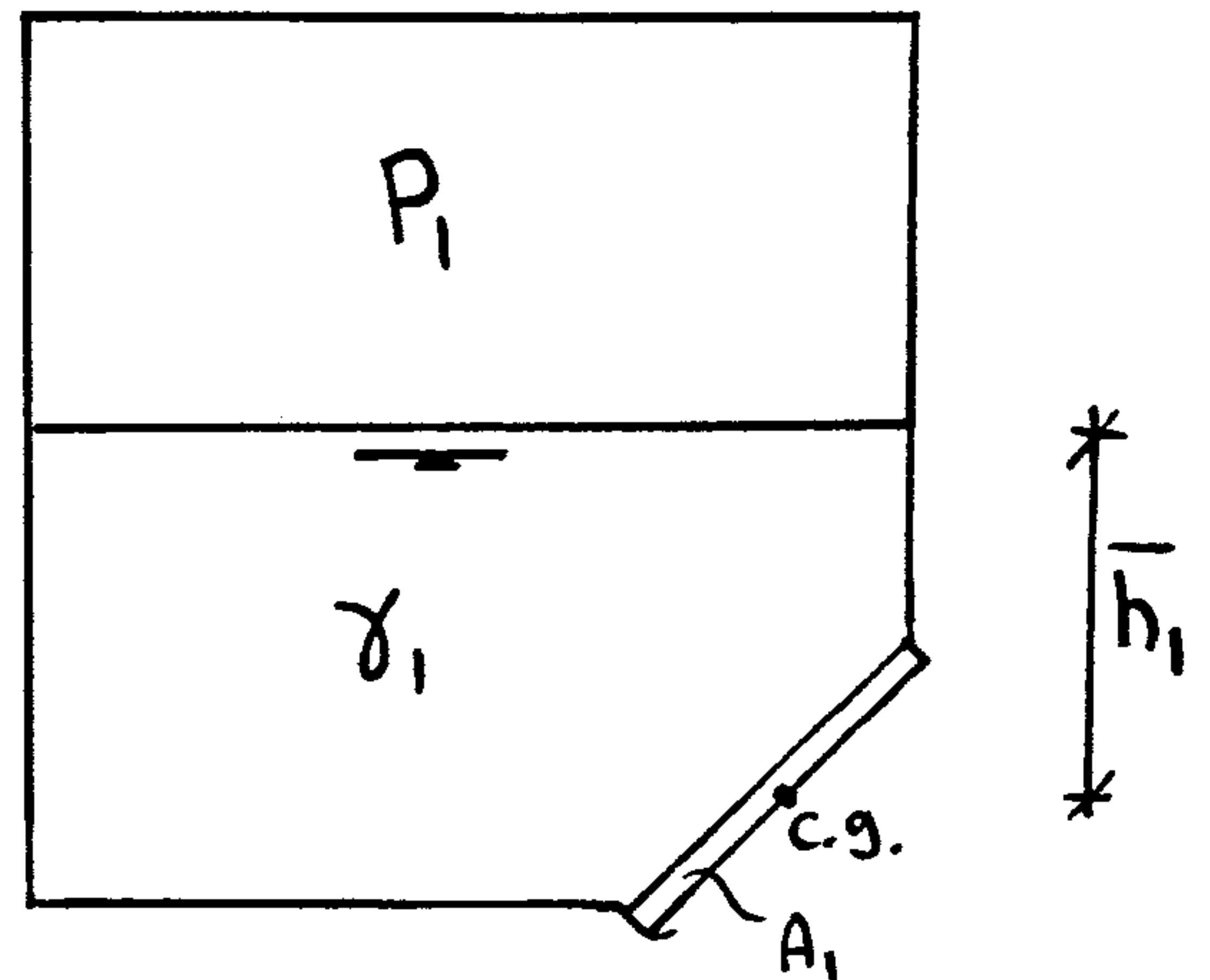

$$P_2 = P_1 + \gamma h_1$$

$$F_3 = P_2 A_2$$

$$F_4 = \gamma_2 A_2 \bar{h}_2$$

$$\Delta = \frac{I_{c.g.2}}{A_2 \bar{y}_2}$$

$$\bar{y}_2 = \frac{\bar{h}_2}{\sin \alpha}$$

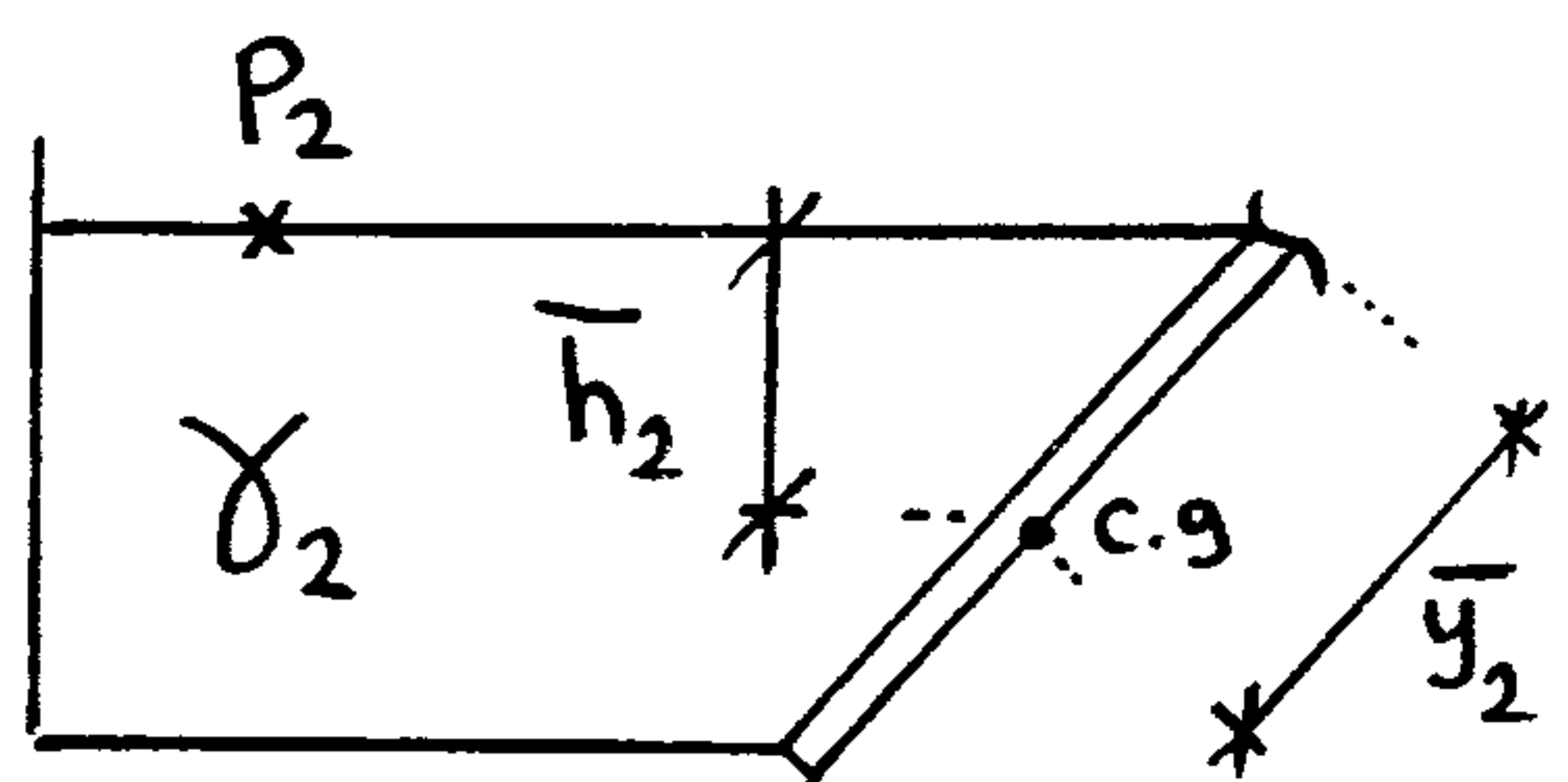
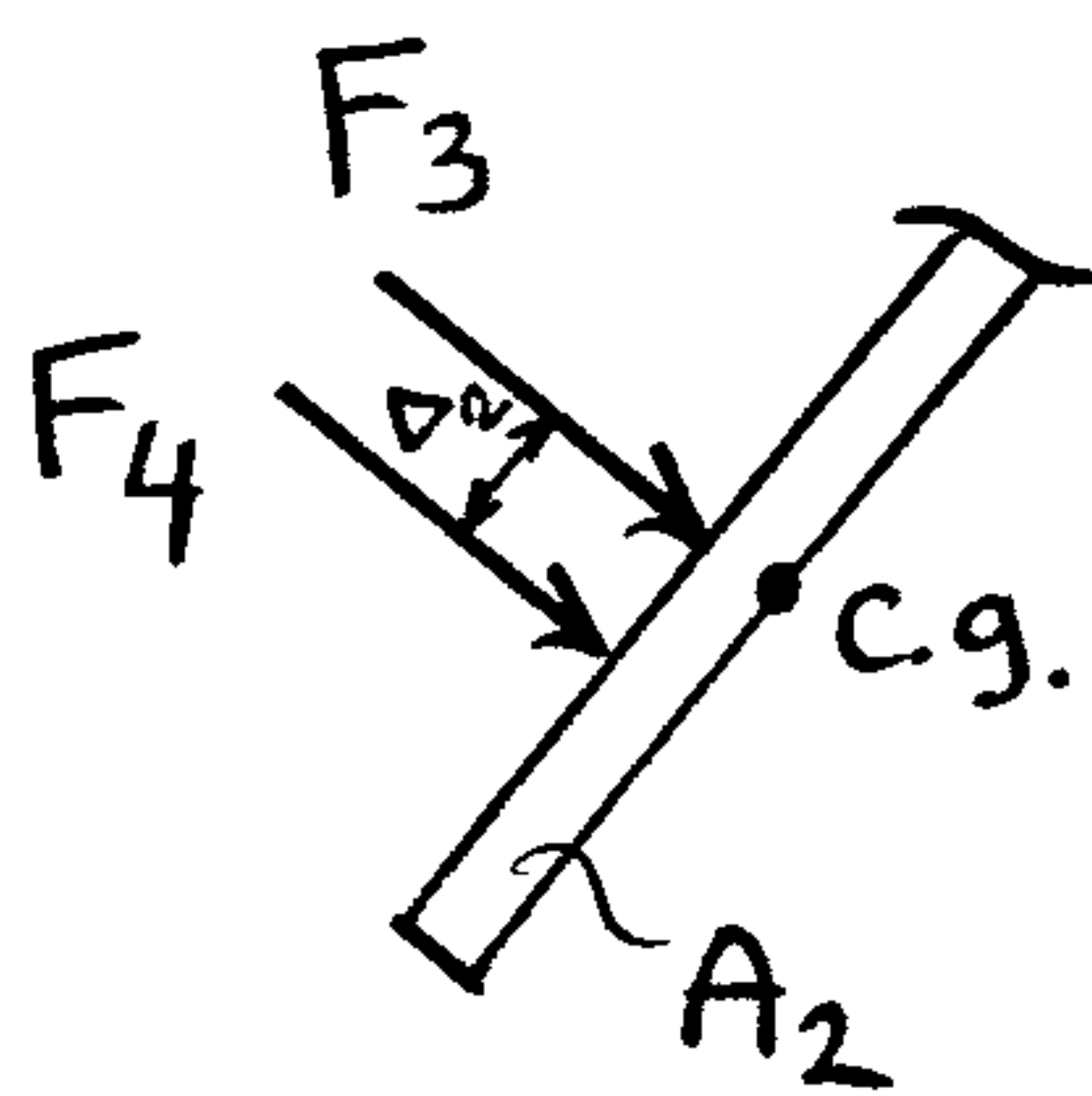

2- Pressure distribution  
(For rectangular surfaces only)

(7)

طريقة توزيع الضغط

$$F = \frac{1}{2} \gamma h h b$$

$$= \frac{1}{2} \gamma h^2 b$$

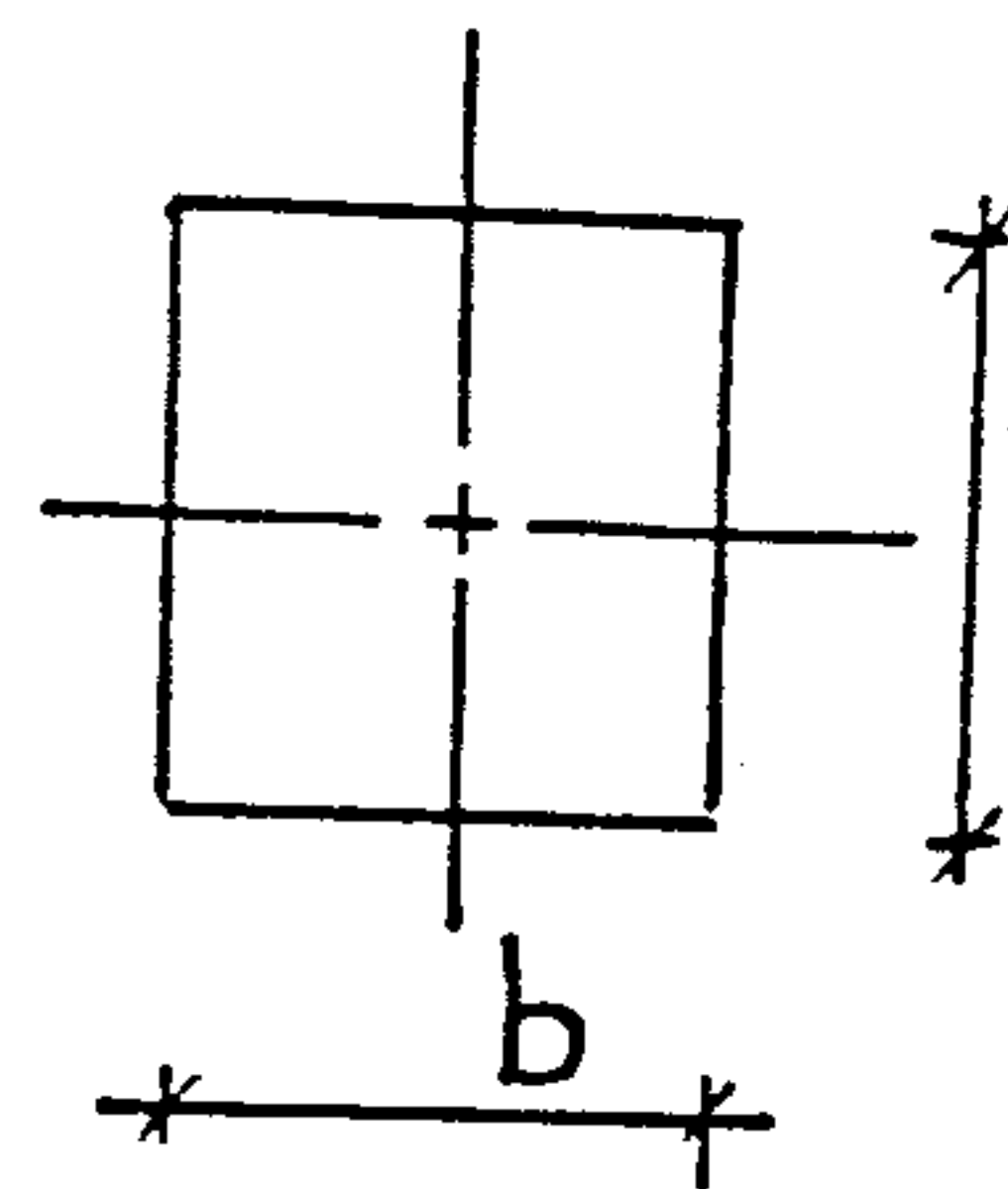
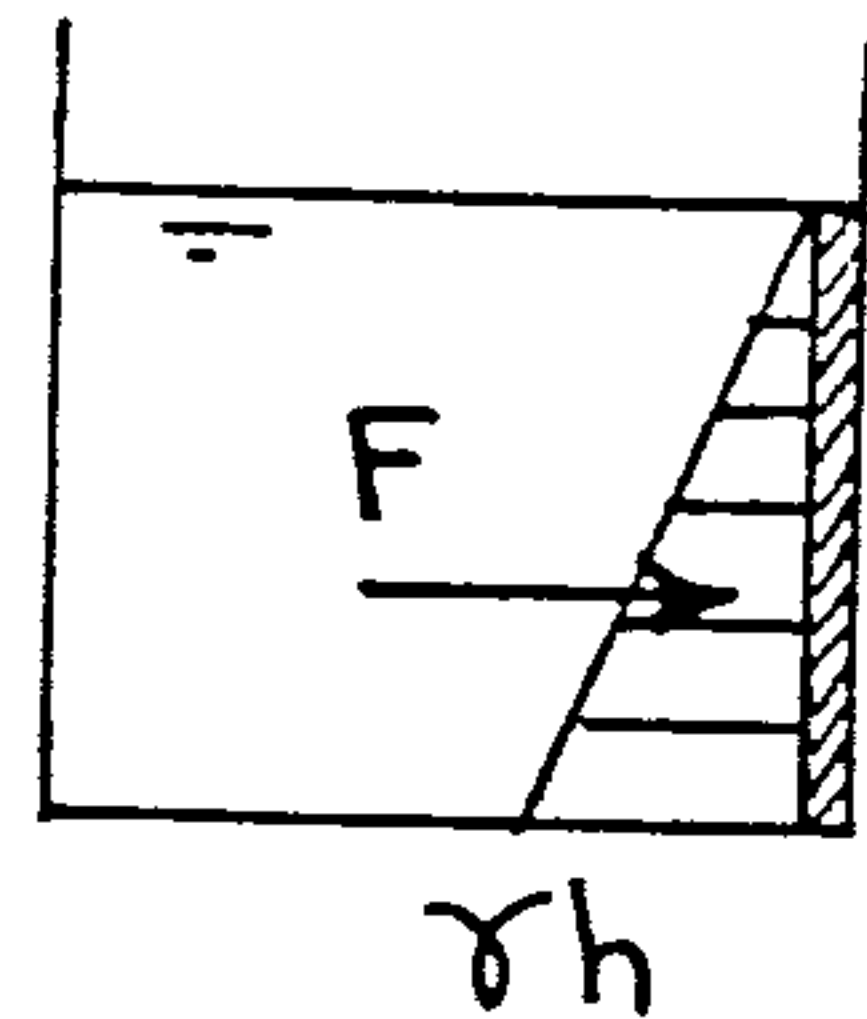
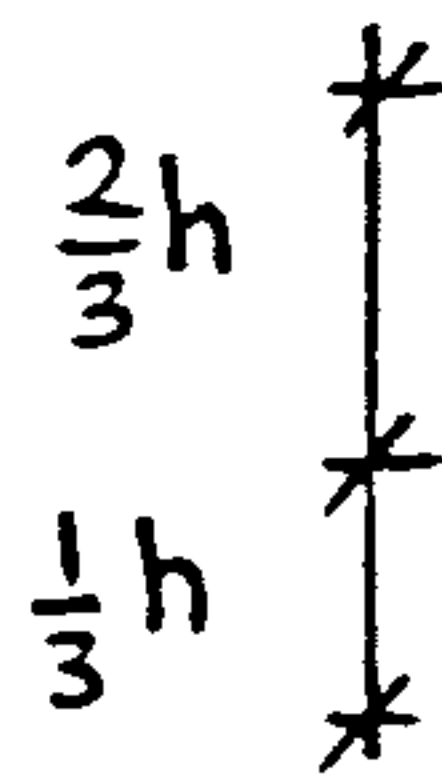

طريقة المعادلات

$$F = \gamma A \bar{h}$$

$$A = bh$$

$$\bar{h} = \frac{h}{2}$$

$$F = \gamma bh \frac{h}{2} = \frac{1}{2} \gamma h^2 b$$

Closed tank with +ve pressure

$$F_1 = (\gamma h_1 + P) h_2 b$$

$$F_2 = \frac{1}{2} (\gamma h_2) h_2 b$$

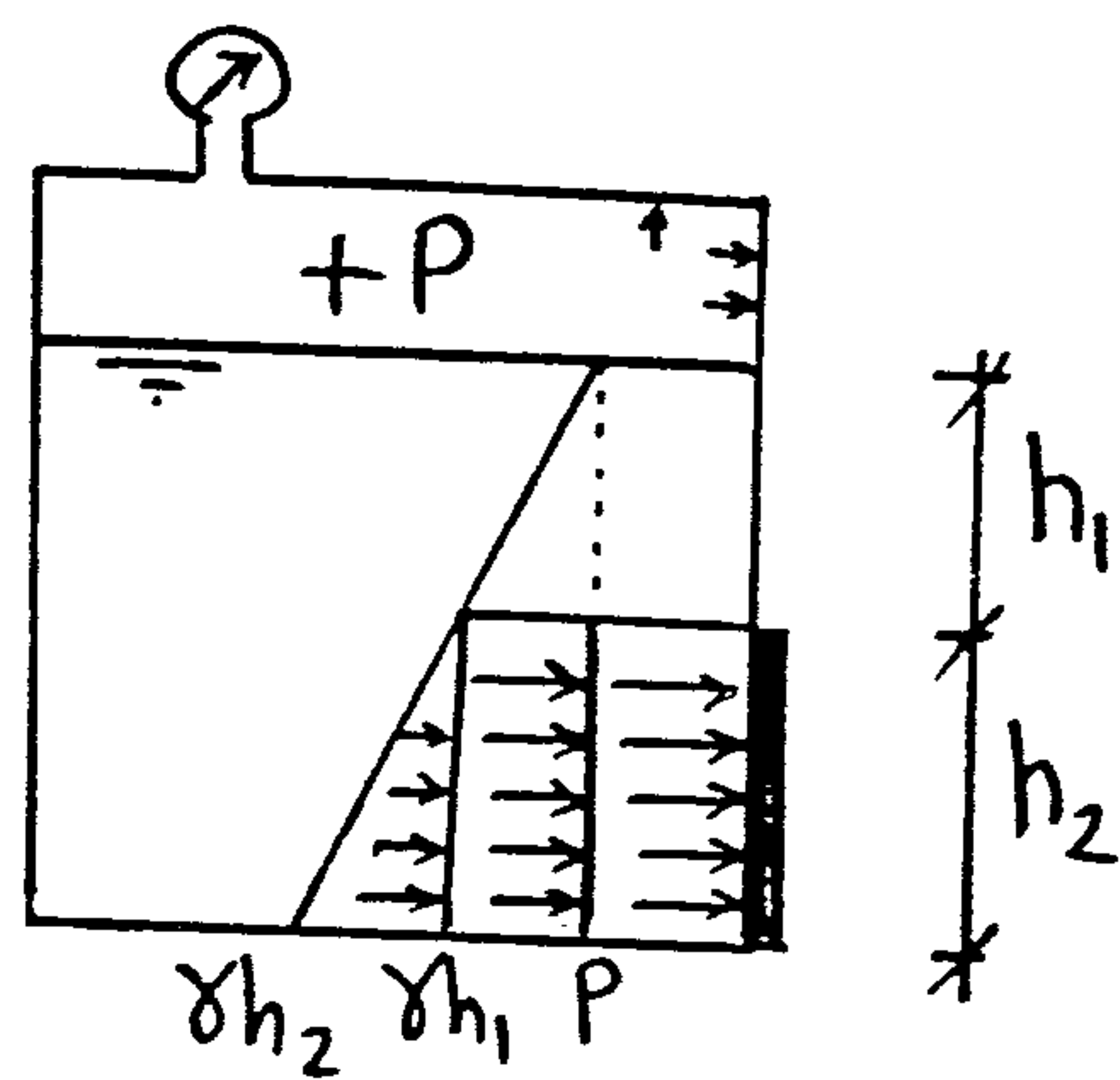
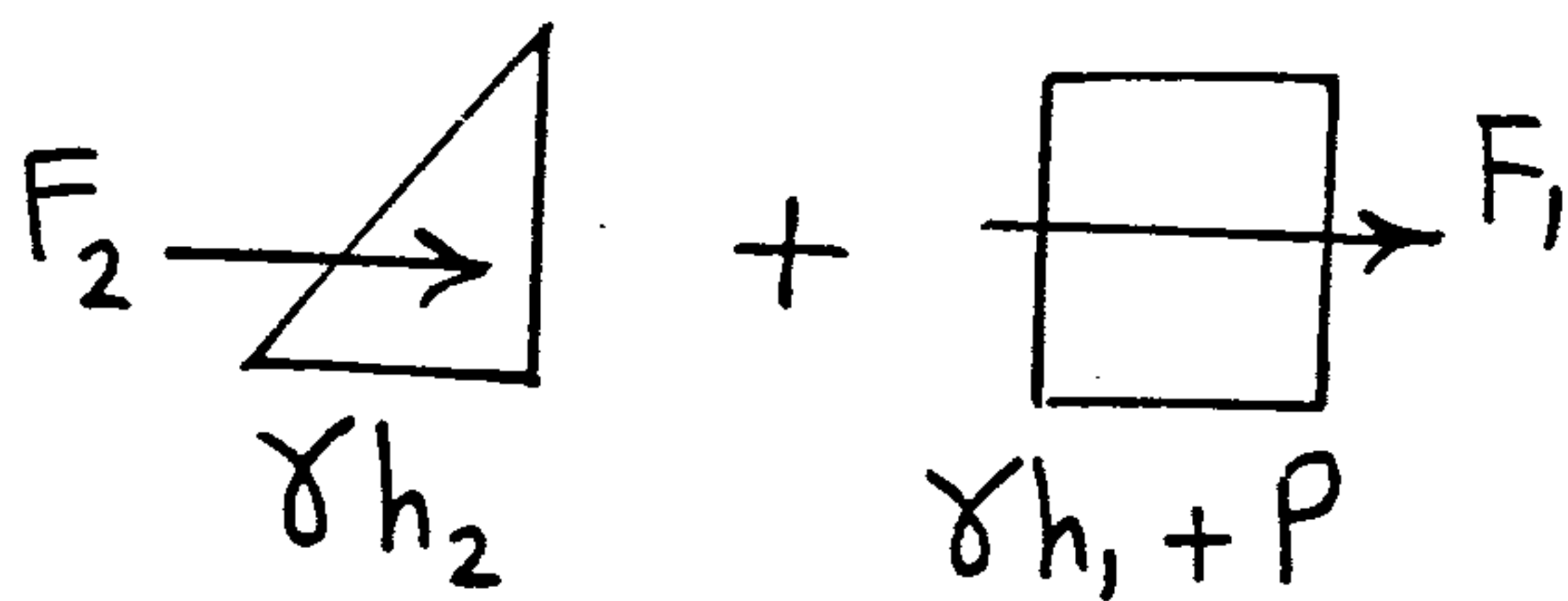

Closed tank with -ve pressure

$$F_1 = (\gamma h_1 - P) h_2 b$$

$$F_2 = \frac{1}{2} (\gamma h_2) h_2 b$$

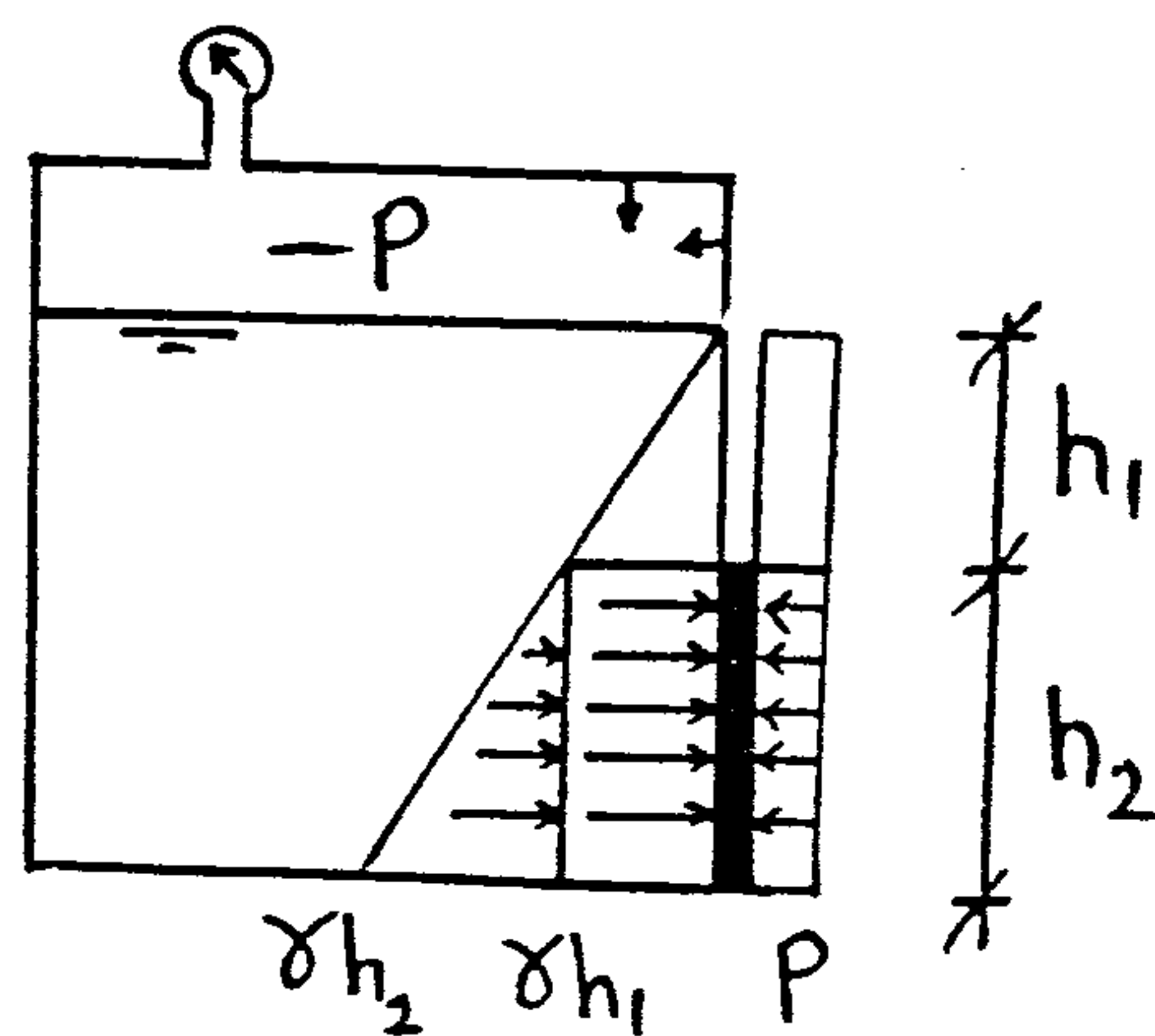
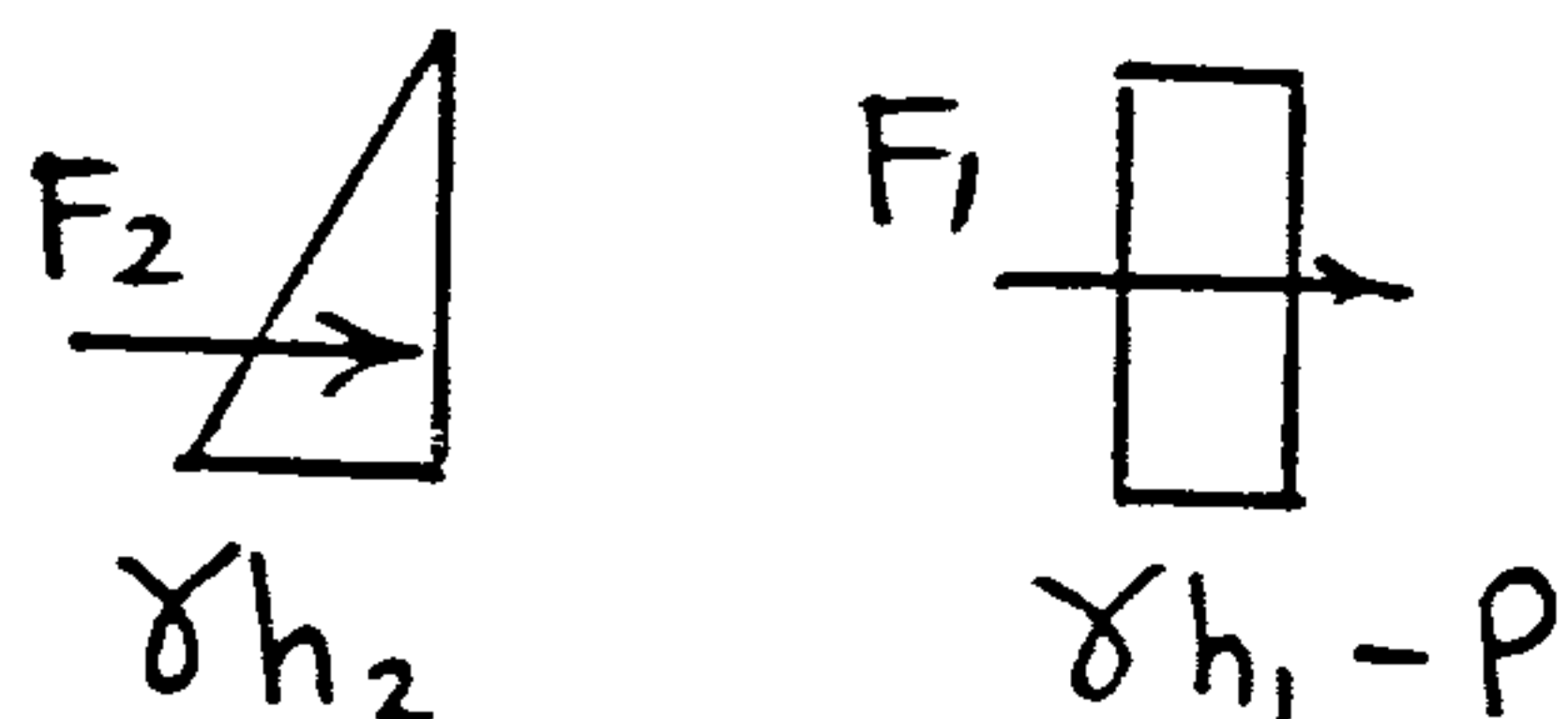

## Inclined surface with 2 fluids

⑧

$$P_1 = \gamma_1 h_1 + \gamma_2 h_2$$

$$P_2 = P_1 + \gamma_2 h_3$$

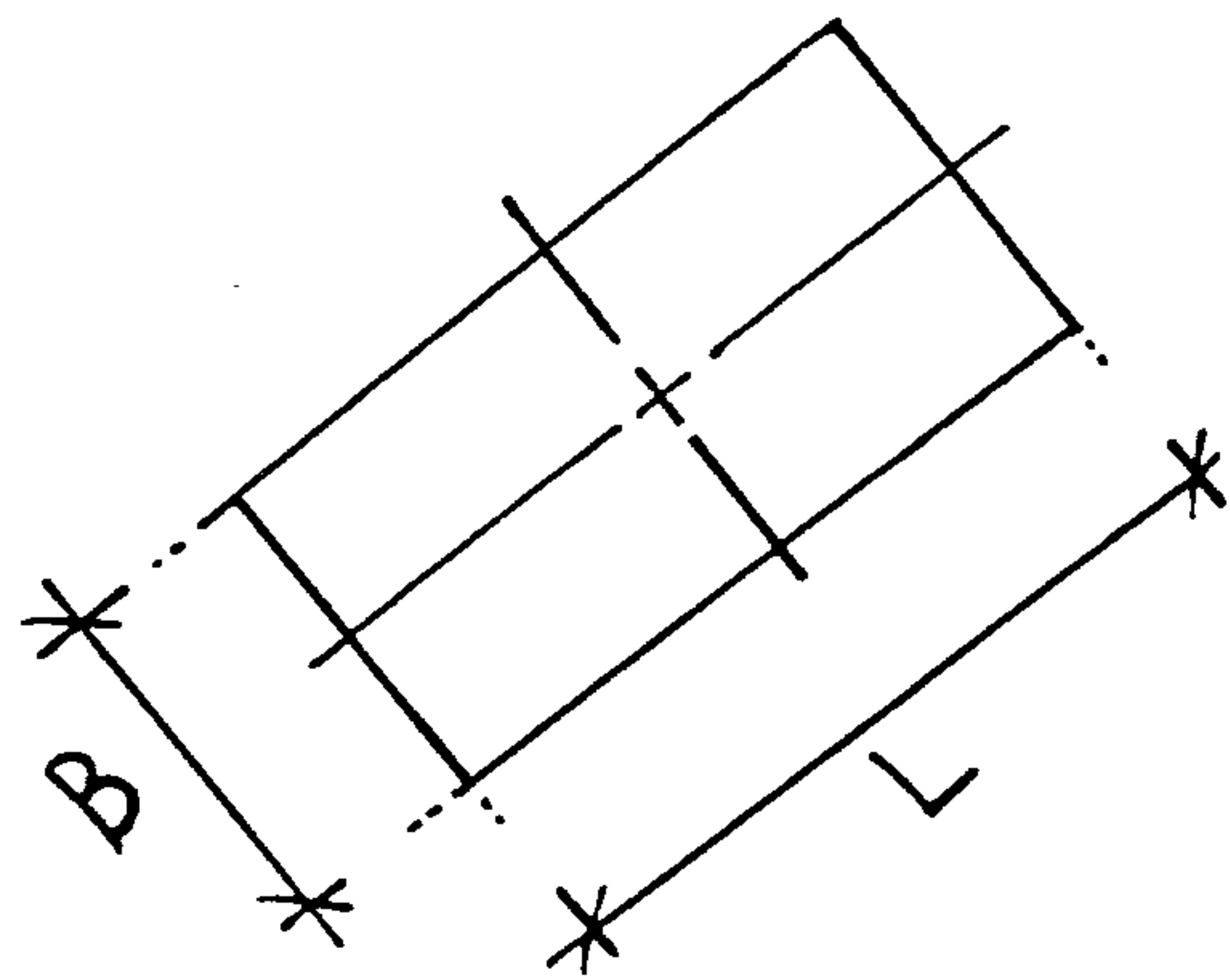
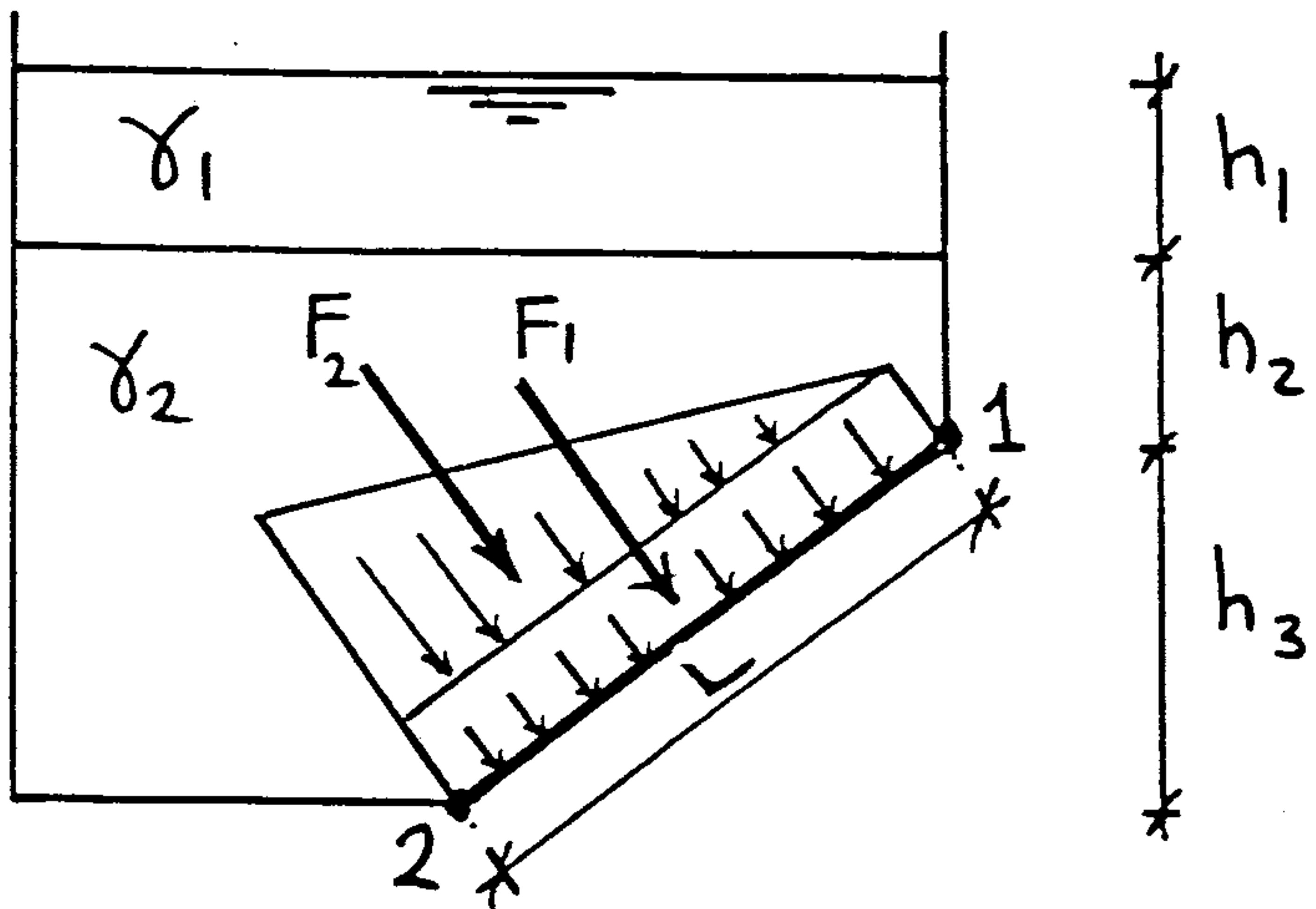
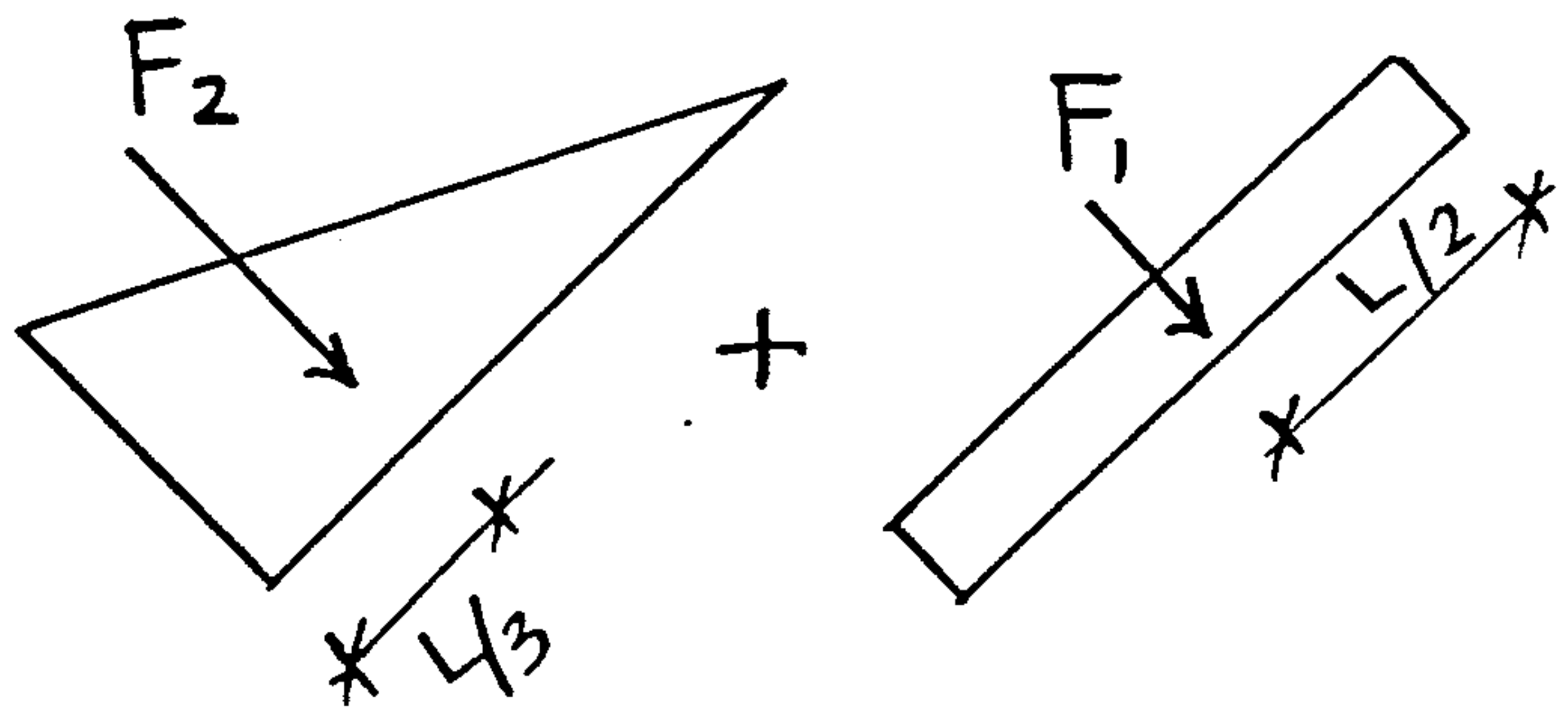

$$F_1 = P_1 A = (\gamma_1 h_1 + \gamma_2 h_2) LB$$

$$F_2 = \frac{(P_2 - P_1) A}{2} = \frac{1}{2} \gamma_2 h_3 LB$$

## 3- Imaginary Free Surface (I.F.S.)

فكرة هذه الطريقة هي محاولة إيجاد Free Surface للبوابة المغمورة في السائل

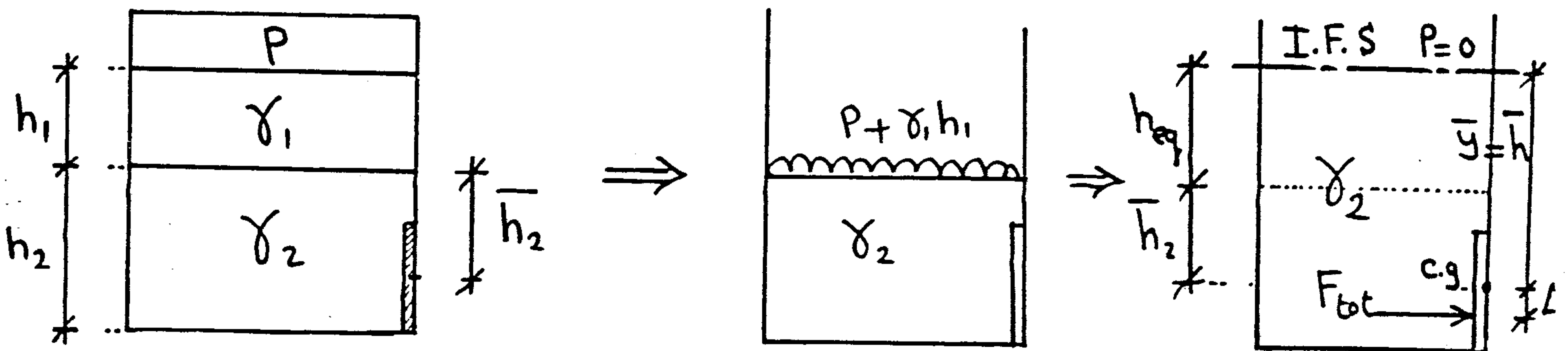

يتم تحويل الضغط الناتج عن السائل  $\gamma_1 h_1$  والضغط  $P$  إلى ارتفاع مكافئ من السائل  $\gamma_2$

$$h_{eq} = \frac{P + \gamma_1 h_1}{\gamma_2}$$

$$F_{total} = \gamma_2 A \bar{h}$$

$$\Delta = \frac{I_{c.g.}}{A \bar{y}}$$

$$\bar{u} = \dots$$



# Gate Subjected to 2 fluids

9

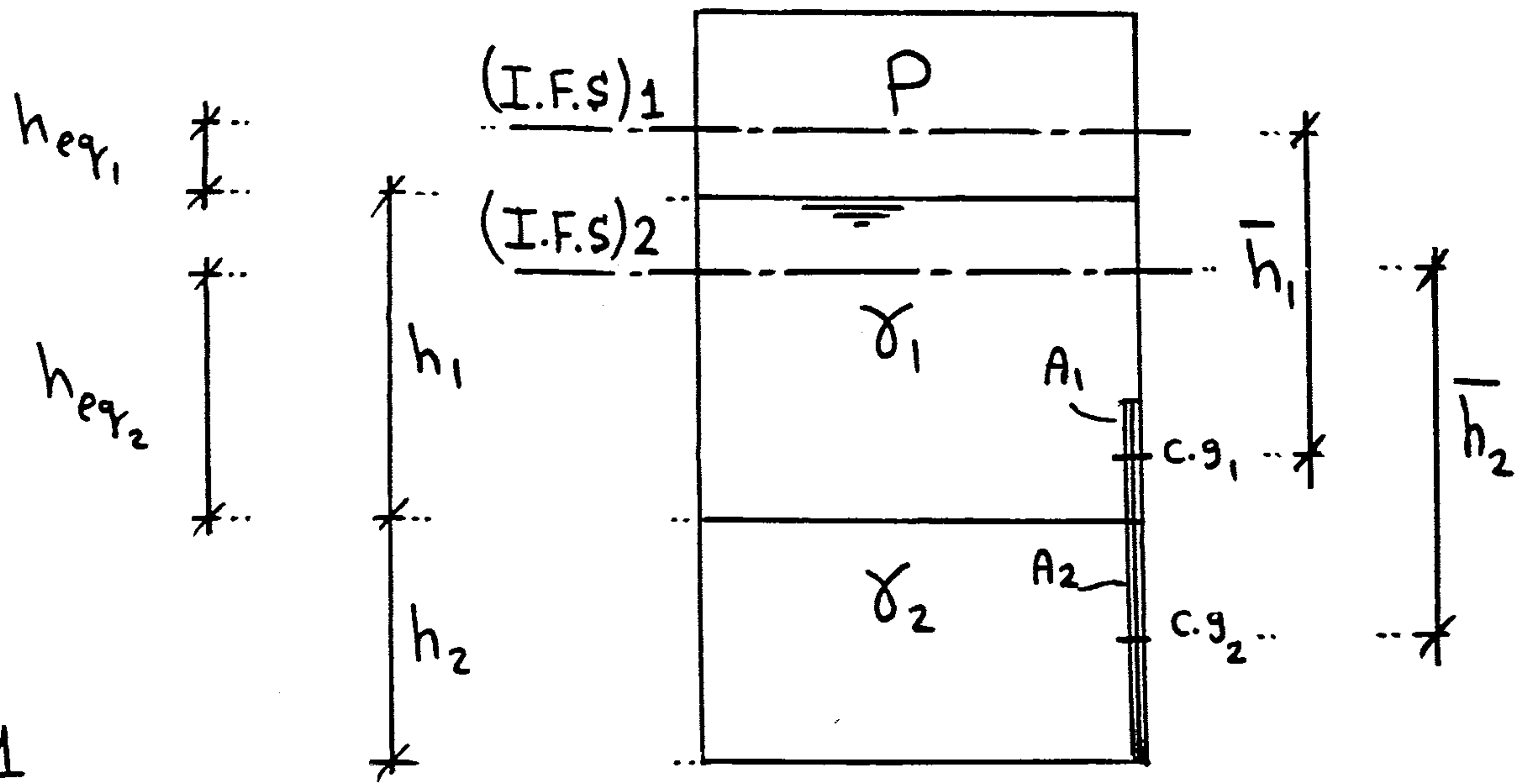

for Area 1

$$h_{eq} = \frac{P}{\gamma_1} \Rightarrow \text{get } \bar{h}_1$$

$$F_1 = \gamma A_1 \bar{h}_1$$

$$\Delta_1 = \frac{I_{c.g.1}}{A_1 \bar{y}_1}$$

$$\bar{y} = \bar{h}_1$$

for Area 2

$$h_{eq_2} = \frac{P + \gamma_1 h_1}{\gamma_2} \Rightarrow \text{get } \bar{h}_2$$

$$F_2 = \gamma A_2 \bar{h}_2$$

$$\Delta_2 = \frac{I_{c.g.2}}{A_2 \bar{y}_2}$$

$$F = F_1 + F_2$$

$$F_2 d = F Z \Rightarrow \text{get } Z \text{ (line of action)}$$

نتعامل مع كل مادة على حدة

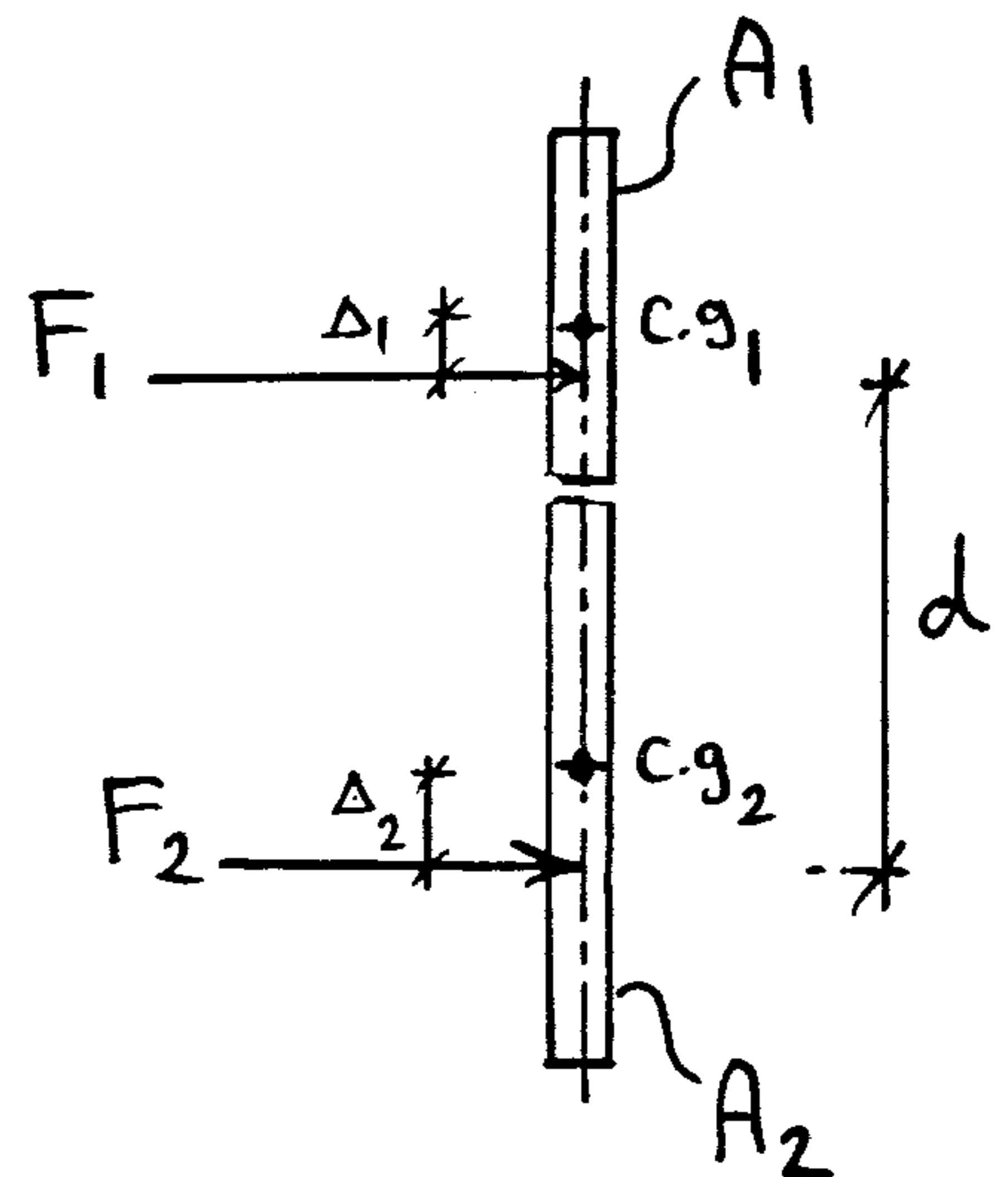

5

# Forces on Curved Surfaces

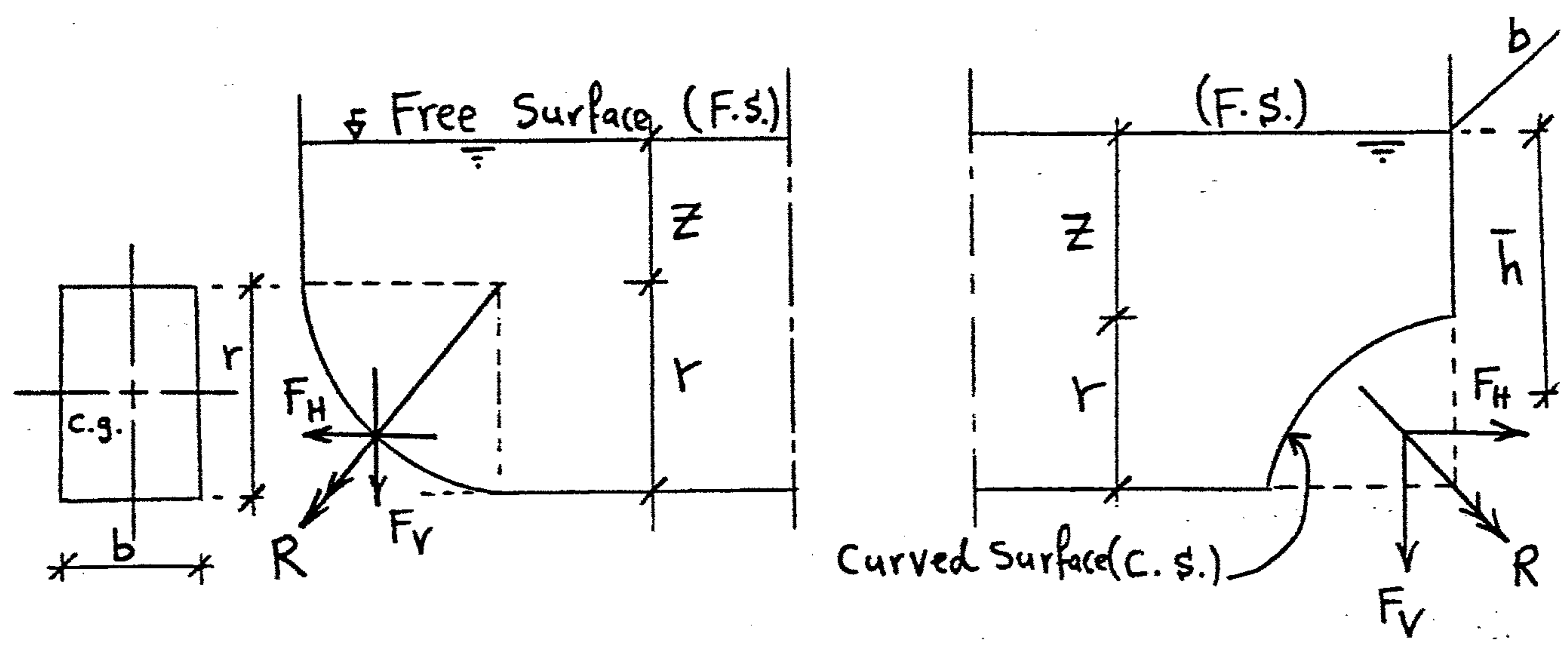

يؤثر الضغط عمودياً على أي سطح، فإذا كان السطح دائرياً مرت المحصلة R في مركزه  
ولمعرفة اتجاه R نفترض وجود ثقب في ال Curved Surface فيكون اتجاه خروج السائل  
هو اتجاه R

يتم تحليل المحصلة R إلى مركبتين، مركبة أفقية F<sub>H</sub> ومركبة رأسية F<sub>V</sub>

## F<sub>H</sub> (Horizontal Component)

المركبة الأفقية F<sub>H</sub> هي عبارة عن القوى المؤثرة على (مسقط ال Curved Surface على مستوى رأسي)

$$F = \gamma A \bar{h}$$

Where;  $A = br$      $\bar{h} = z + \frac{r}{2}$

$$\Delta = \frac{I_{c.g}}{A \bar{y}}$$

$$\bar{y} = \bar{h}$$

$$I_{c.g} = \frac{br^3}{12}$$

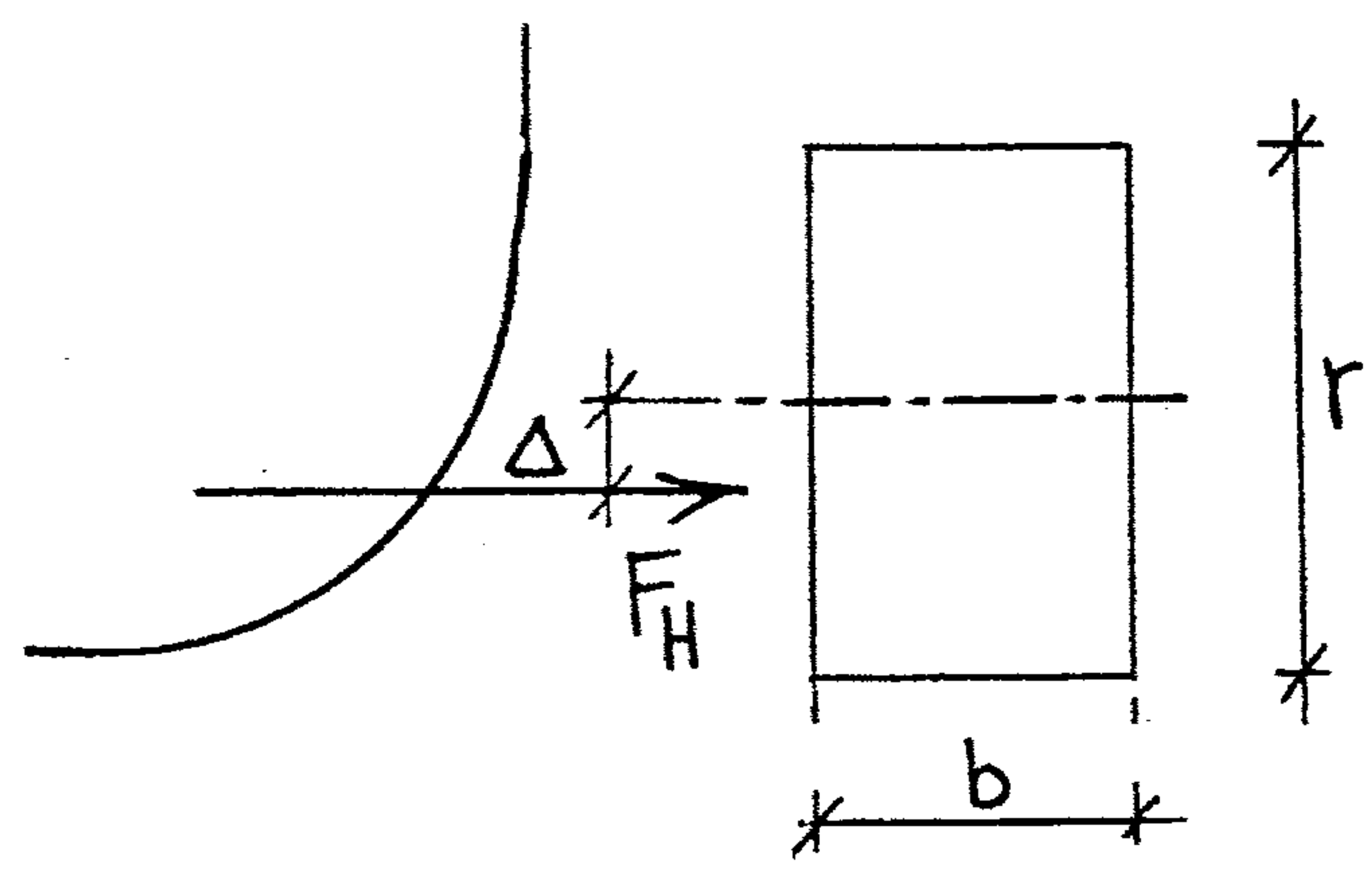

خطوات العمل

يتم إسقاط ال Curved Surface على مستوى رأسي وتعامل مع المساحة المسقطة  
 اتجاه المركبة الأفقية عمودياً على المساحة المسقطة  
 وخط عملها يمر أسفل مركز المساحة المسقطة بمسافة  $\Delta$

$F_v$  (Vertical Component)

المركبة الرأسية  $F_v$  هي عبارة عن وزن السائل المحصور بين ال Curved Surface ومسقطه  
 على ال Free Surface

$$F_v = \gamma V$$

خطوات العمل

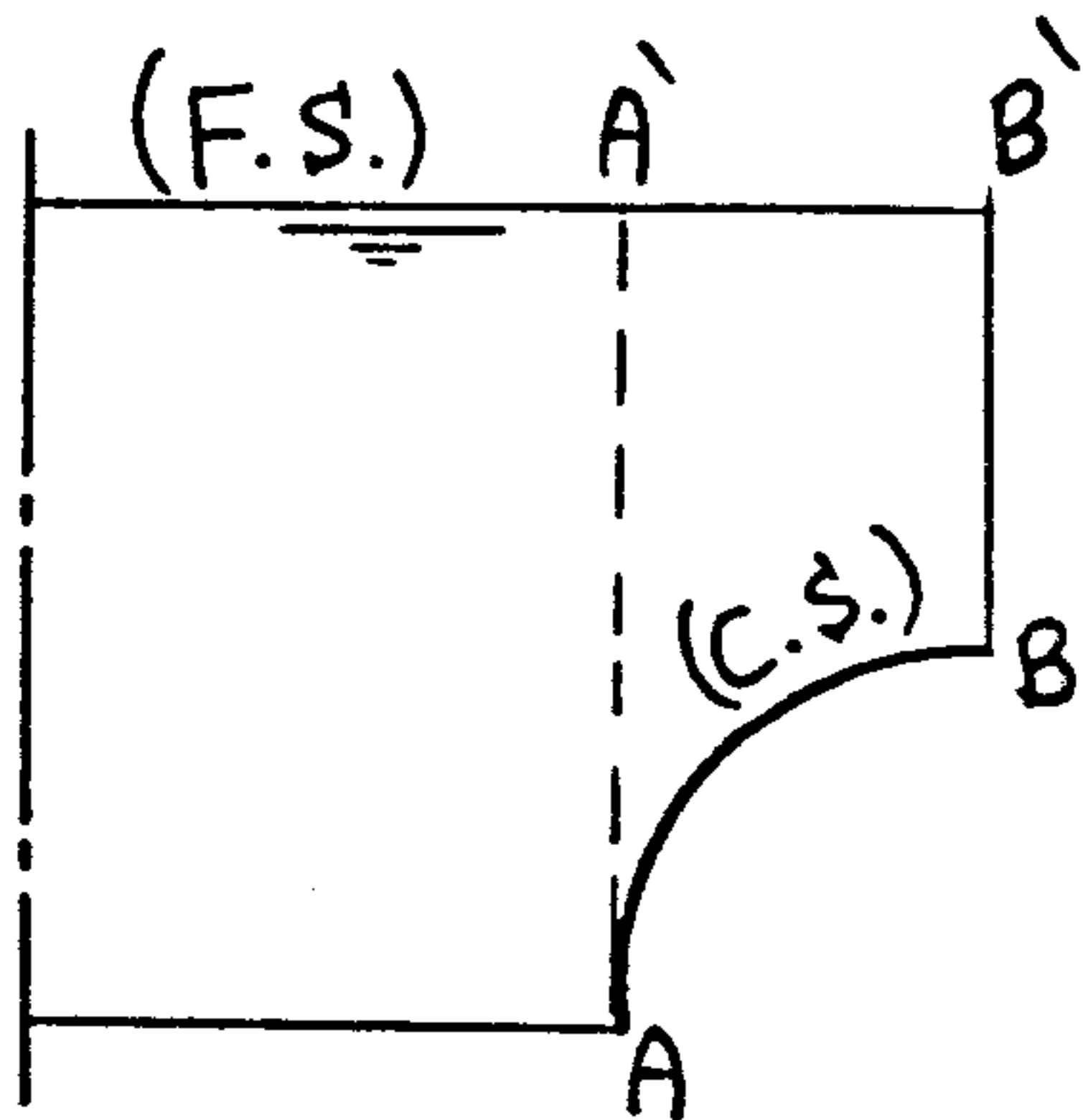

يتم إسقاط أعلى وأسفل نقطة لل Curved Surface على  
 ال Free Surface بشرط ألا تكون بينهما نقطة انقلاب

في حالة عدم وجود نقطة انقلاب

يتم إسقاط أسفل نقطة A وأعلى نقطة B لل Curved Surface  
 على ال Free Surface في A', B'

وتكون المركبة الرأسية  $F_v$  هي عبارة عن وزن السائل المحصور بين ال (C.S.) AB  
 ومسقطه على ال (F.S.) A'B'

في حالة وجود نقطة انقلاب

يتم إسقاط أعلى نقطة A ونقطة الانقلاب C على ال (F.S.)

وكذلك إسقاط أسفل نقطة B ونقطة الانقلاب C على ال (F.S.)

وتكون المركبة الرأسية هي عبارة عن الفرق في الوزن بين 1,2

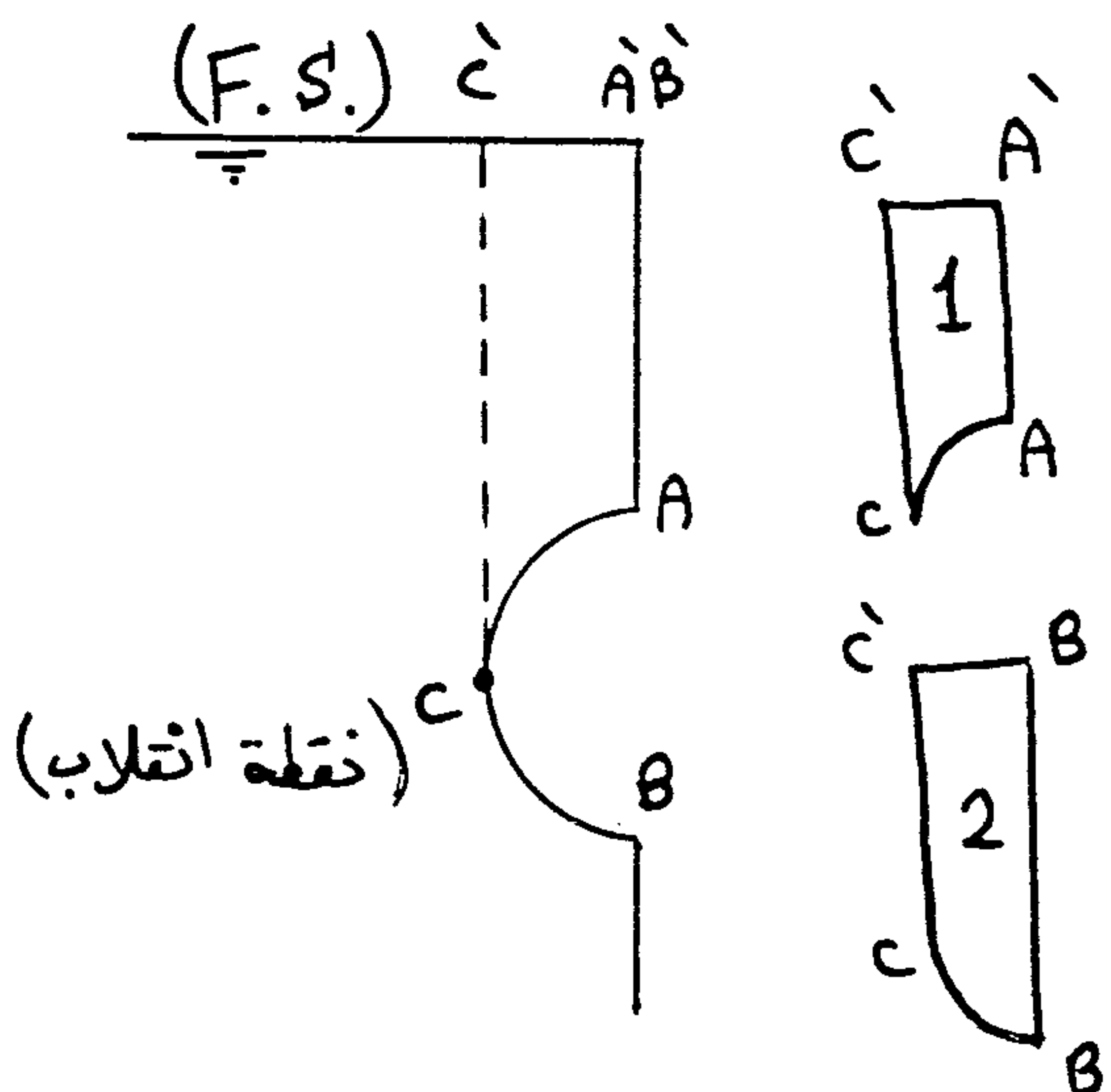

اتجاه  $F_V$

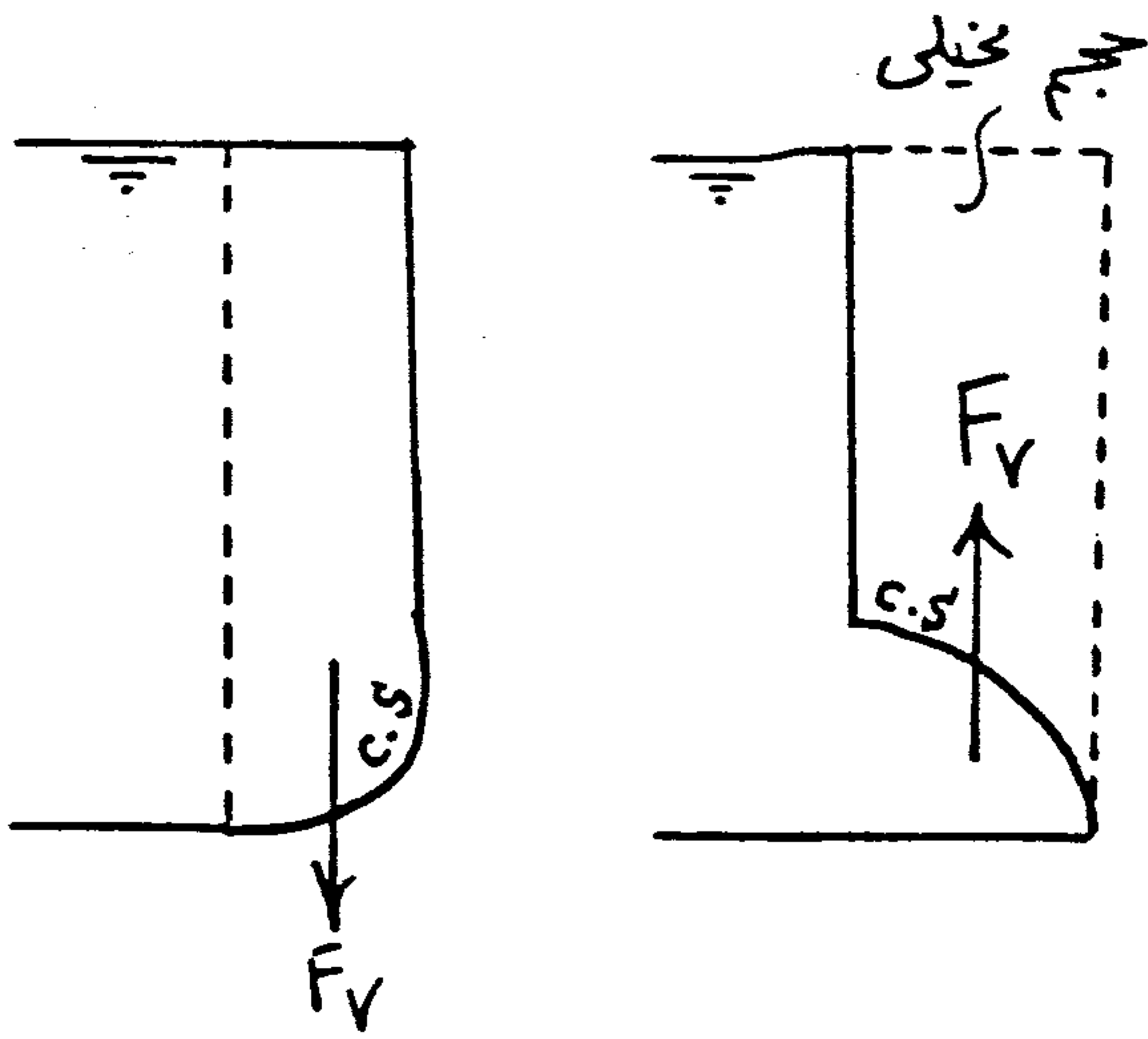

لو كان السائل فوق ال C.S. تؤثر  $F_V$  رأسياً لأسفل ↓

لو كان السائل أسفل ال C.S. تؤثر  $F_V$  رأسياً لأعلى ↑

في الحالة الثانية قد لا يتواجد أى سائل فوق

ال Curved Surface لكن القوى  $F_V = \gamma V$

هي عبارة عن قوى مكافئة لوزن نفس السائل محتويًا على حجم تخيلي فوق ال Curved

Surface وحتى ال Free Surface واتجاهه لأعلى

خط عمل  $F_V$

تؤثر القوى  $F_V$  في مركز ثقل الحجم المحصور بين ال Curved Surface وال Free Surface

e.g.

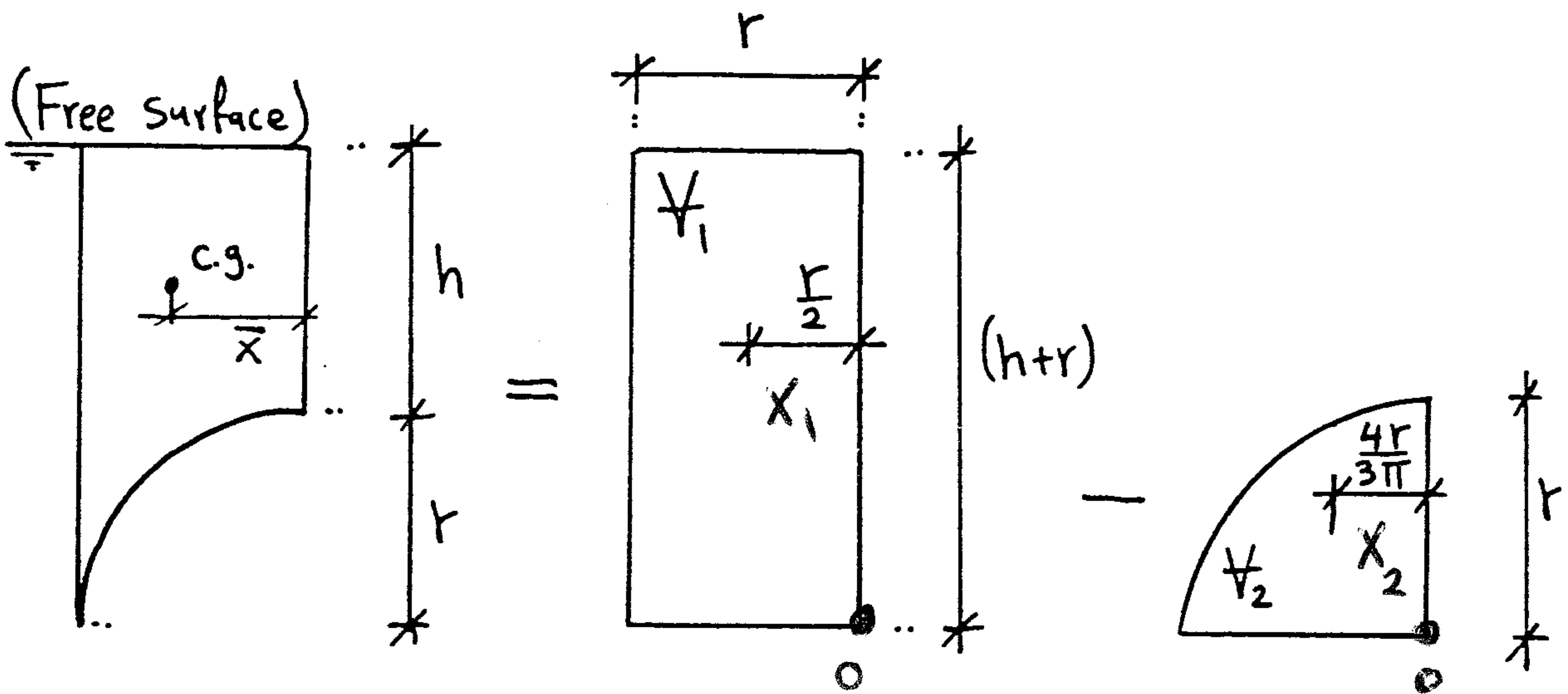

$$V_1 = (h+r) r b$$

$$X_1 = \frac{r}{2}$$

$$V_2 = \frac{1}{4} \pi r^2 b$$

$$X_2 = \frac{4r}{3\pi}$$

$$V = V_1 - V_2$$

$$F_V = \gamma V \downarrow$$

$$\bar{X} = \frac{V_1 X_1 - V_2 X_2}{V}$$

6

## Fluid Masses Subjected to Linear Acceleration

①

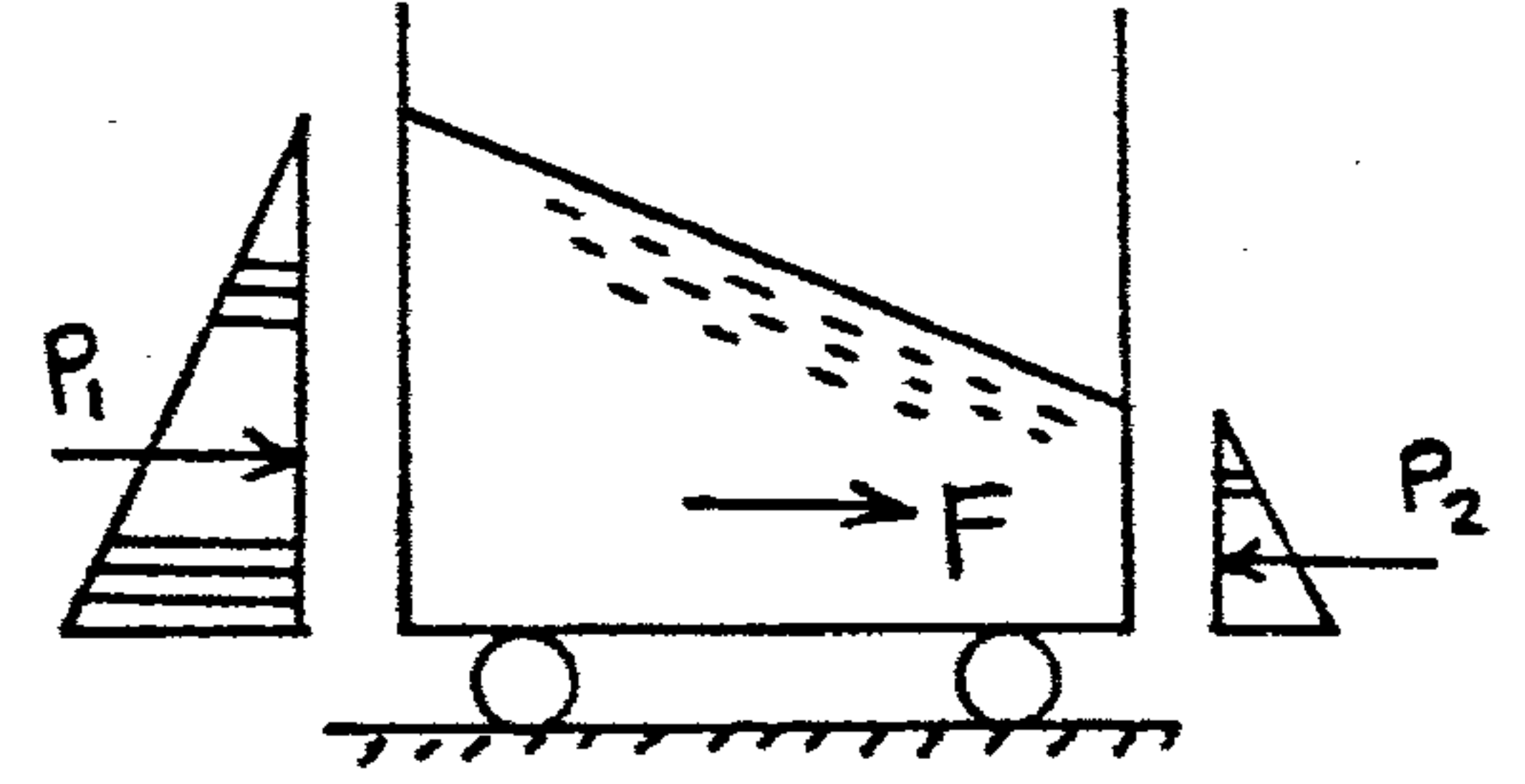
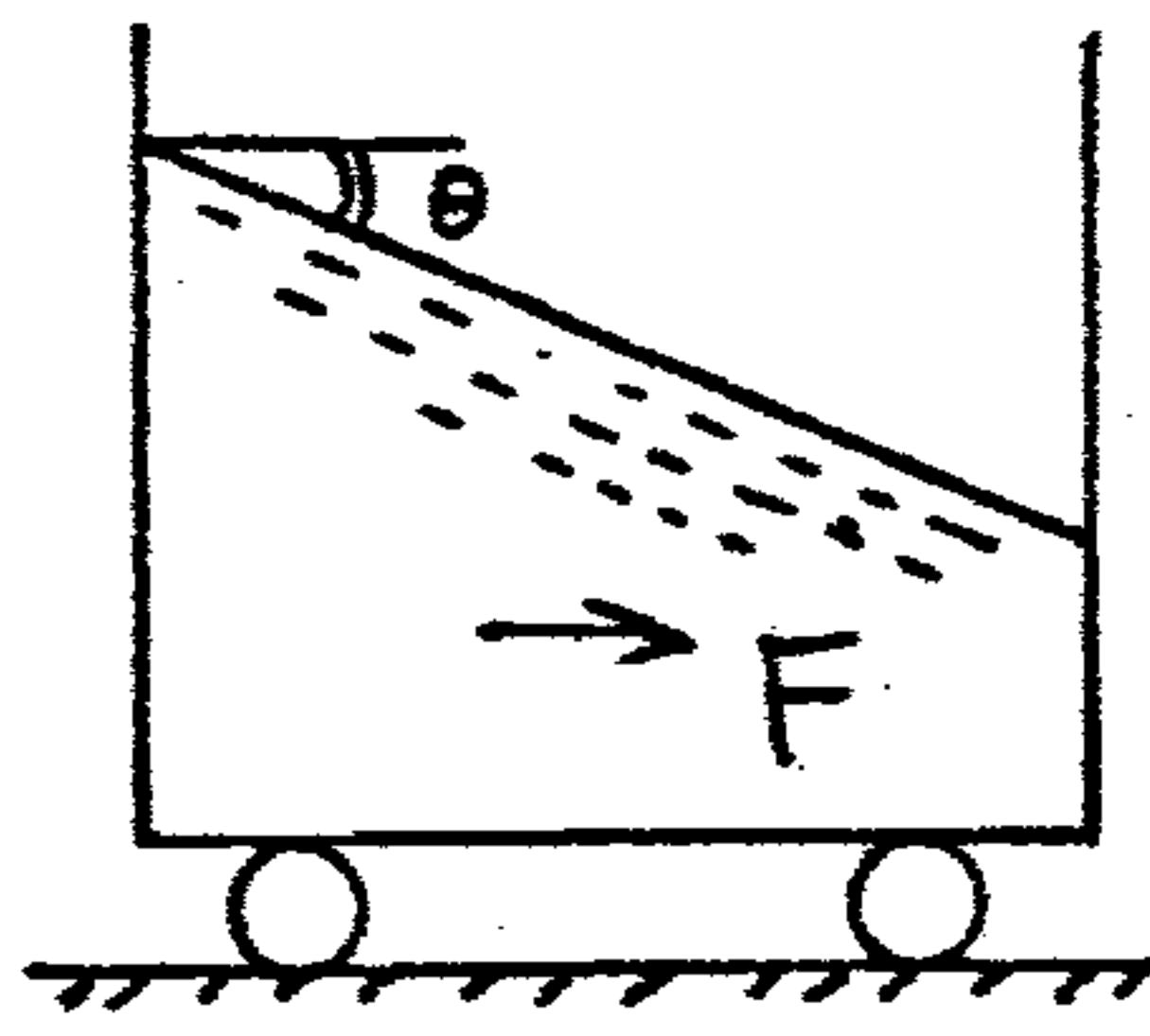
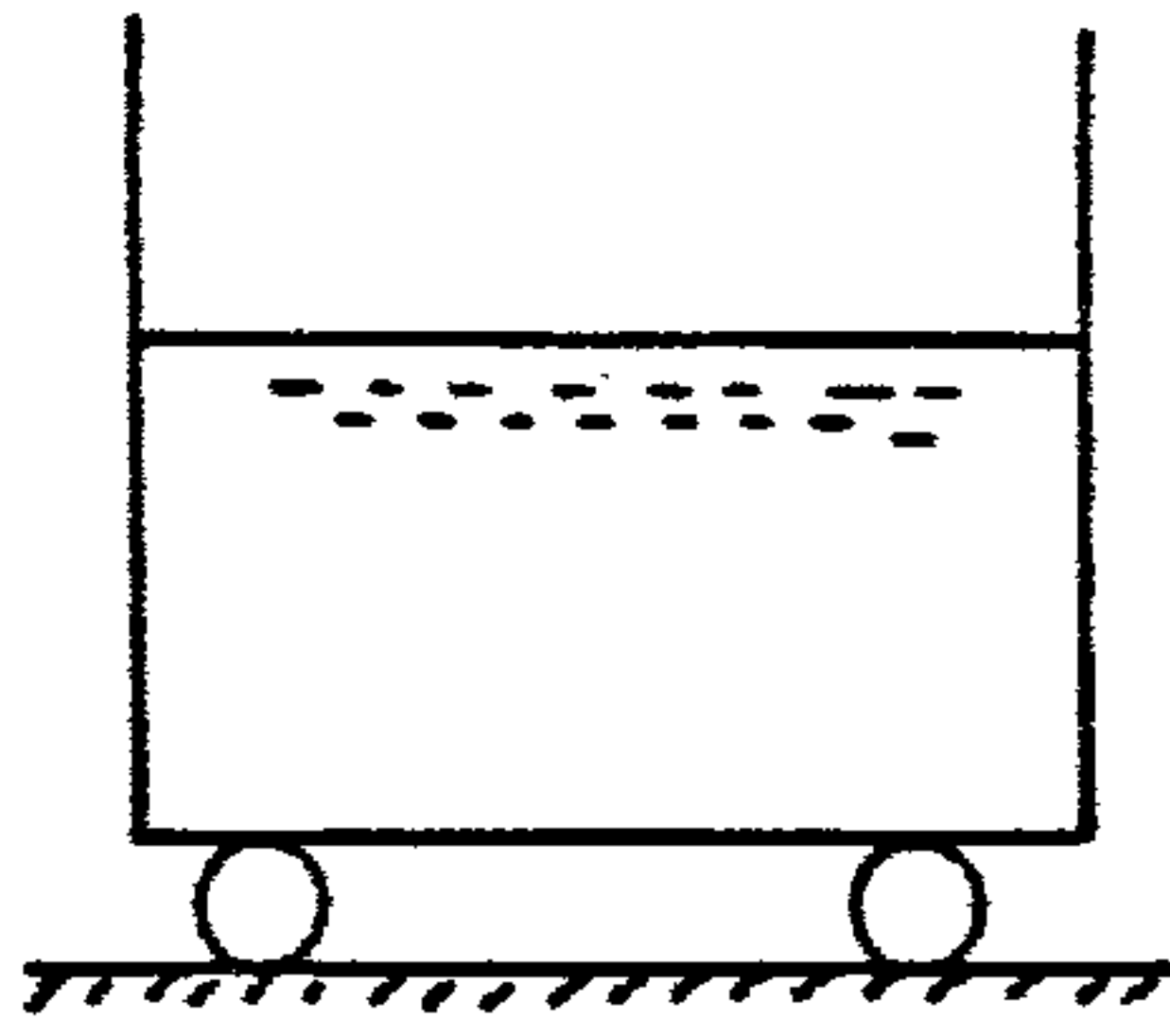

- إذا أعطى سائل في إناء مفتوح عجلة منتظمة "a" **uniform acceleration**
- فإنه بعد زمن معين يتحرك الإناء كوحدة واحدة **moves as a solid body**
- وبالتالي لا توجد حركة نسبية بين جزيئات السائل وبعضها أو بينه وبين الإناء الحاوي له **(no shear stresses)**
- في هذه الحالة يمكن تطبيق قوانين ال **Static fluid** لكن بإضافة تأثير العجلة.

Assume the acceleration (a) in a given direction and its Components  $a_x$  ,  $a_z$

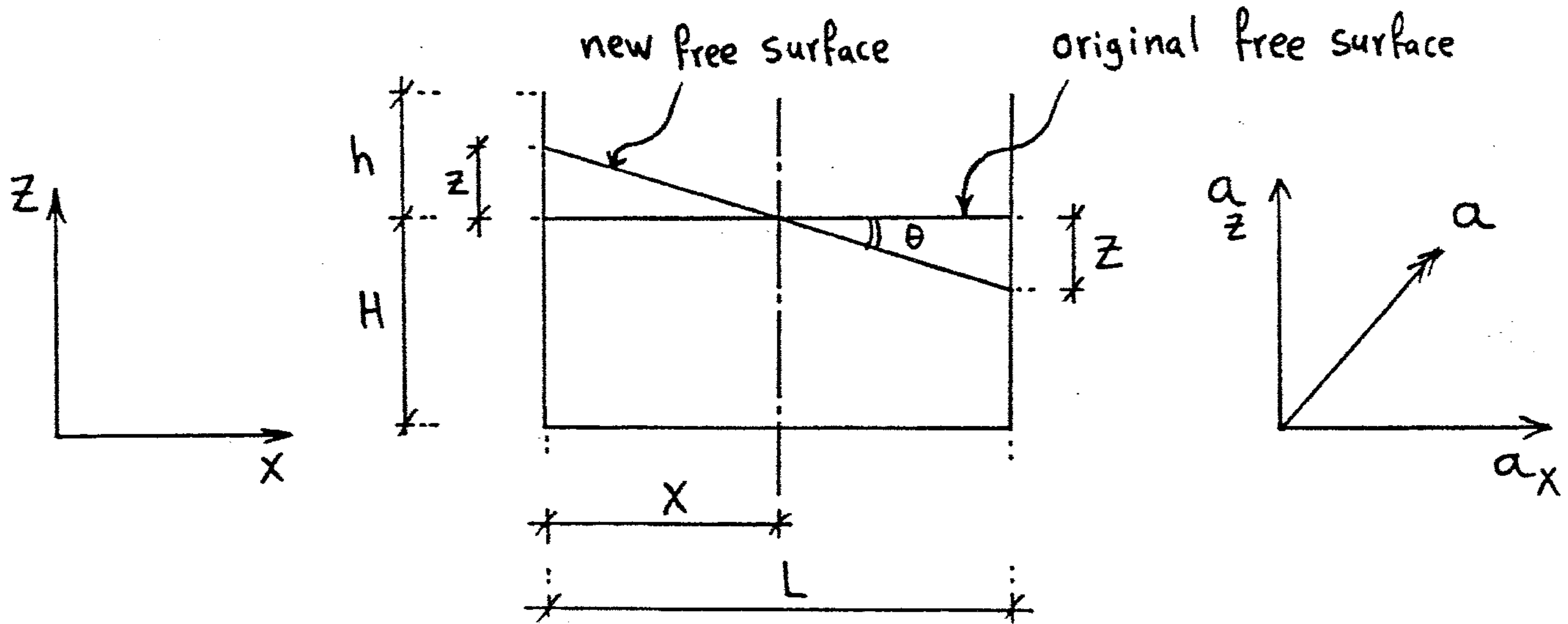

$a_x$  : العجلة في الاتجاه الأفقى

$a_z$  : العجلة في الاتجاه الرأسى

$$\tan \theta = \frac{z}{L/2}$$

$\theta$  : الزاوية بين ال Free Surface قبل الحركة وال Free Surface بعد الحركة

## 1 Horizontal acceleration

(2)

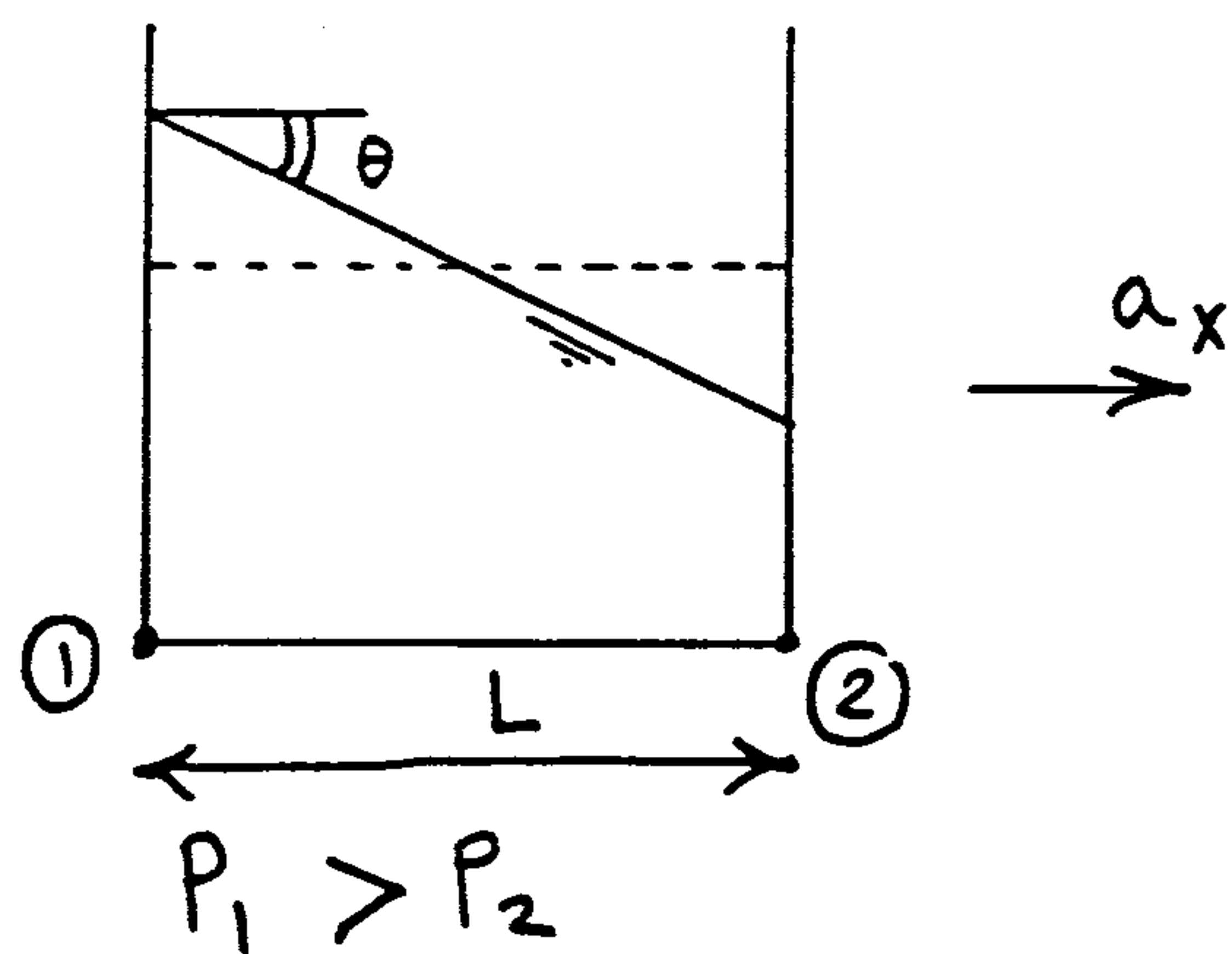
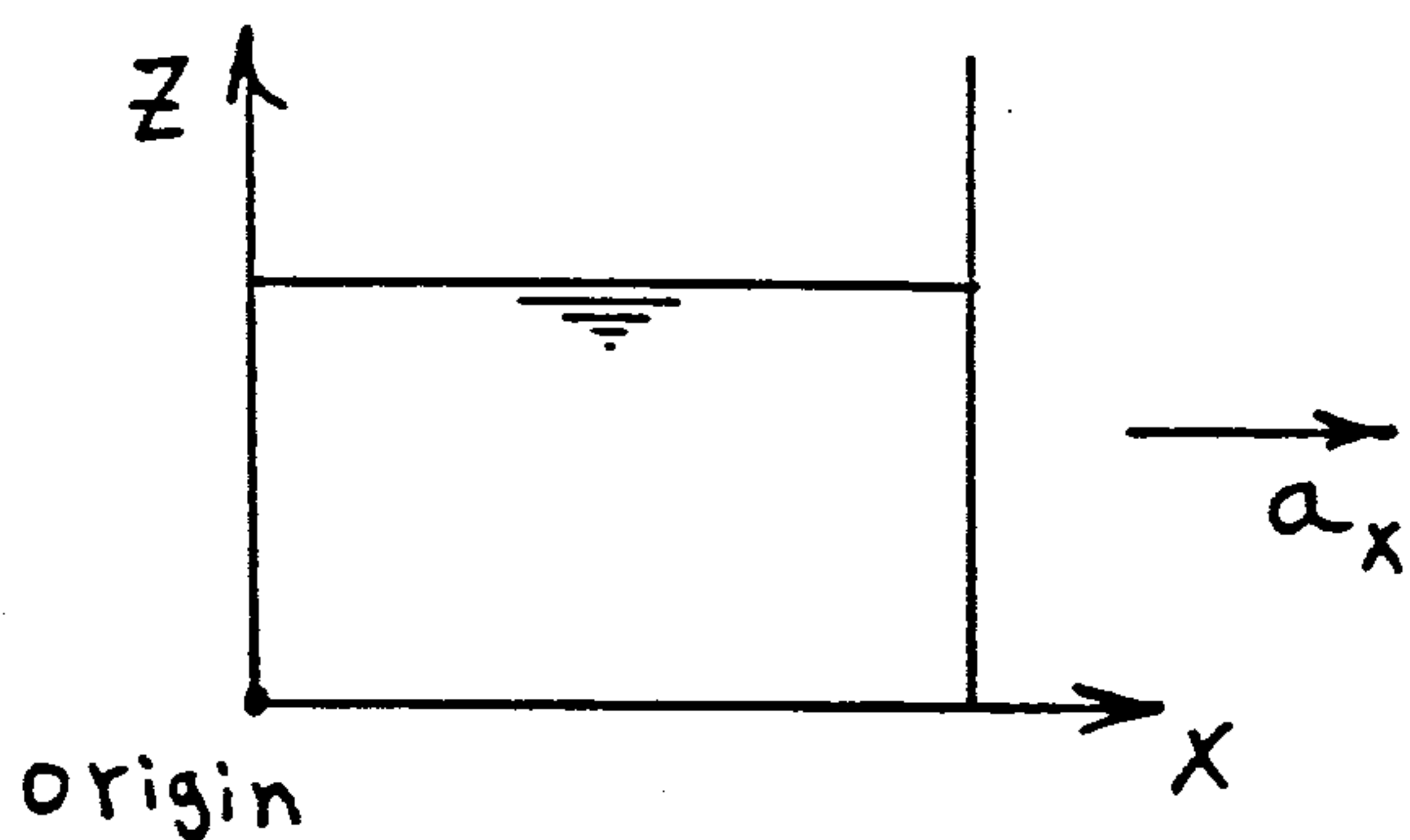

$$\frac{\partial P}{\partial x} = -\frac{\gamma}{g} a_x$$

$$P_2 = P_1 - \frac{\gamma}{g} a_x L$$

من هذه المعادلة نستنتج أن الضغط يتغير في الاتجاه الأفقي وإشارة السالب تعني أن الضغط يقل كلما اتجهنا في اتجاه العجلة (إلى اليمين)  
 ∴ أسطح تساوي الضغط ليست أفقية لكن تميل بزاوية  $\theta$

$$* \text{ If } a_x = 0 \Rightarrow \frac{\partial P}{\partial x} = 0$$

في حالة عدم وجود عجلة أفقية  $a_x$  أو كان السائل يتحرك بسرعة منتظمة (uniform velocity) فإنه لا يوجد تغير في الضغط في الاتجاه الأفقي ويكون سطح السائل أفقياً تماماً

## 2 Vertical acceleration

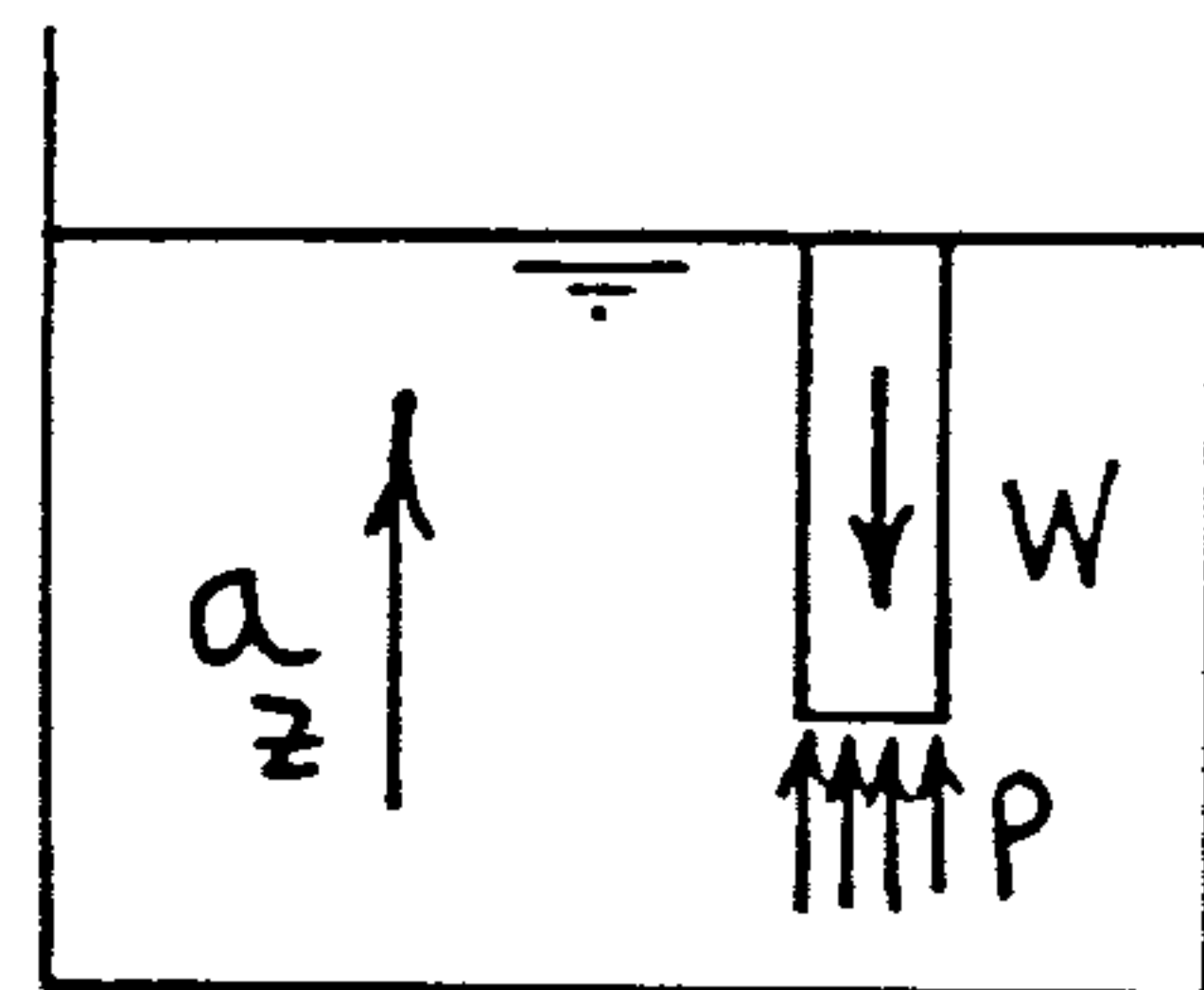

$$\frac{\partial P}{\partial z} = -\frac{\gamma}{g} (g \pm a_z)$$

- إذا تحرك tank محتوياً على سائل رأسياً إلى أعلى بعجلة منتظمة  $a_z$   
 فإن الضغط يزداد طردياً مع زيادة العجلة الرأسية إلى أعلى ويظل سطح السائل أفقياً ما لم يتعرض إلى عجلة أفقية  $a_x$

$$* \text{ If } a_z = 0 \Rightarrow \frac{\partial P}{\partial z} = -\gamma$$

③

$$P = \frac{\gamma}{g} (g \pm a_z) h = \gamma' h$$

$$\gamma' = \frac{\gamma}{g} (g \pm a_z)$$

### ③ Combined Horizontal and Vertical acceleration

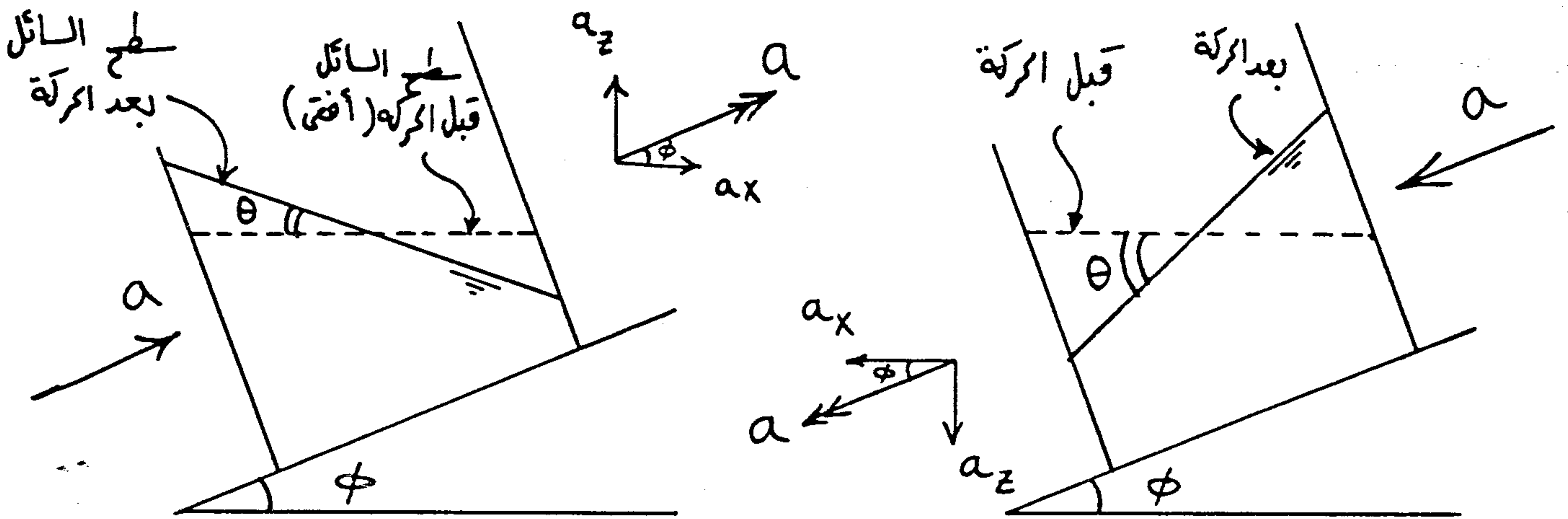

$$\tan \theta = \frac{a_x}{g \pm a_z}$$

$$a_x = a \cos \phi$$

$$a_z = a \sin \phi$$

$a_z \rightarrow (+ve) \Leftarrow$  لو كان  $a_z$  لأعلى

$a_z \rightarrow (-ve) \Leftarrow$  لو كان  $a_z$  لأسفل

\* If  $a_x = 0 \Rightarrow \tan \theta = 0$

في حالة عدم وجود عجلة أفقية فإن سطح السائل يظل أفقياً

\* If  $a_z = 0 \Rightarrow \tan \theta = \frac{a_x}{g}$

# How to Know if liquid will be spilt?

$$\tan\theta = \frac{a_x}{g \pm a_z} = \frac{z}{L/2}$$

⇒ get z

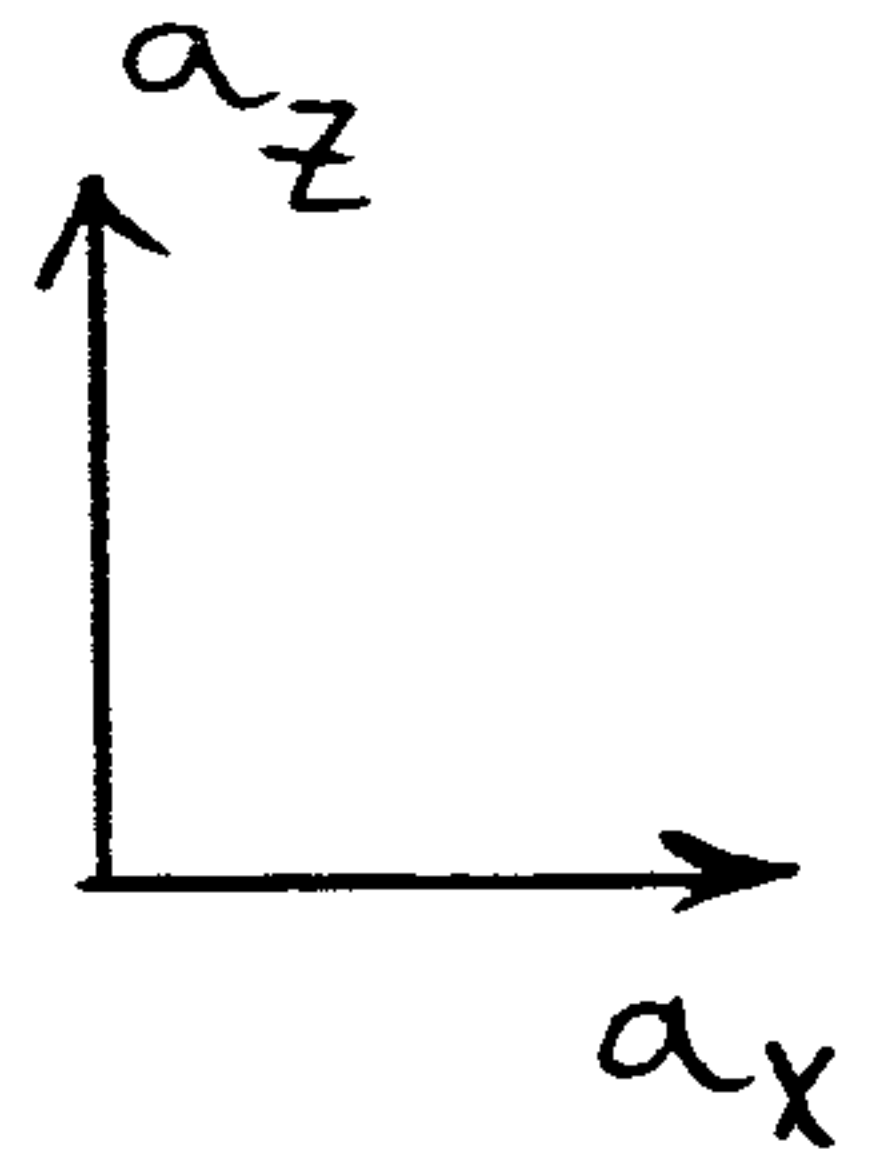
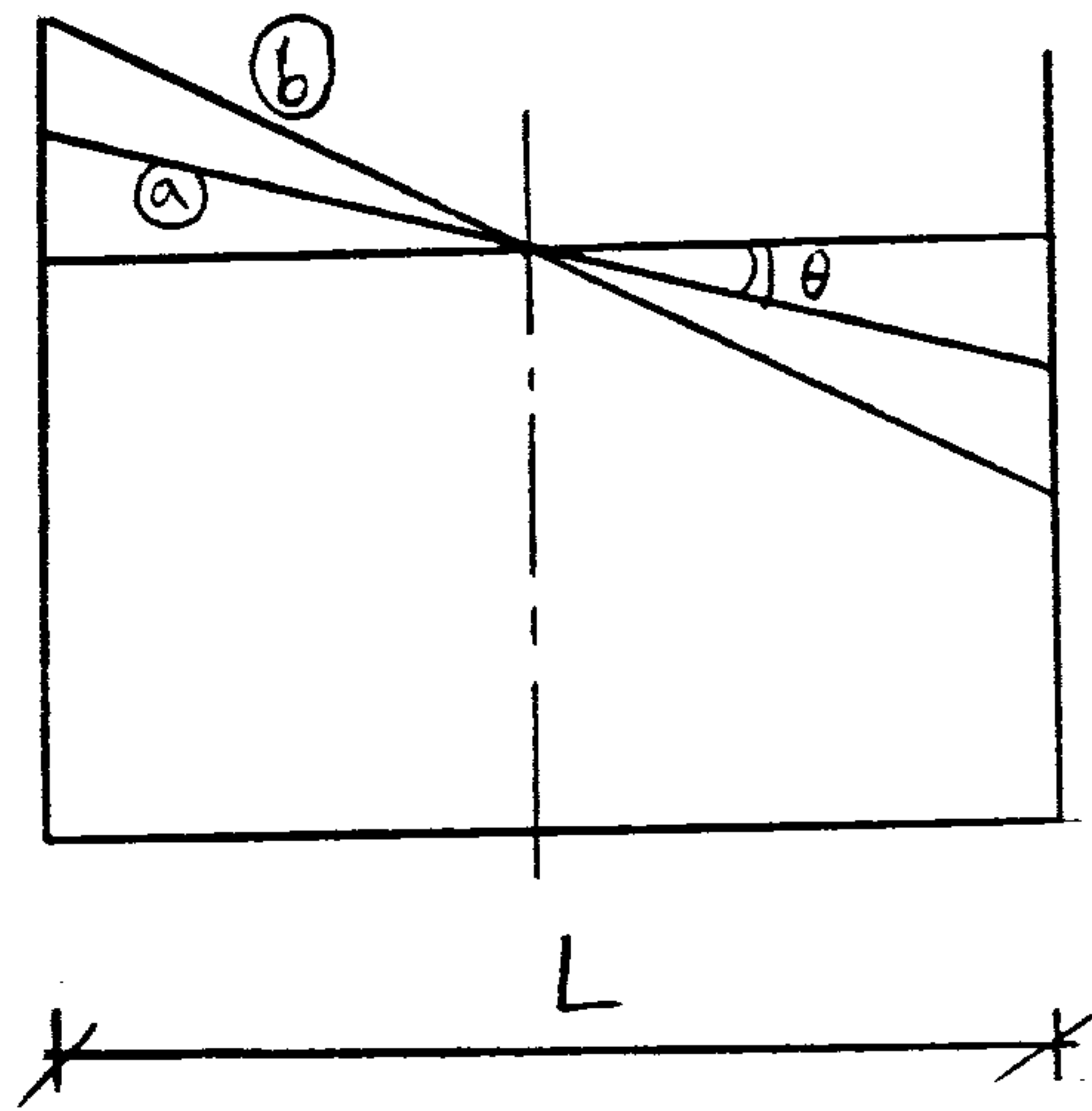
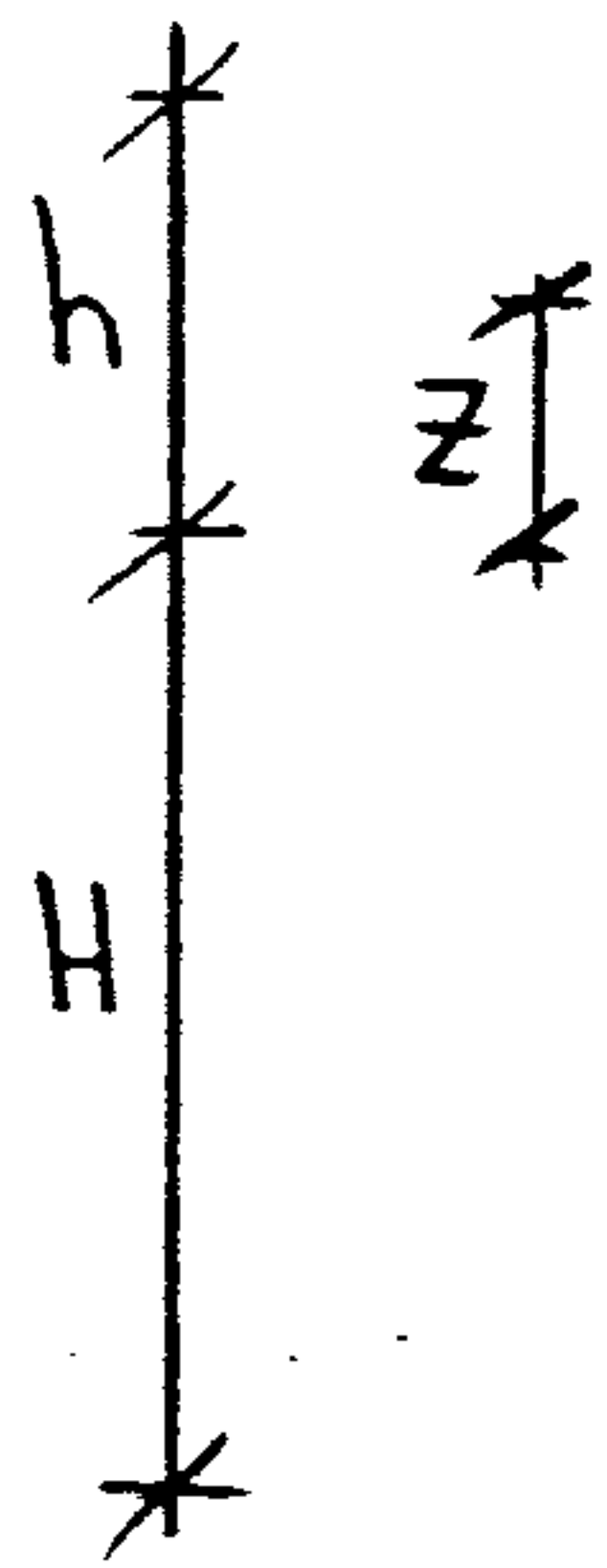

If  $z < h$  case (a) no liquid is spilled

If  $z = h$  case (b) liquid at the point of spilling

If  $z > h$  Water is spilled ⇒ 3 cases

# How to get $(a_x)_{max}$ or max height of the Container

## to make the liquid at the spilling point

$$\tan\theta = \frac{a_{x_{max}}}{g \pm a_z} = \frac{h}{L/2}$$

⇒ get  $a_{x_{max}}$

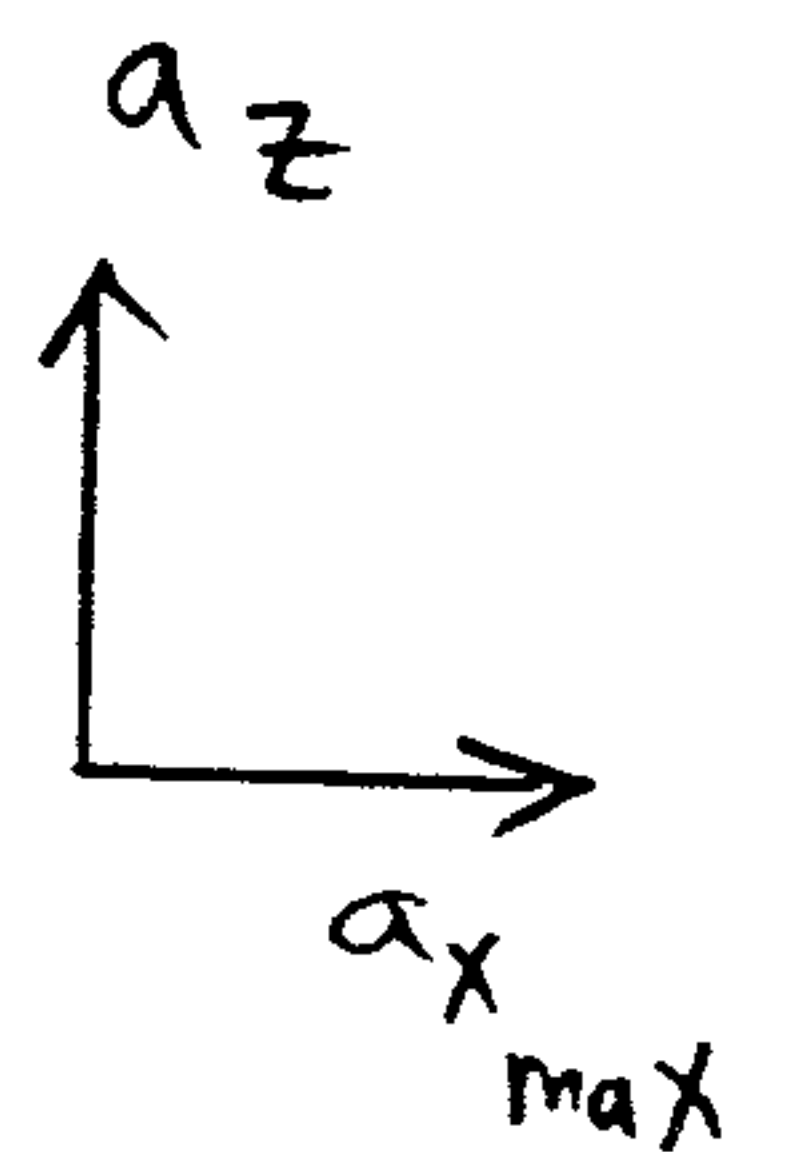
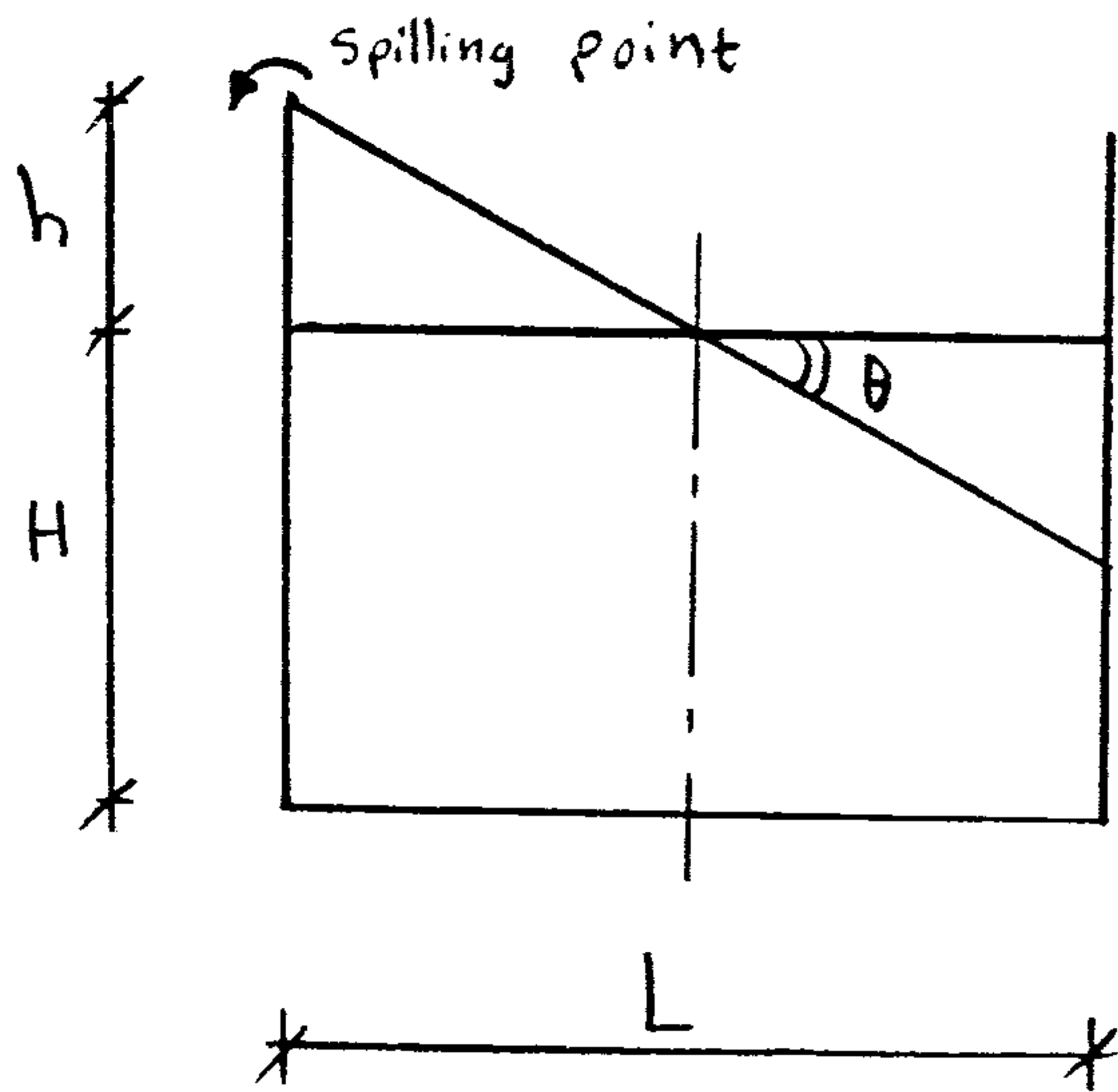

$$\tan\theta = \frac{a_x}{g \pm a_z} = \frac{h_{max}}{L/2}$$

⇒ get  $h_{max}$



When is liquid spilled?

IF  $z > h$       Liquid is spilled }  
 or IF  $a_x > a_{x_{max}}$       " " "      } 3 Cases

$$\tan \theta = \frac{a_x}{g \pm a_z} = \frac{y}{L}$$

⇒ get y

IF  $y < H+h$  ⇒ Case 1

IF  $y = H+h$  ⇒ Case 2

IF  $y > H+h$  ⇒ Case 3

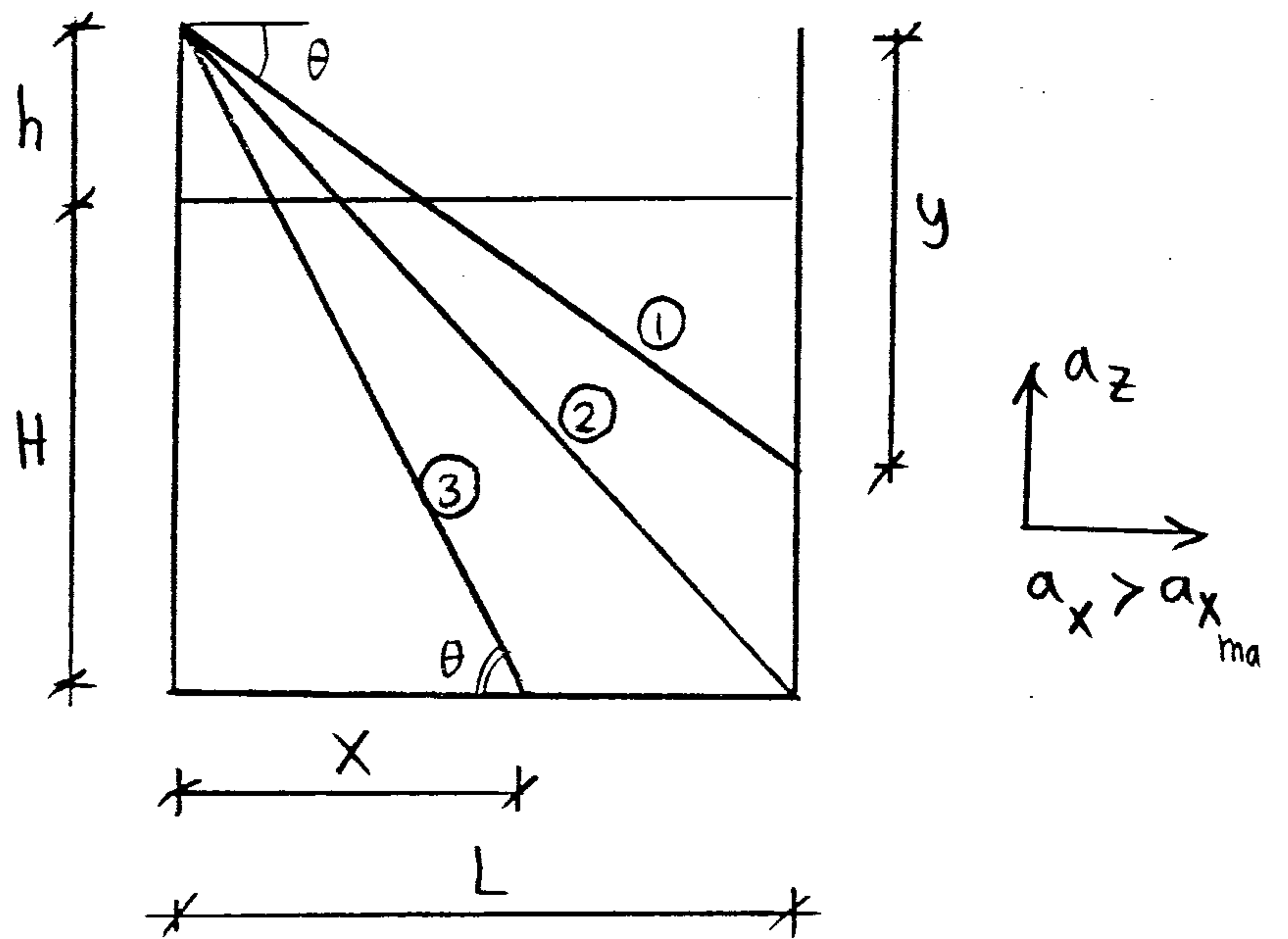

Case 3  $\tan \theta = \frac{a_x}{g \pm a_z} = \frac{H+h}{x}$

⇒ get x

How to get the Volume of spilled water?

for case ①, ②

Volume spilled = Volume of air after motion - Volume of air before motion

$$V_{spilled} = \left[ \frac{1}{2} Ly - Lh \right] b$$

Case ③

Volume spilled = Volume of water before motion - Volume of water after motion

$$V_{spilled} = \left[ LH - \frac{1}{2} x (H+h) \right] b$$

Case of closed tank, find Pressure at (1) and (2)

$$\tan \theta = \frac{a_x}{g \pm a_z} = \checkmark$$

$$\tan \theta = \frac{y}{x} \rightarrow \textcircled{1}$$

∴ Area of air before motion = Area of air after motion

$$Lh = \frac{1}{2}xy \rightarrow \textcircled{2}$$

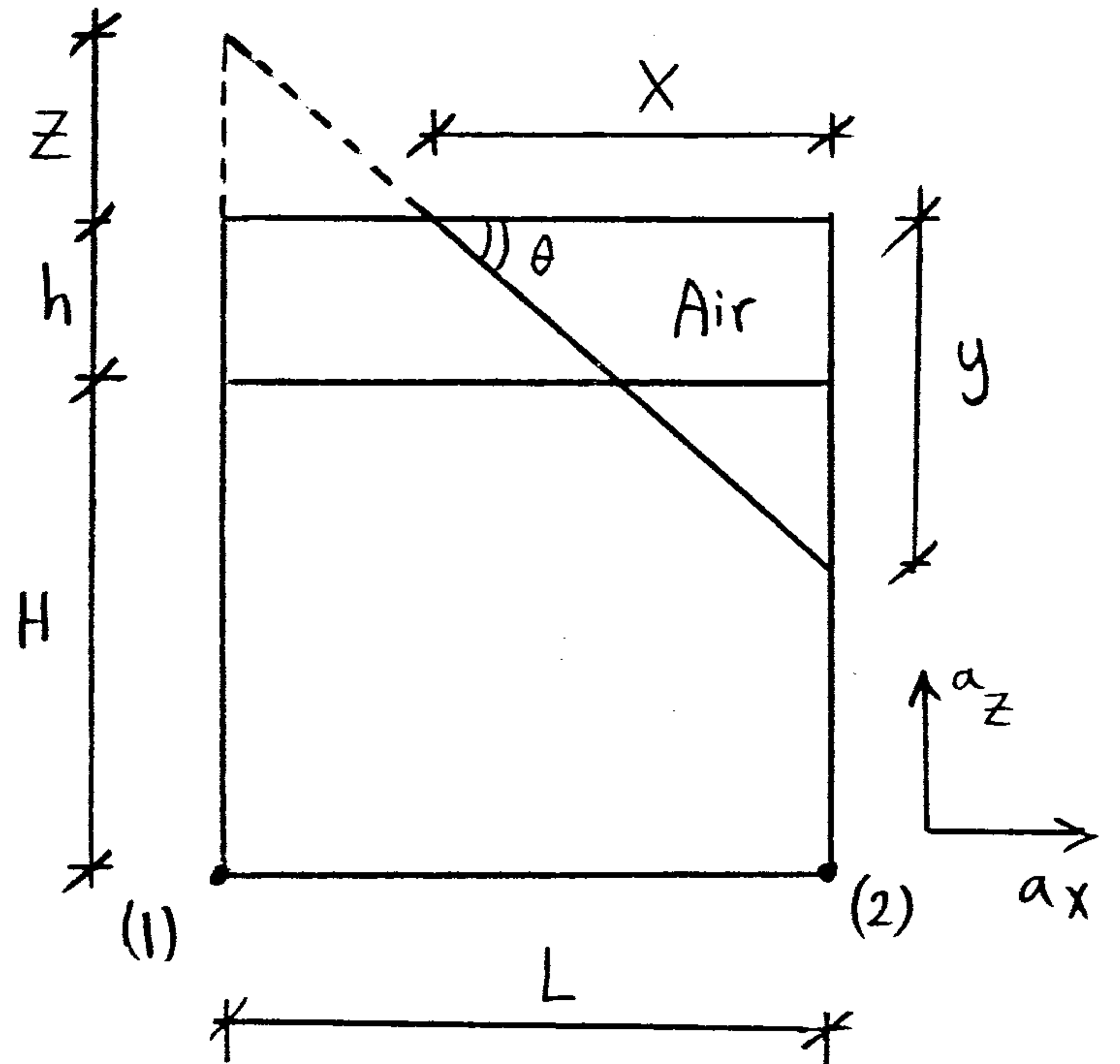

from ①, ② ⇒ get x, y

⇒ get z *حساب میات*

$$P_1 = P_{air} + \frac{\gamma}{g} (g \pm a_z) [H + h + z]$$

$$P_2 = P_{air} + \frac{\gamma}{g} (g \pm a_z) [H + h - y]$$

Forces on tank sides during acceleration

$$F = \gamma' A \bar{h}$$

$$\gamma' = \frac{\gamma}{g} (g \pm a_z)$$

A = area of side view

$$\bar{h} = \frac{h}{2}$$

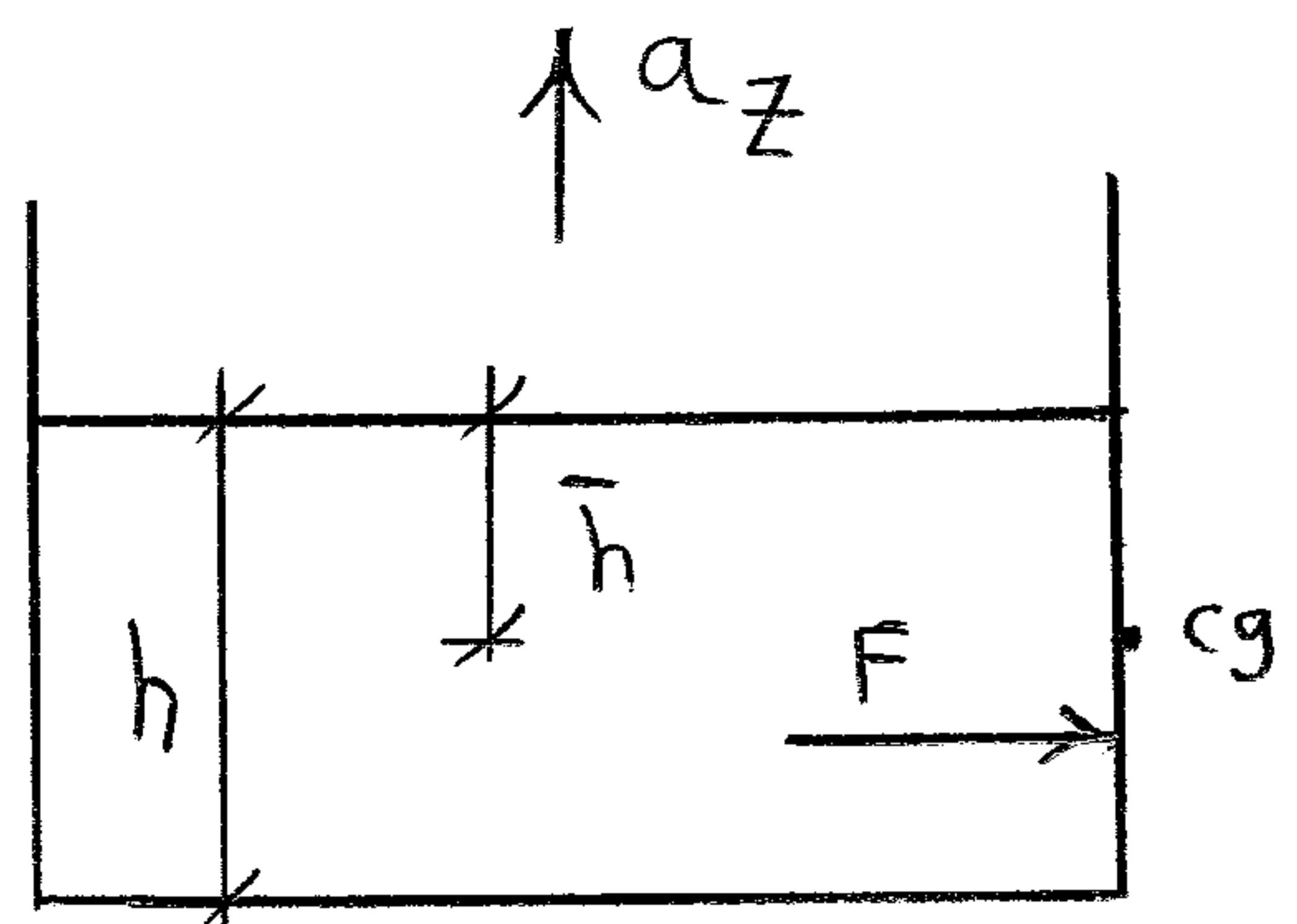

Apply the basic hydrostatics equation to determine the pressure variation in the horizontal and vertical directions and the slope of the surface of constant pressure for any body fluid in rigid body motion.

### Fluid Masses Subjected to linear Acceleration

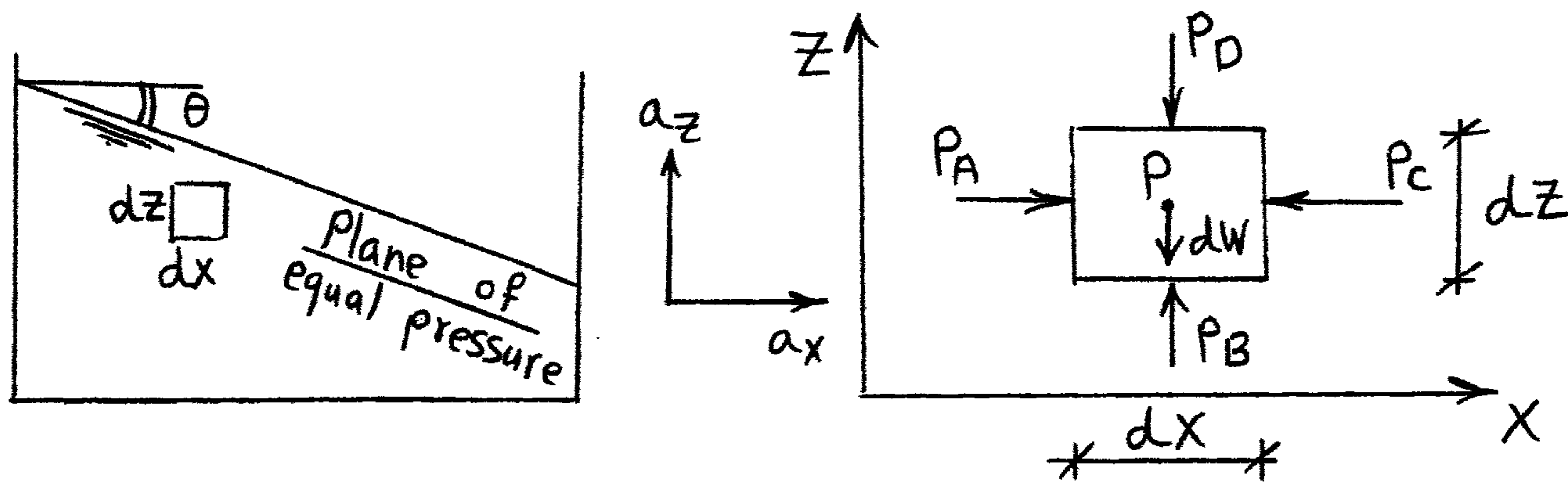

Consider a Small fluid element with dimensions (dx dz)

$$\Sigma F_x = P_A dz - P_c dz \dots\dots ①$$

$$\Sigma F_z = P_B dx - P_D dx - dW \dots\dots ②$$

$$\left. \begin{aligned} P_A &= P - \frac{\partial P}{\partial x} \frac{dx}{2} & , & & P_c &= P + \frac{\partial P}{\partial x} \cdot \frac{dx}{2} \\ P_B &= P - \frac{\partial P}{\partial z} \frac{dz}{2} & , & & P_D &= P + \frac{\partial P}{\partial z} \cdot \frac{dz}{2} \end{aligned} \right\} \rightarrow ③$$

$$\Sigma F_x = dM a_x \rightarrow ④$$

$$P_A dz - P_c dz = dM a_x$$

$$\left( P - \frac{\partial P}{\partial x} \cdot \frac{dx}{2} \right) dz - \left( P + \frac{\partial P}{\partial x} \cdot \frac{dx}{2} \right) dz = \frac{\gamma}{g} dx dz a_x$$

$$-\frac{\partial P}{\partial x} dx = \frac{\gamma}{g} dx a_x$$

⑧

$$\boxed{\frac{\partial P}{\partial x} = -\frac{\gamma}{g} a_x} \rightarrow \textcircled{5}$$

$$\Sigma F_z = dM a_z \rightarrow \textcircled{6}$$

$$P_B dx - P_D dx - dW = dM a_z$$

$$\left(P - \frac{\partial P}{\partial z} \frac{dz}{2}\right) dx - \left(P + \frac{\partial P}{\partial z} \cdot \frac{dz}{2}\right) dx - \gamma dx dz = \frac{\gamma}{g} dx dz a_z$$

$$-\frac{\partial P}{\partial z} \cdot dz - \gamma dz = \frac{\gamma}{g} dz a_z$$

$$\boxed{\frac{\partial P}{\partial z} = -\frac{\gamma}{g} (g + a_z)} \rightarrow \textcircled{7}$$

$$dP = \frac{\partial P}{\partial x} dx + \frac{\partial P}{\partial z} dz = 0 \rightarrow \textcircled{8}$$

$$\frac{dz}{dx} = \frac{-\partial P / \partial x}{\partial P / \partial z}$$

$$\boxed{\tan \theta = \frac{dz}{dx} = \frac{-a_x}{g \pm a_z}} \rightarrow \textcircled{9}$$

# Uniform Rotation about Vertical Axis (14)

$$\omega = \frac{2\pi N}{60}$$

$N$  = Number of revolutions  
Per minute (r.p.m.)

$\omega$  = Angular velocity

$$y = \frac{\omega^2 x^2}{2g}$$

$$h = \frac{\omega^2 r^2}{2g}$$

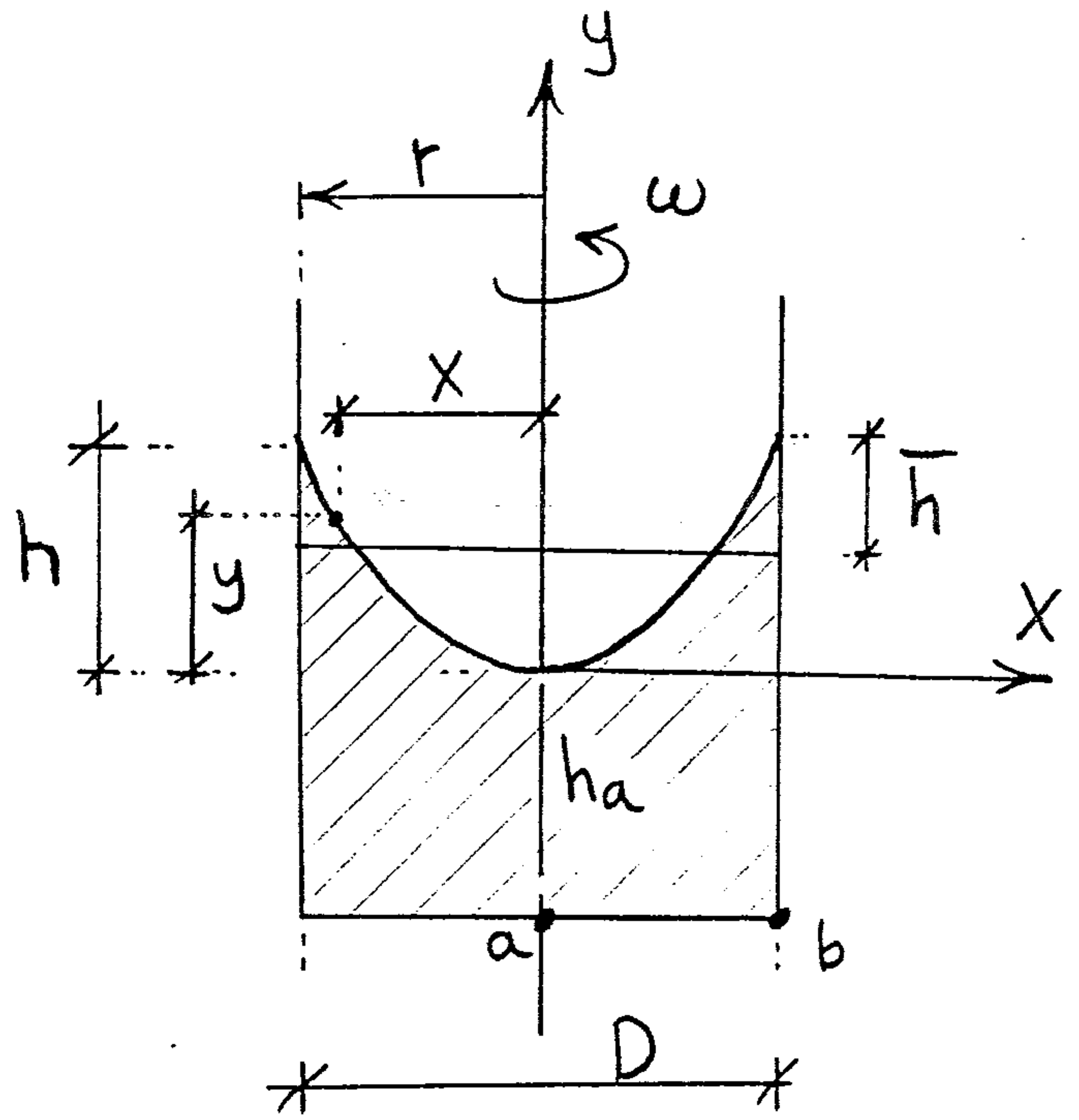

في حالة عدم الانكاب

حجم السائل قبل الدوران = حجم السائل بعد الدوران

حجم الفراغ قبل الدوران = حجم الفراغ بعد الدوران

حجم ال Paraboloid يساوي  $\frac{1}{2}$  حجم الاسطوانة المشتركة معه في القاعدة والارتفاع

$$V_{\text{parab}} = \frac{1}{2} \pi r^2 h$$

في حالة عدم الانكاب يتم ال Paraboloid الى ارتفاعين متساويين

If No liquid is spilled

Volume of air before rotation = Volume of air after rotation

$$\pi r^2 \bar{h} = \frac{1}{2} \pi r^2 h$$

$$\Rightarrow \bar{h} = \frac{h}{2}$$

Open Tank Cases

(15)

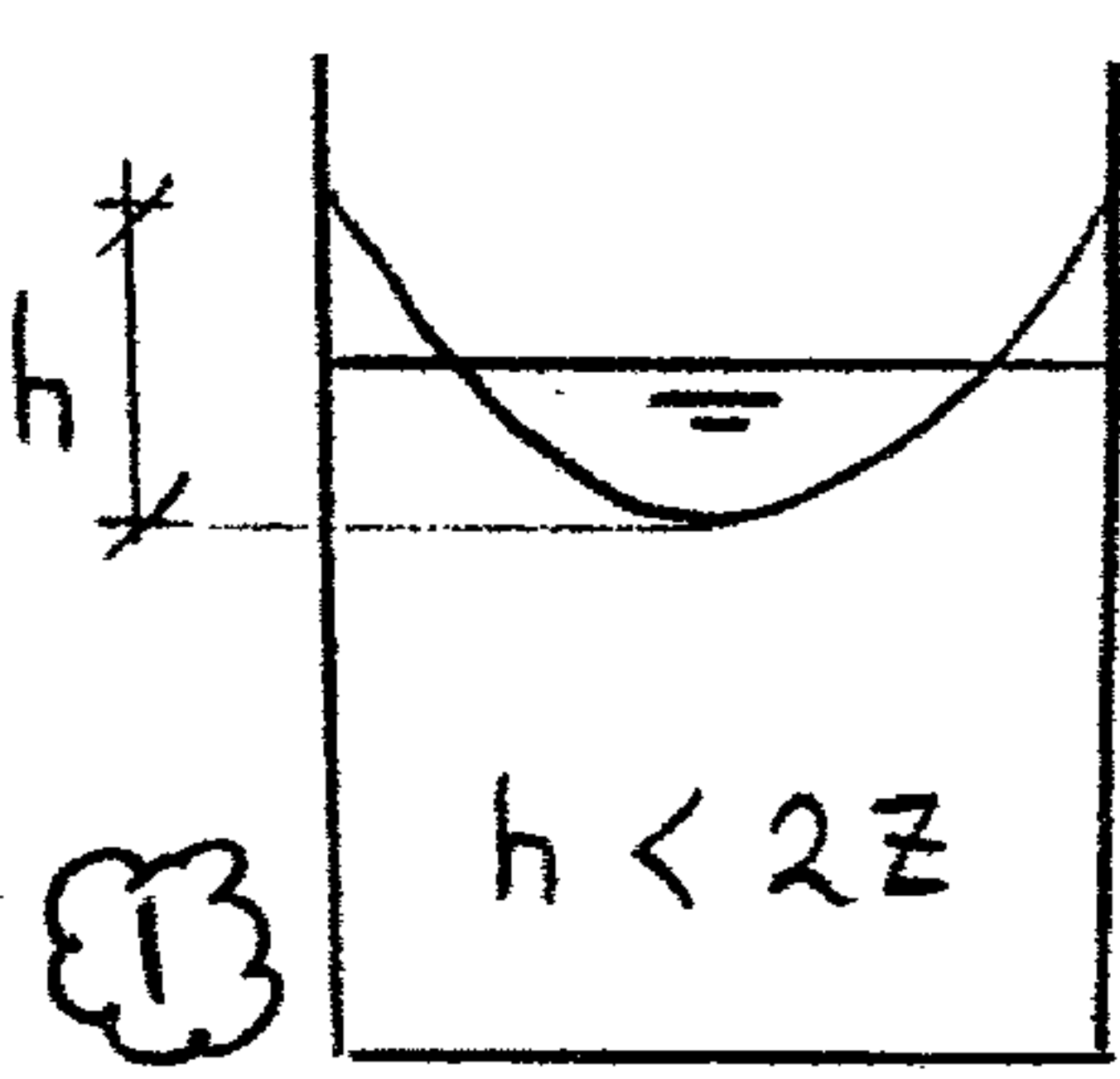

No spilling

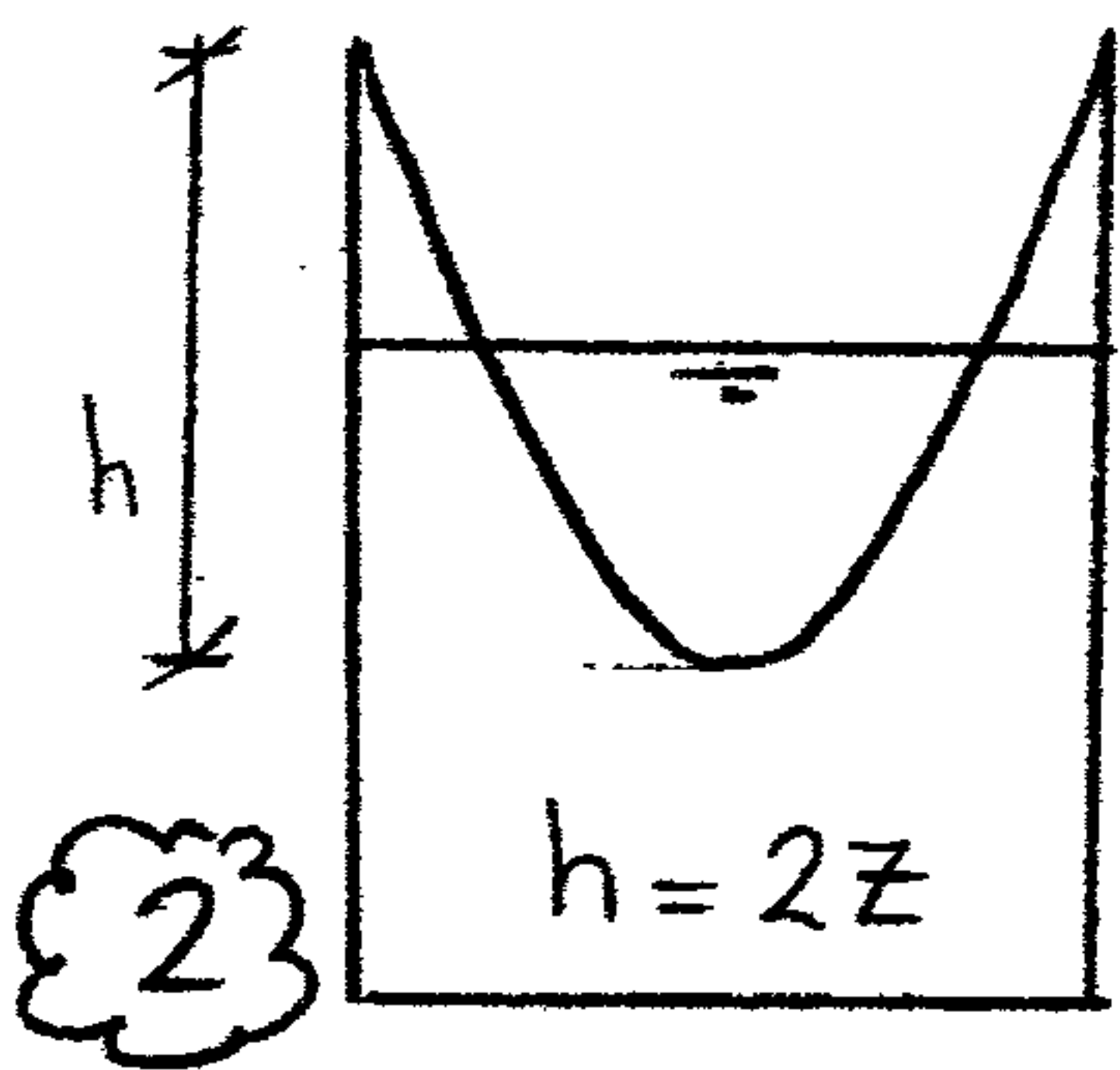

No spilling  
(at the point of spilling)

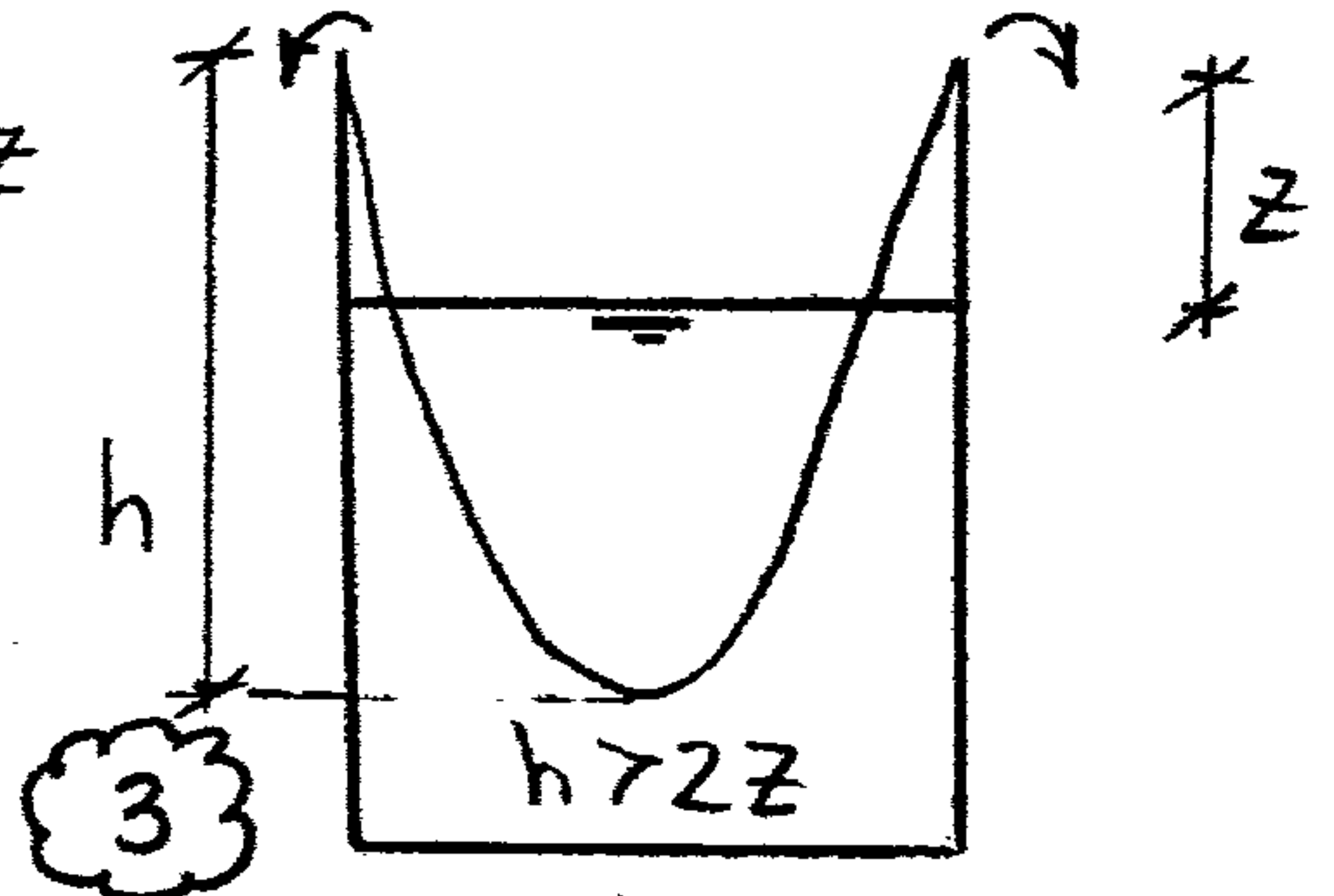

spilling

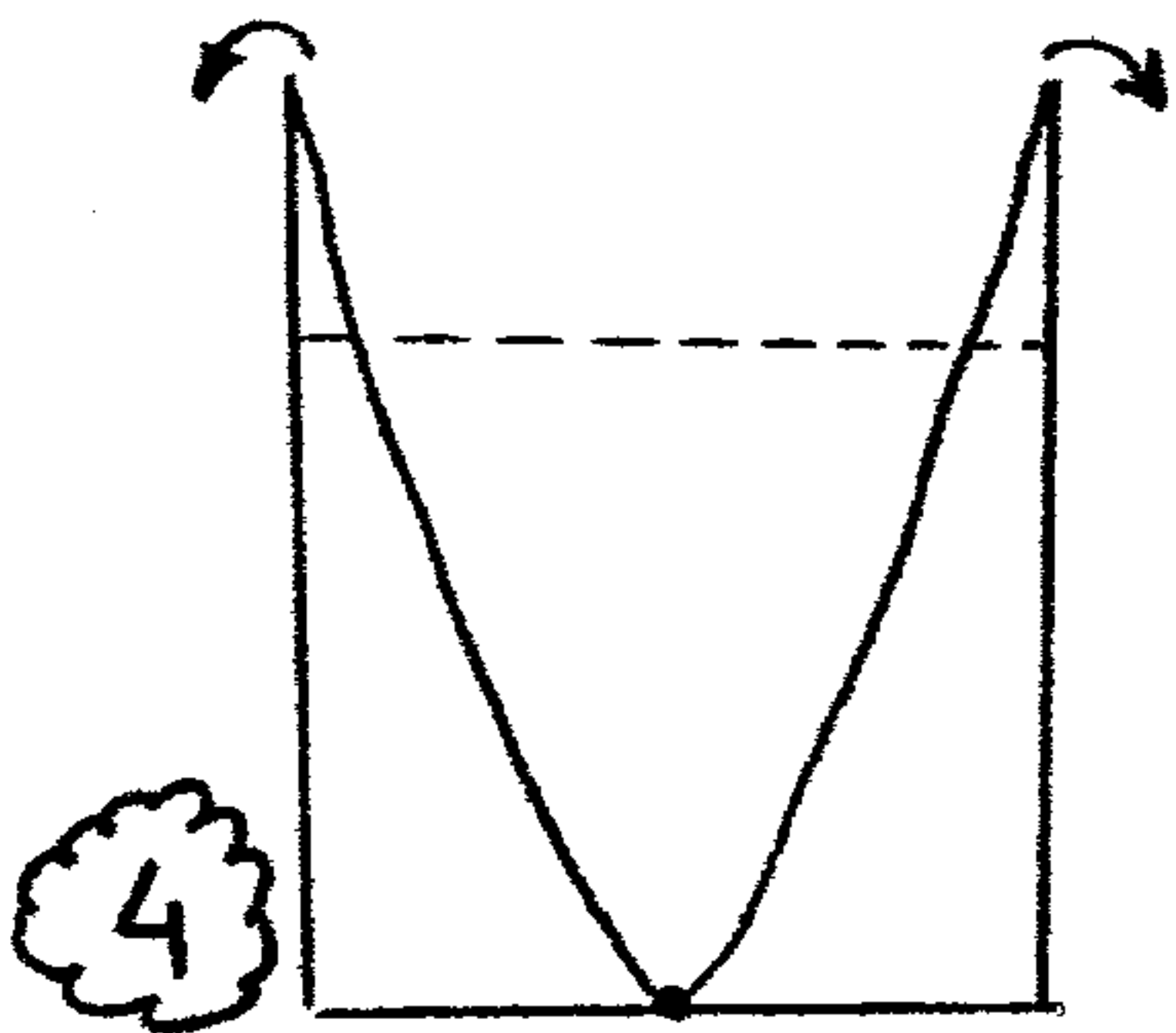

Point at the center  
is just uncovered

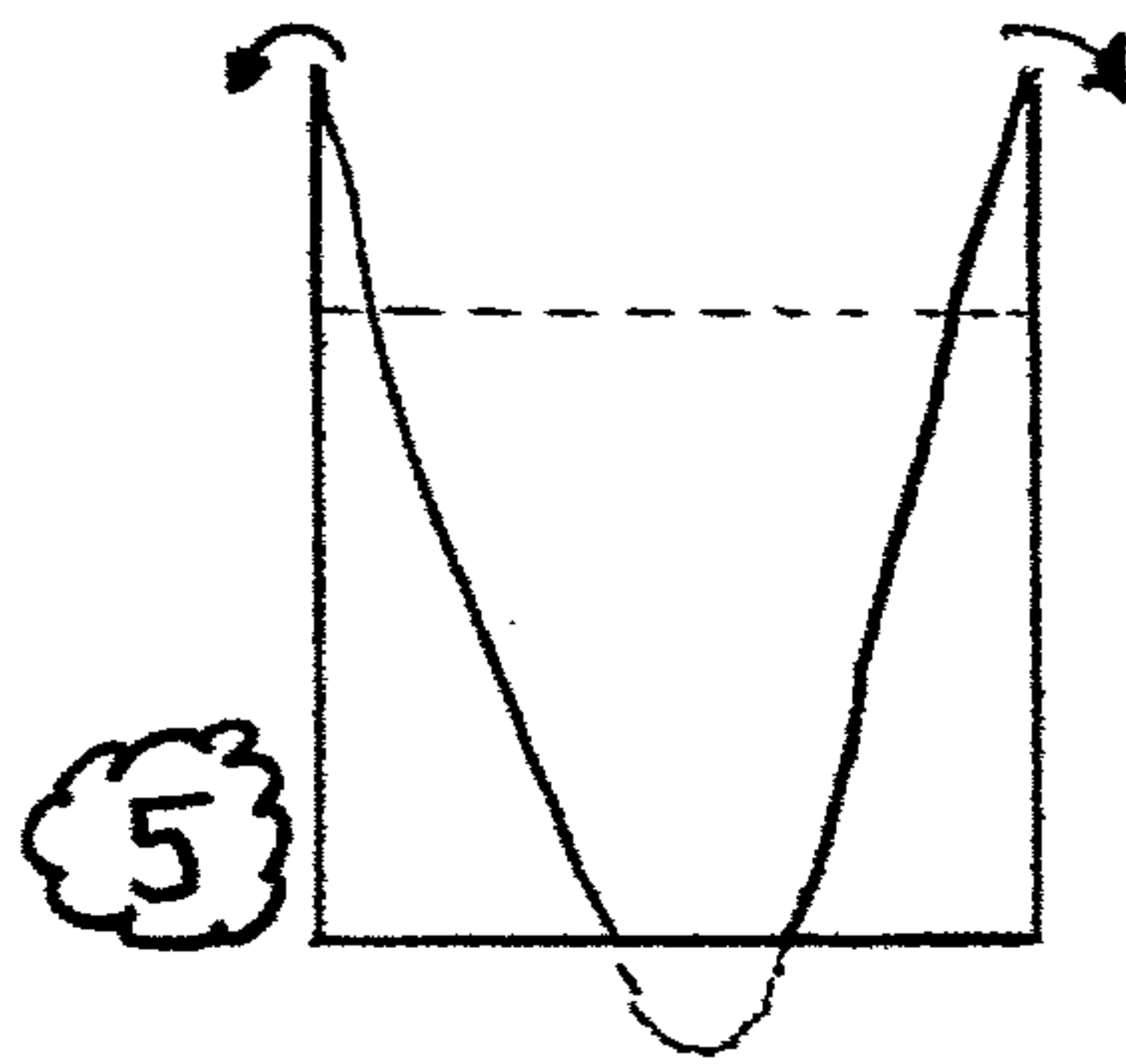

bottom of the tank  
is uncovered

Closed Tank Cases

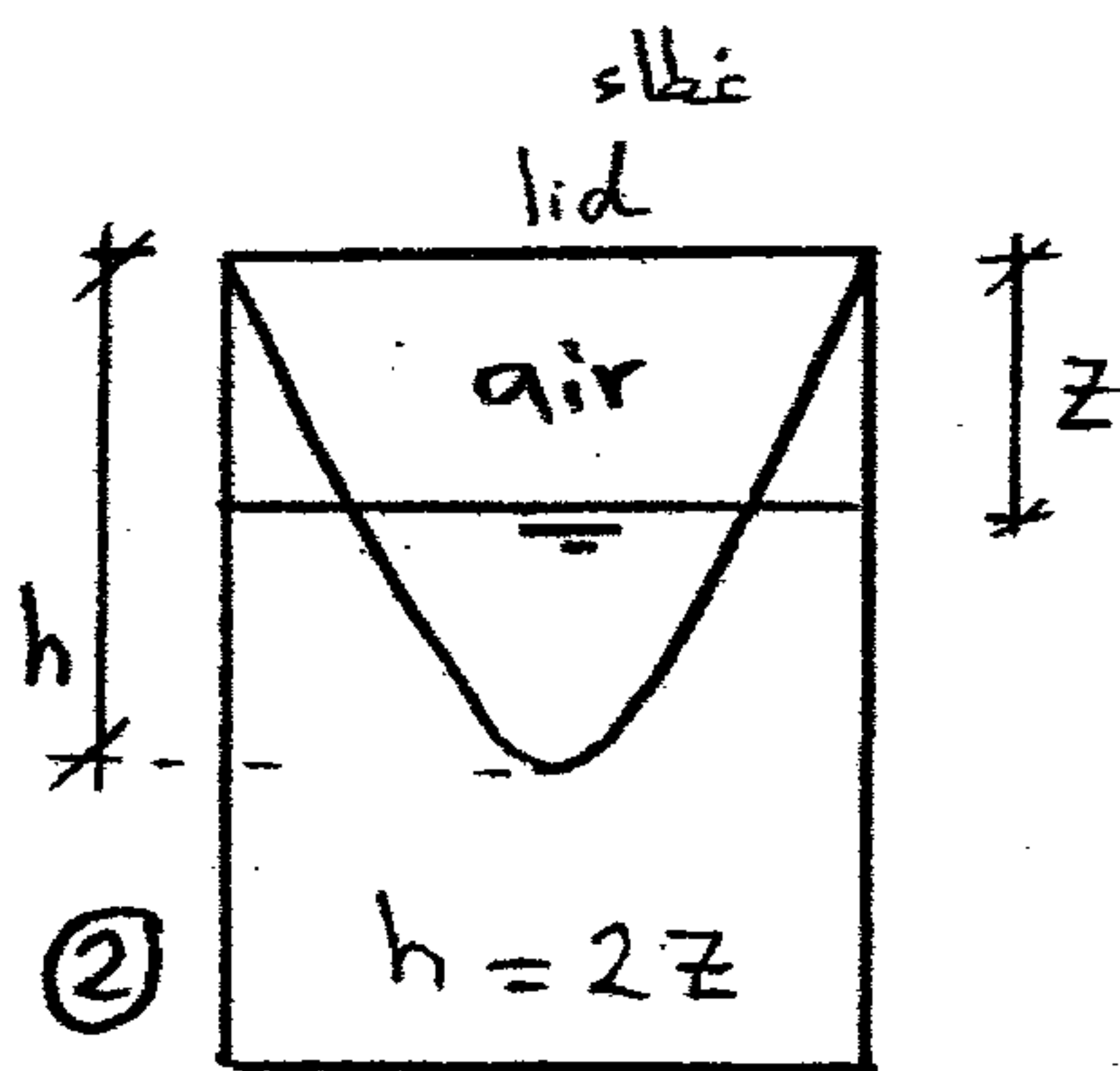
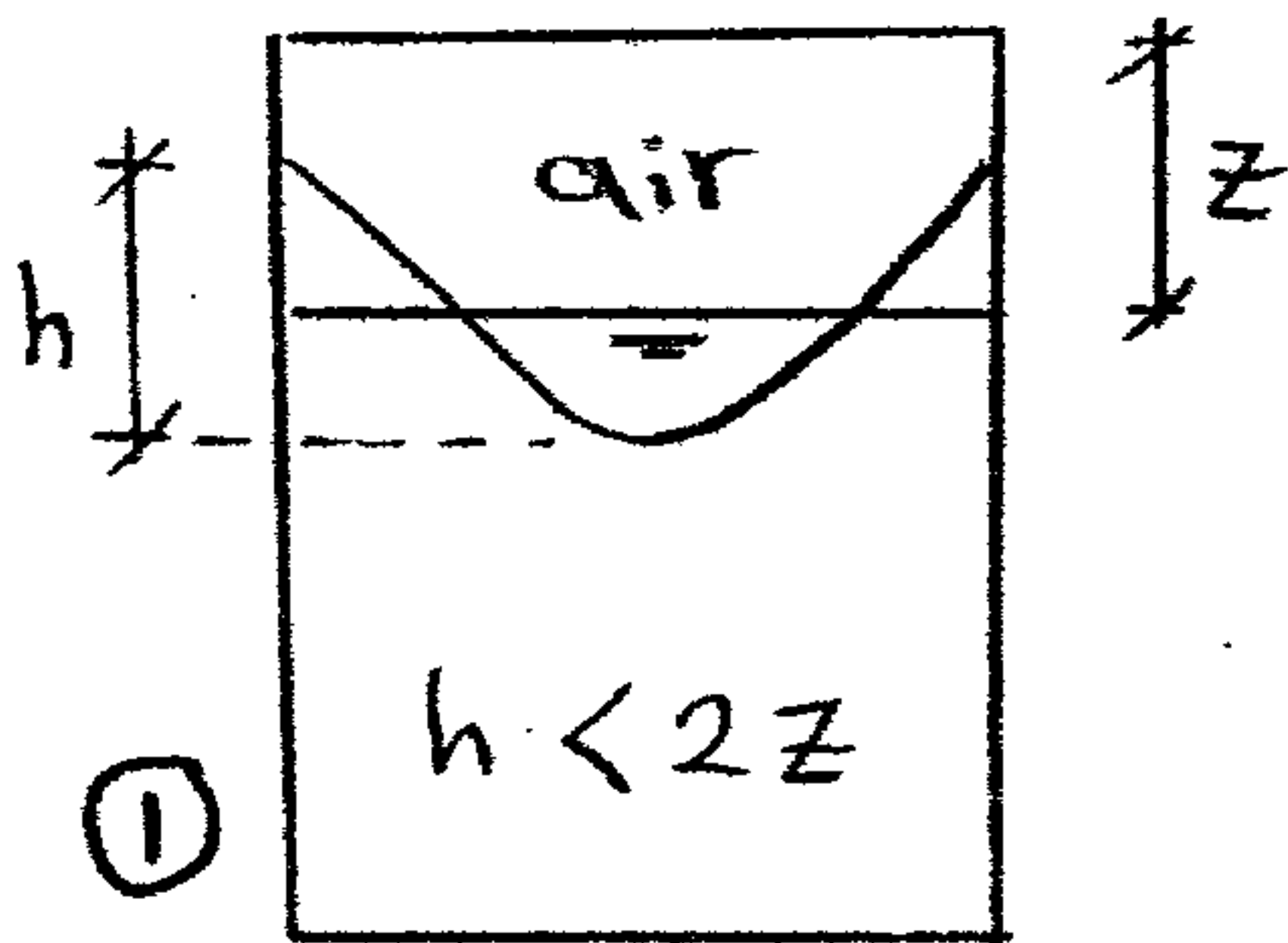

Water starts to  
touch the lid

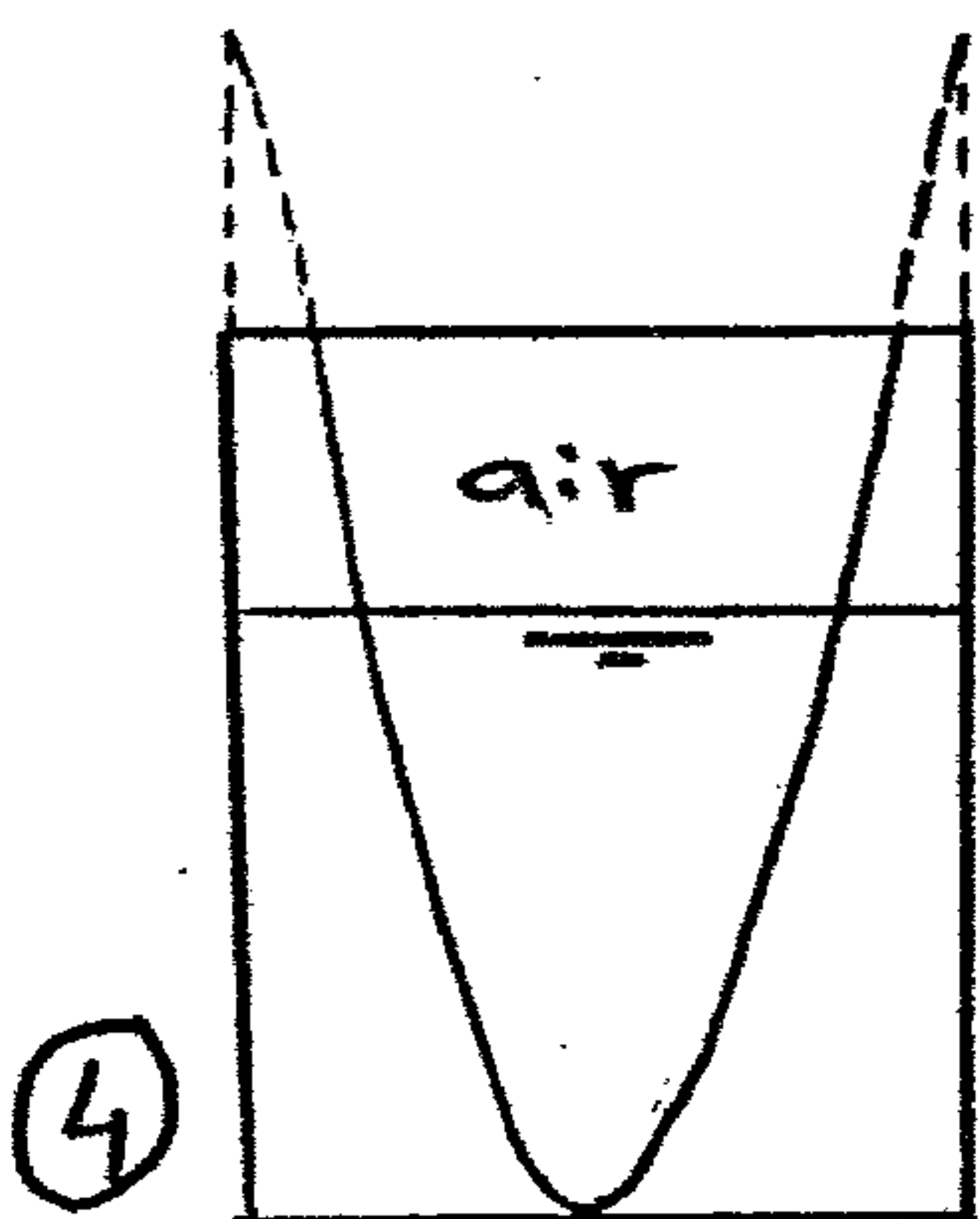
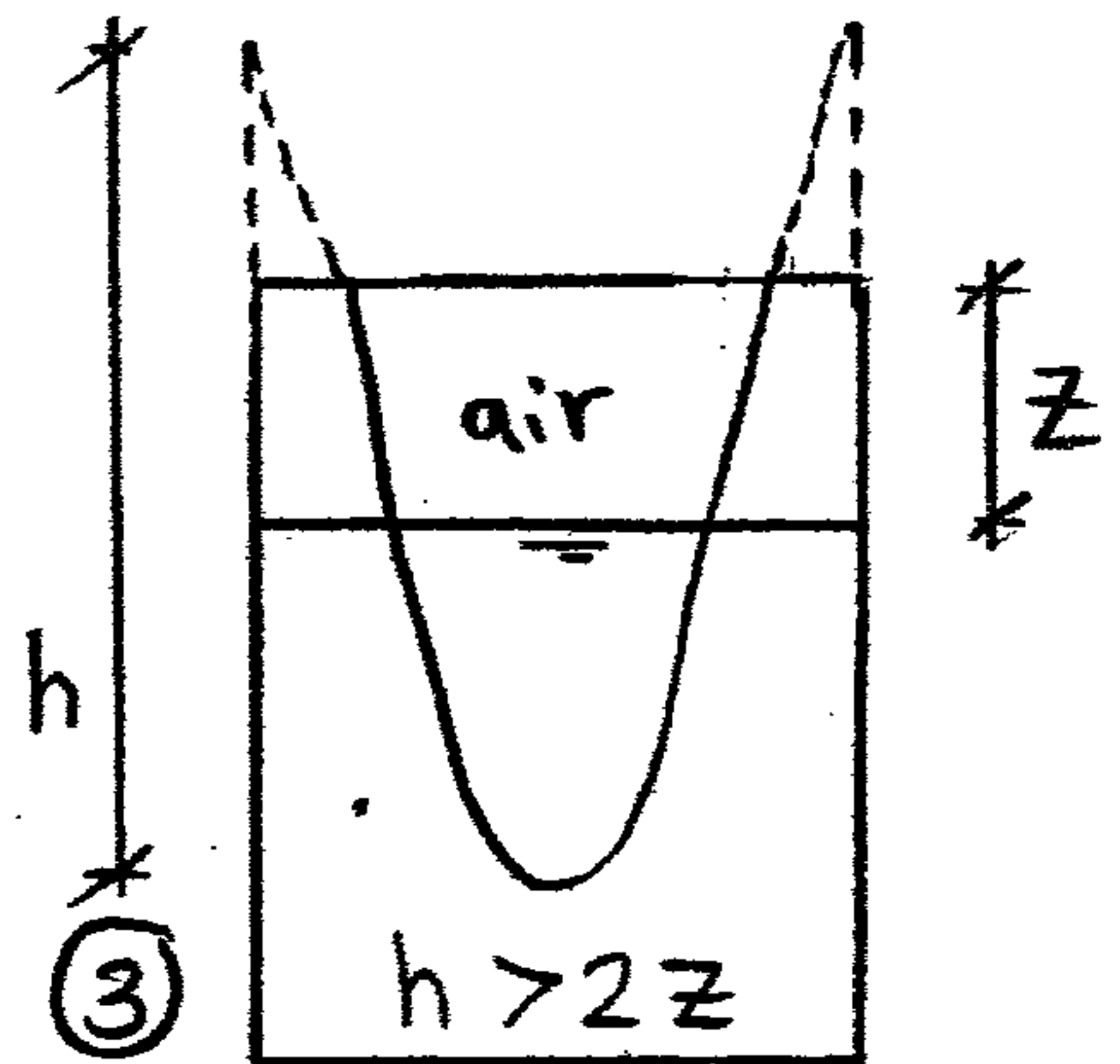

Point at the center  
is just uncovered

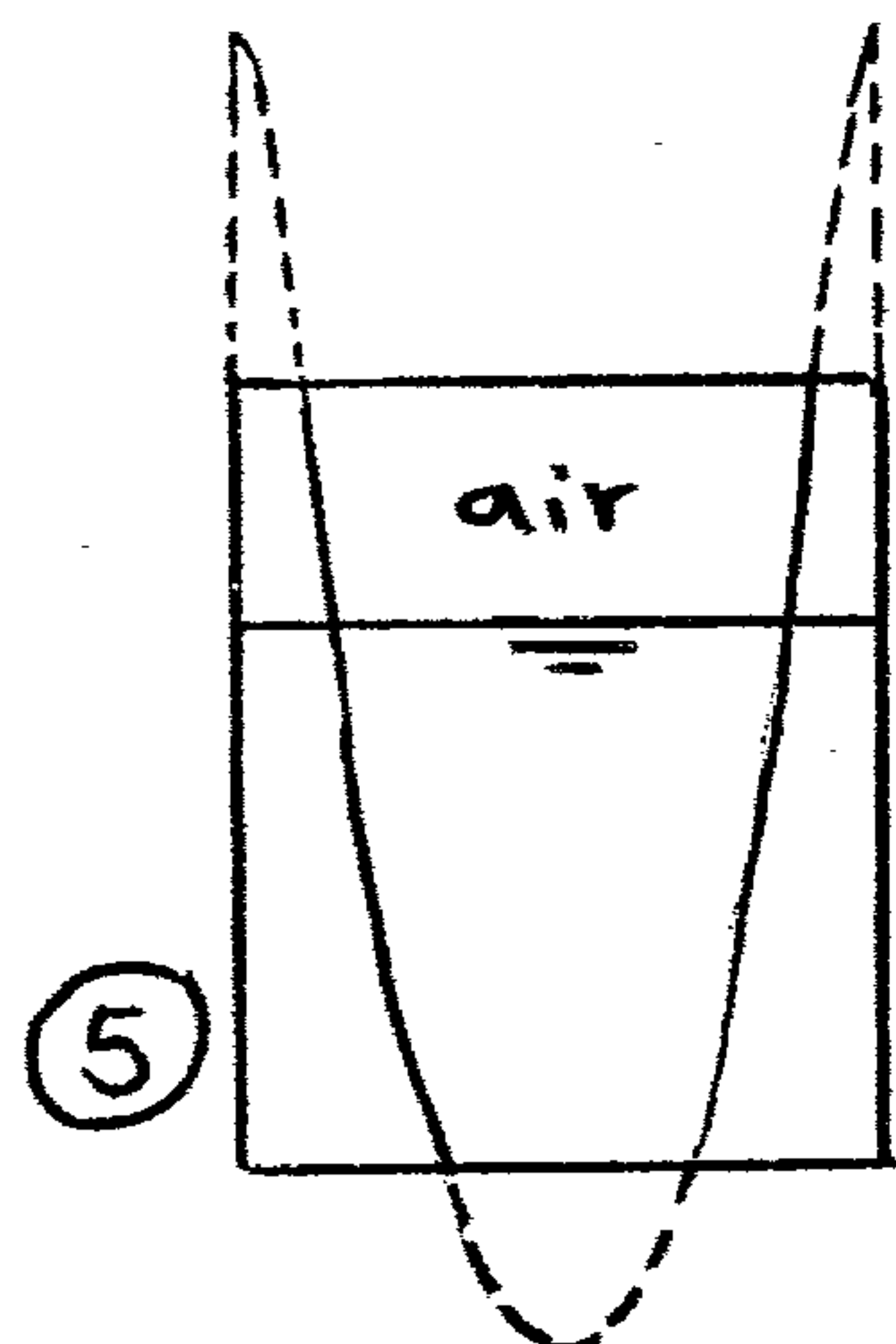

bottom of the tank  
is uncovered

# 7

①

## Buoyancy & Floatation

### Archimedes principle

Any weight, floating or submerged in a liquid, is acted upon by a **buoyant force** equal to the weight of the liquid displaced, and acts through the center of gravity of the displaced liquid.

$$\therefore \text{Weight of floating body} = \text{Weight of liquid displaced}$$

$$\gamma_b V_b = \gamma_w V_{sub}$$

$$\text{s.g. } \gamma_w L b d = \gamma_w L b h_{sub}$$

$$\therefore h_{sub} = \text{s.g. } d \quad (\text{in this example})$$

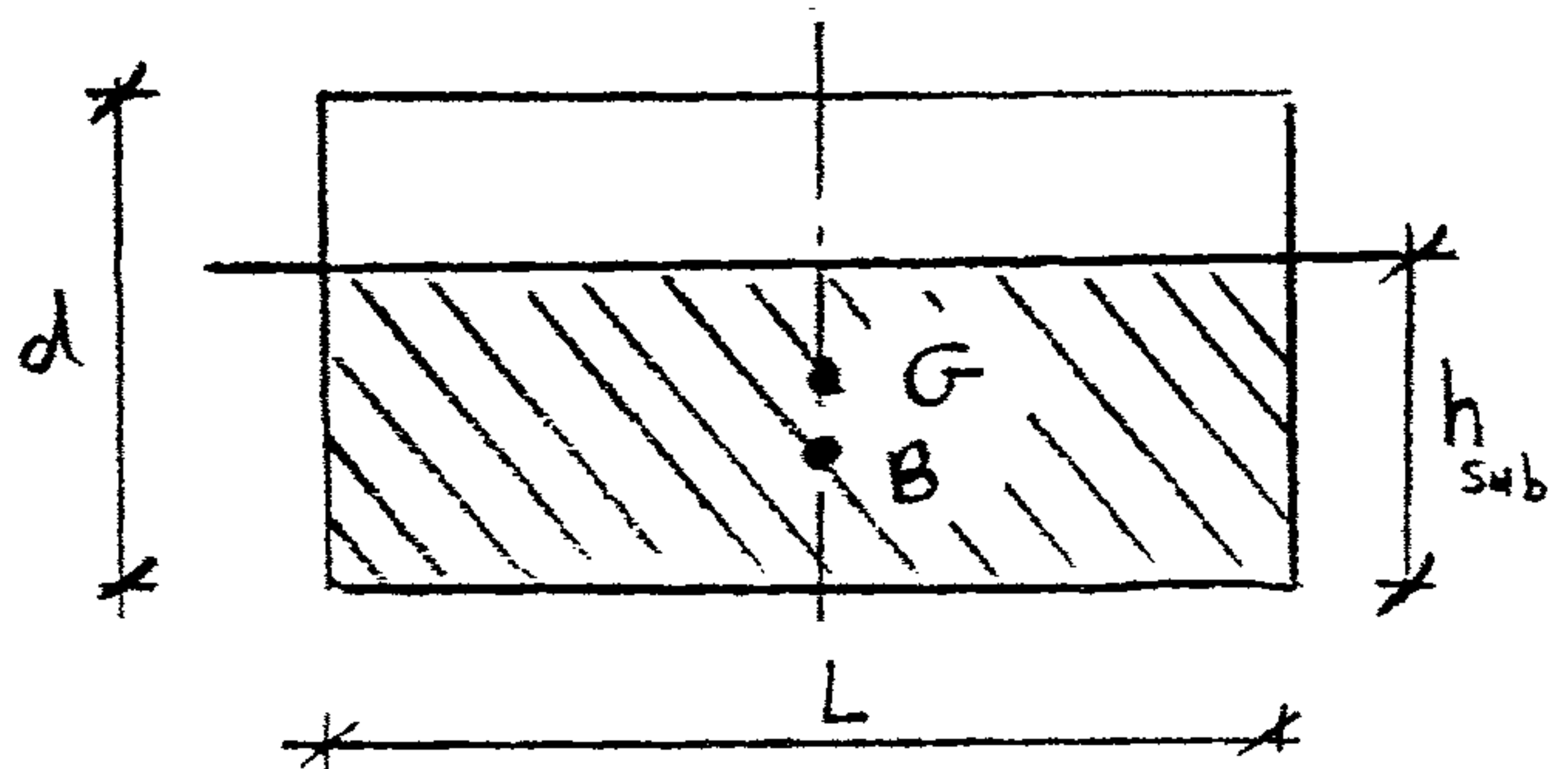

Center of Gravity (G) = Centroid of the whole body

Center of Buoyancy (B) = Centroid of the displaced liquid

### Rotational stability of floating bodies

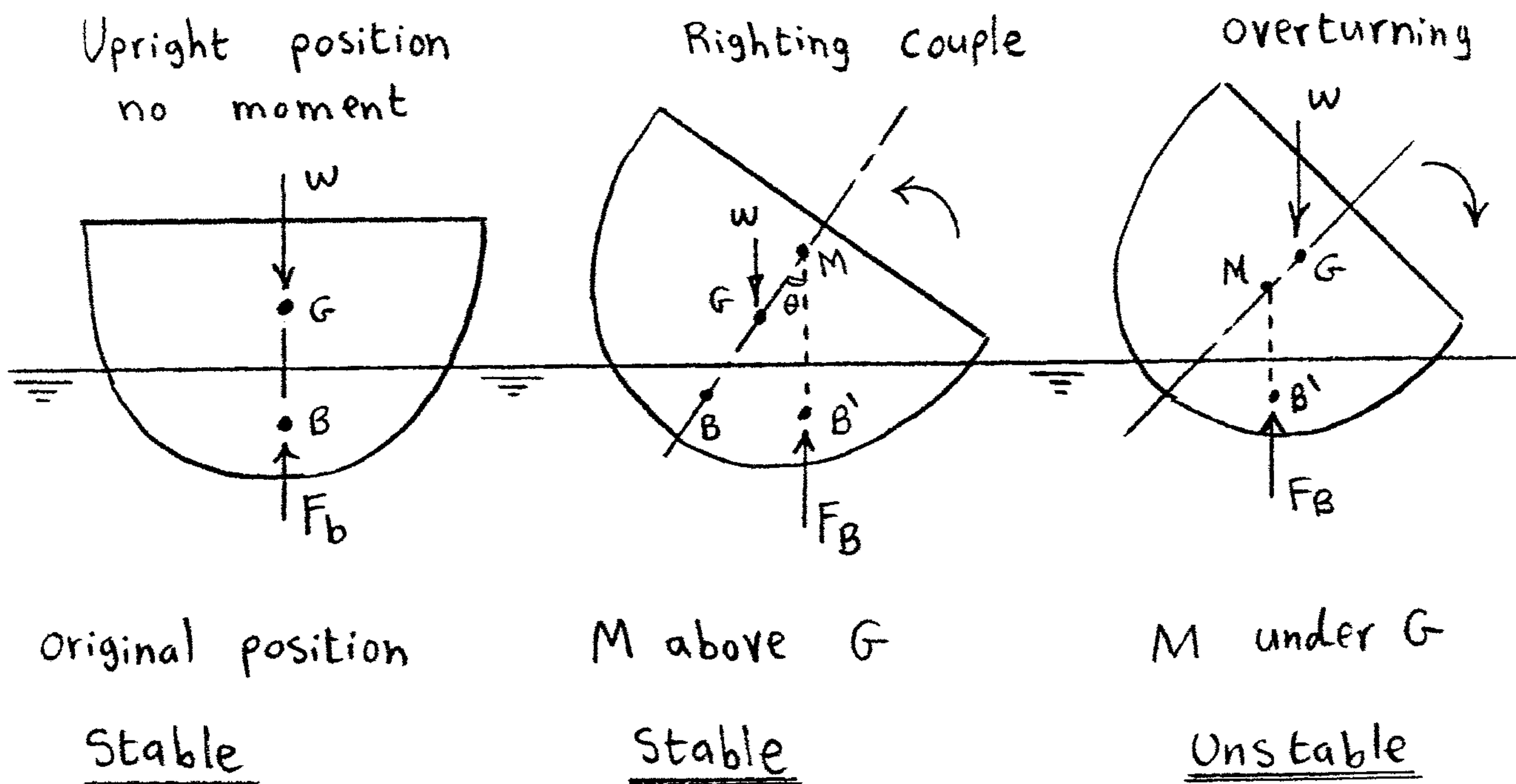

- \* When the body is upright, point G and B lie on the same vertical  
 $\Rightarrow$  no moment
- \* When the body is slightly rotated through a small angle  $\theta$  the shape of the displaced volume gets different with an increase of volume towards one side.  
 $\Rightarrow$  the centroid of the displaced volume B changes to B'
- \* Let a vertical through B' intersect the centerline at M
- \* The line of action of the buoyant force (acting through B') forms a righting couple to return the body to its original position.  
 $\Rightarrow$  the body is stable when point M is above G
- \* The point (M) is called the *metacenter*.

$$GM = BM - BG$$

GM = metacentric height  
 = +ve      stable  
 = -ve      unstable

where

$$BM = \frac{I_y}{V_{sub}}$$

$I_y$  = Moment of inertia around axis of rotation

$V_{sub}$  = Submerged Volume

BG = distance between B and G

$$BG = \frac{d}{2} - \frac{h_{sub}}{2}$$

(in this example)

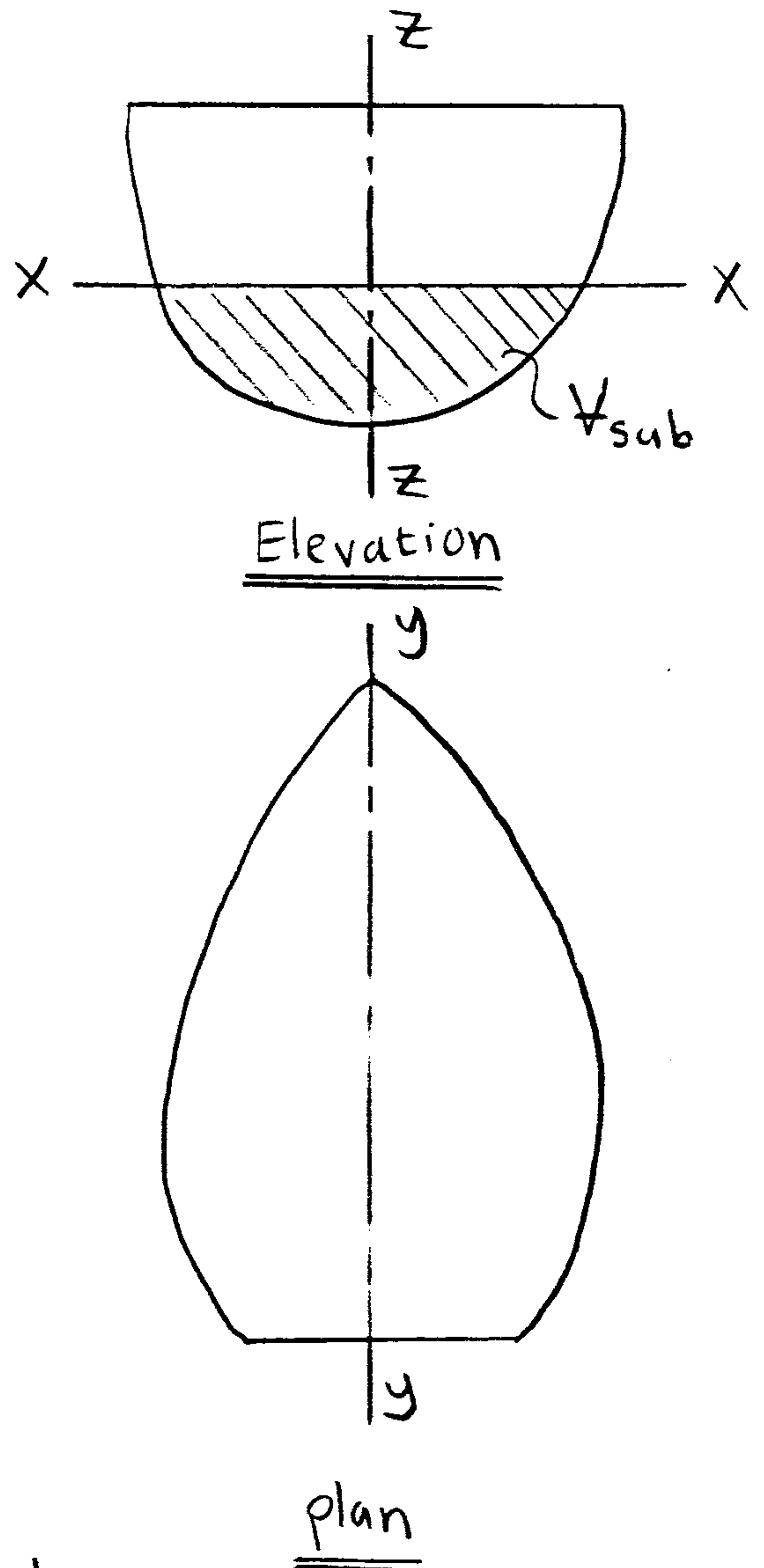



## Center of Buoyancy

- It is the point of application of the force of buoyancy on the body.
- It is always the center of gravity of the volume of fluid displaced.

## Types of equilibrium of Floating bodies

1. Stable equilibrium,
2. Unstable equilibrium and
3. Neutral equilibrium.

### Stable Equilibrium

- It occurs when a body is tilted slightly by some external force, and then it returns back to its original position due to the weight and the upthrust.
- The position of metacentre M is higher than the center of gravity G.

### Unstable Equilibrium

- It occurs when a body does not return to its original position from the slightly displaced angular position.
- The position of metacentre M is lower than G.

### Neutral Equilibrium

- It occurs when a body, when given a small angular displacement, occupies a new position and remains at rest.
- The position of metacentre M coincides with G.

الرسم ضروري مع كل تعريف

### Metacentre

- The metacentre is the point of intersection of the axis of the body passing through the center of gravity (G) with the original centre of buoyancy (B) and a vertical line passing through the centre of buoyancy (B') of the tilted position of the body.
- The position of metacentre (M) remains practically constant for the small angle of tilt  $\theta$ .

### Metacentric Height:

- It is the distance between the centre of gravity of a floating body and the metacentre.
- $GM = BM - BG$

# 8

①

## Fundamentals of Fluid Flow

### Types of fluid flow

#### 1- Steady and unsteady flow

##### a- Steady flow

It occurs when velocity, acceleration,.. etc doesn't change with time

$$\frac{dV}{dt} = 0$$

##### b- Unsteady flow

It occurs when velocity or acceleration,.. etc changes with time

e.g. flow in a pipe whose valve is opening or closing

$$\frac{dV}{dt} \neq 0$$

#### 2-Uniform and Non-uniform flow

##### a- Uniform flow

It occurs when velocity and cross-section remains constant over a given length

$$\frac{dV}{dL} = 0, \quad \frac{dA}{dL} = 0$$

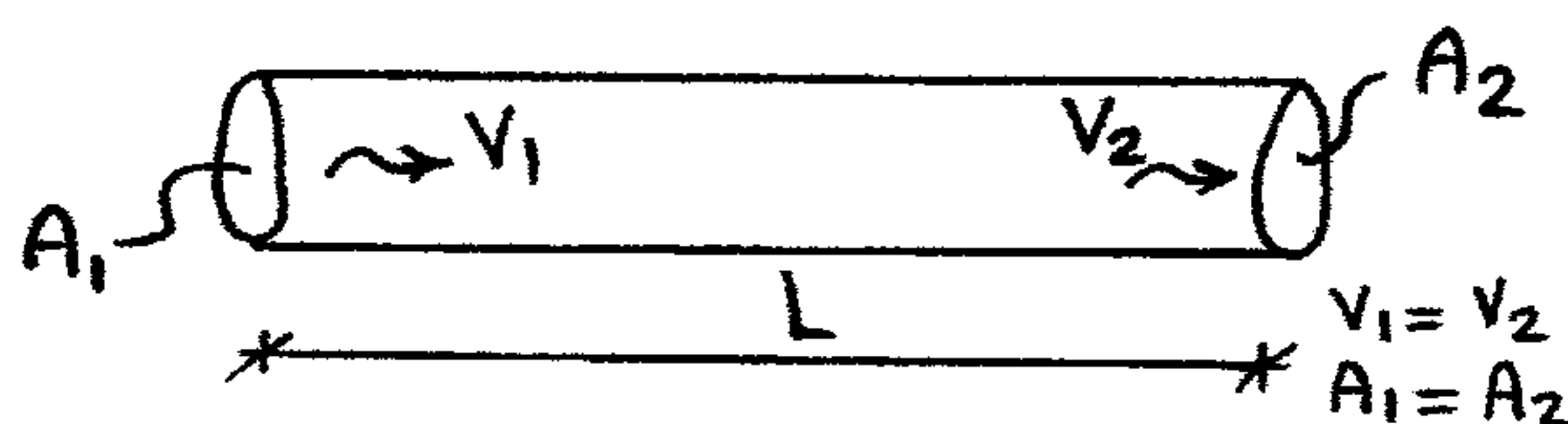

##### b- Non-uniform flow

It occurs when velocity or cross-section changes over a given length

$$\frac{dV}{dL} \neq 0, \quad \frac{dA}{dL} \neq 0$$

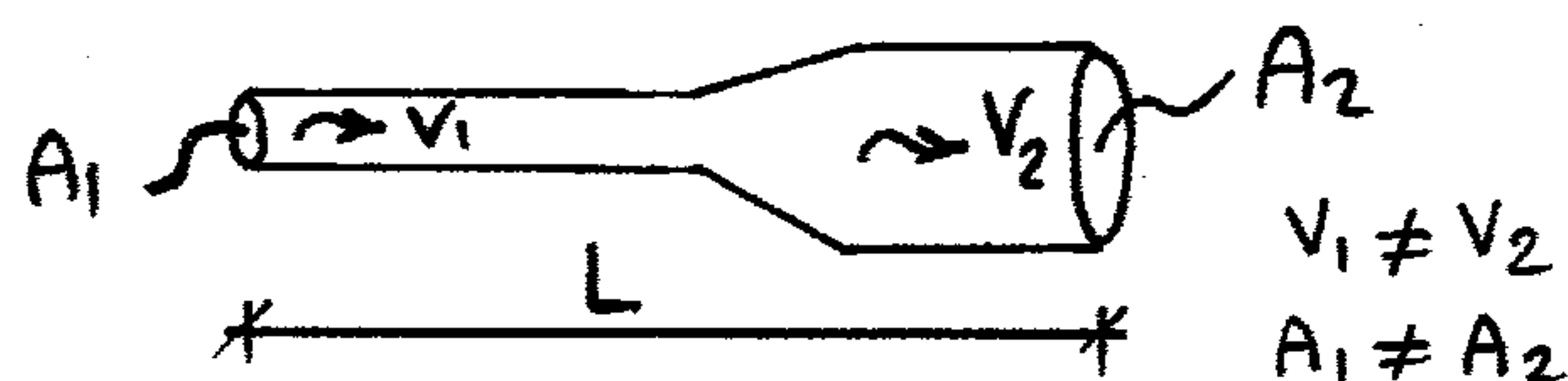

### 3- Laminar and turbulent flow

#### **a- Laminar flow**

It occurs when fluid particles in parallel paths and do not intersect

*e.g.* flow through capillary tubes, ground

water, and blood in veins.

$$R_n < 2000$$

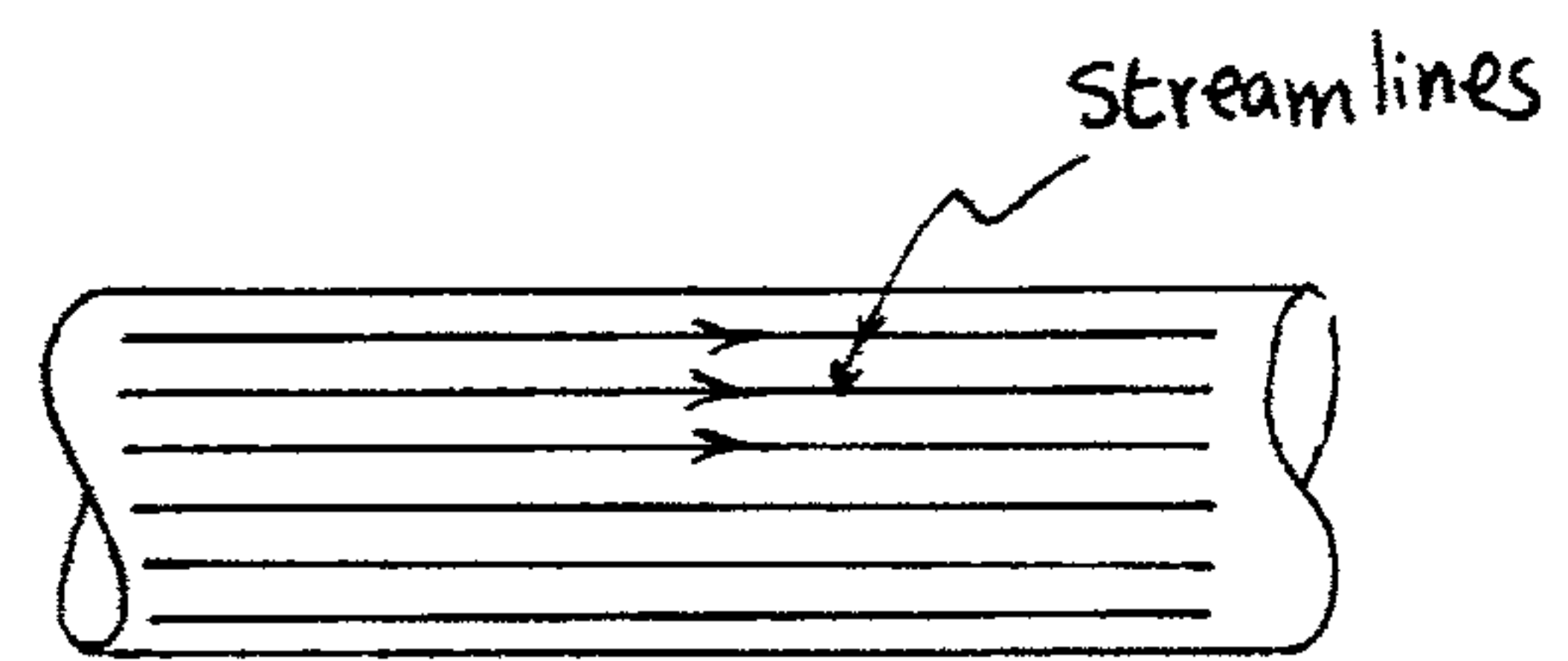

#### **b- Turbulent flow**

It occurs when fluid particles move in random motion

*e.g.* Nearly in all flow in pipes

$$R_n > 4000$$

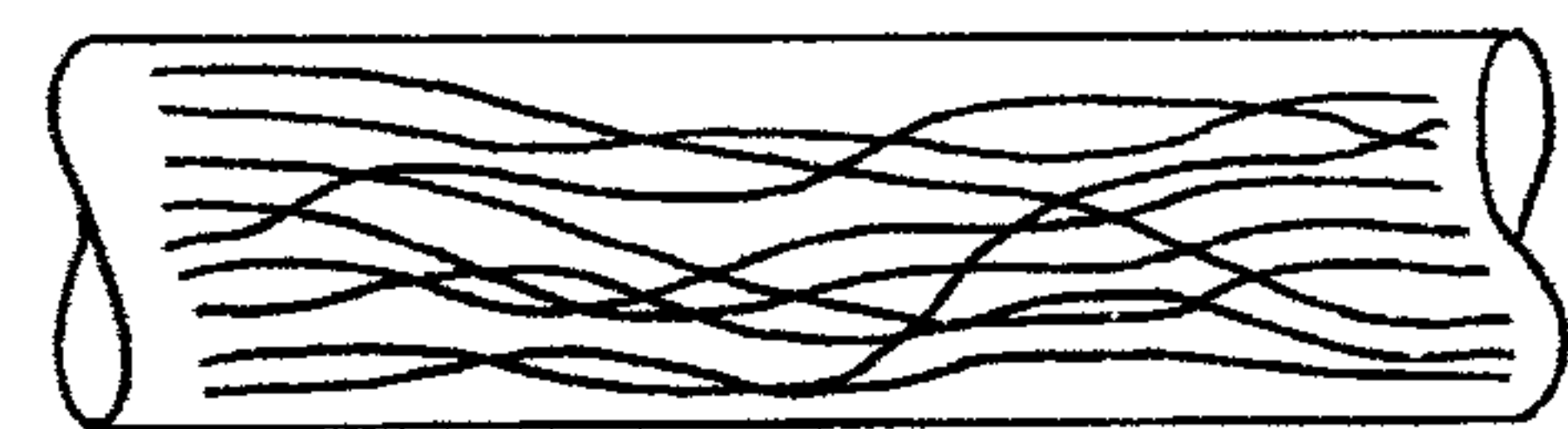

### 4- Rotational and Irrotational flow

#### **a- Rotational flow**

It occurs when fluid particles have a rotation about an axis

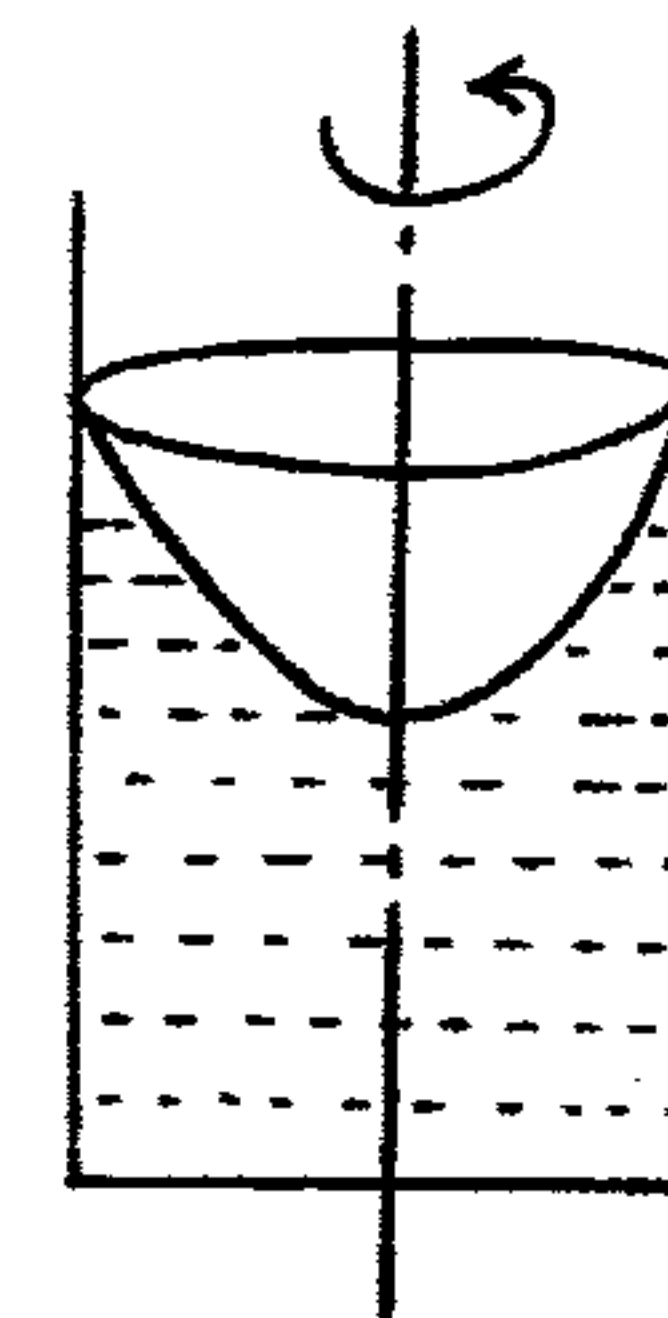

#### **b- Irrotational flow**

It occurs when fluid particles don't have a rotation about an axis

### 5- Compressible and incompressible flow

#### **a- Compressible flow**

It occurs when the density of the fluid changes from point to point

*e.g.* Flow of gases through orifices and nozzles

#### **b- Incompressible flow**

It occurs when the density is constant for fluid flow

*e.g.* Liquid are generally considered flowing incompressibly

## 6- One, two three dimensional flow

3

### **a- One dimensional flow**

It occurs when the velocity is a function of time and one co-ordinate.

$$v = f(x, t)$$

*e.g.* Flow through a straight uniform diameter pipe

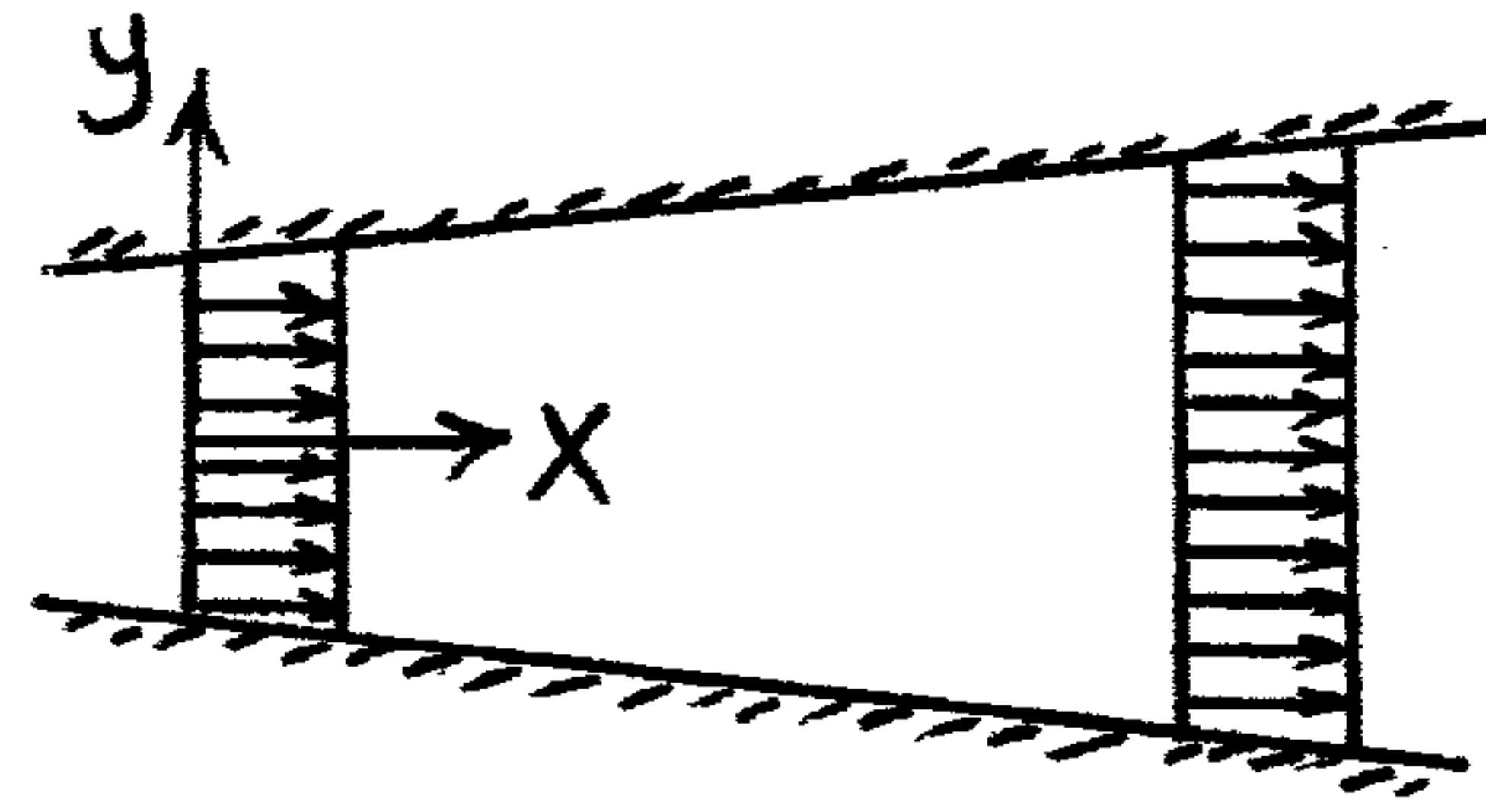

The flow is never truly 1 dimensional, because viscosity causes the fluid velocity to be zero at the boundaries.

### **b- Two dimensional flow**

It occurs when the velocity is a function of time and two co-ordinates

$$v = f(x, y, t)$$

*e.g.* Flow in the main stream of a wide river

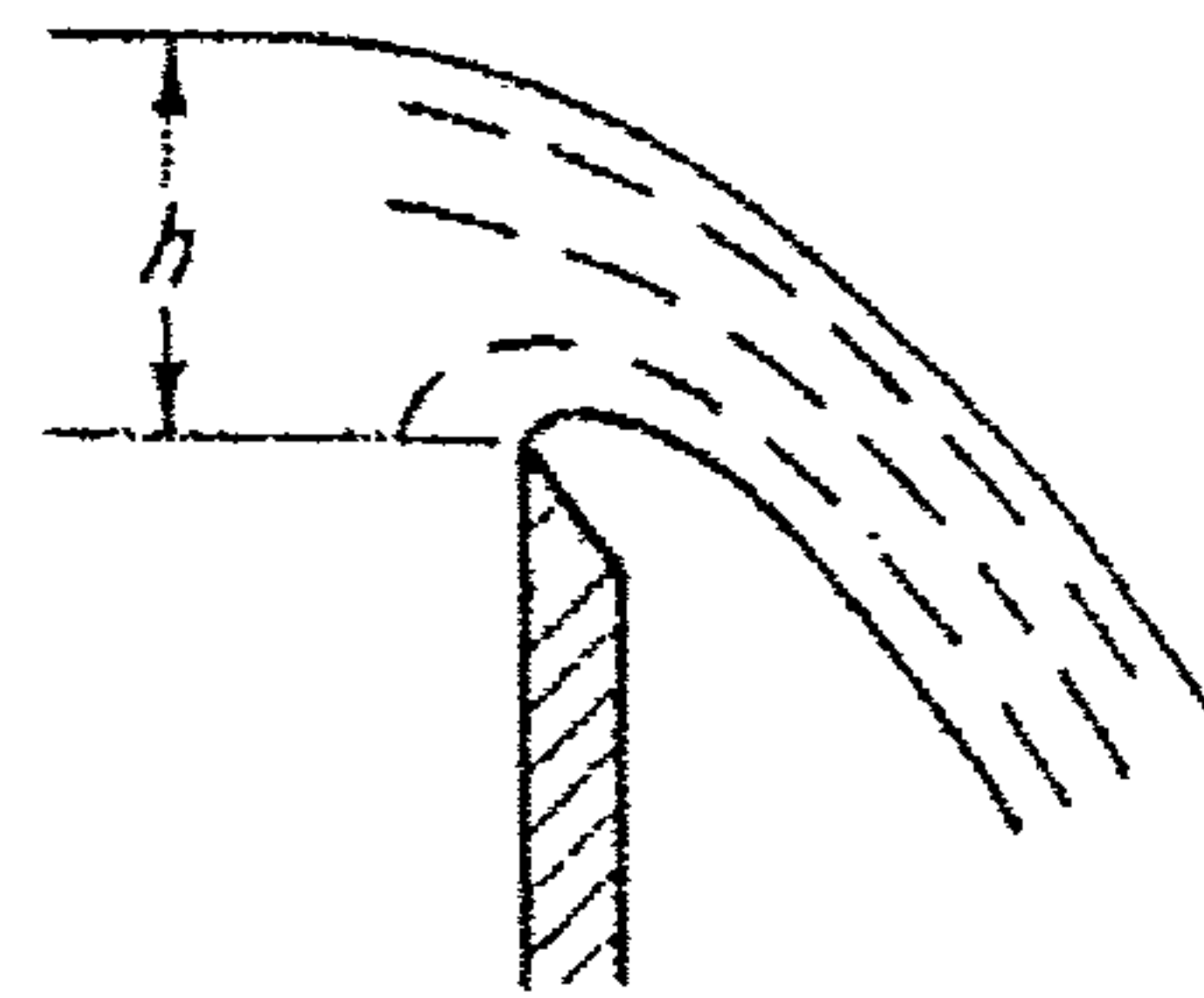
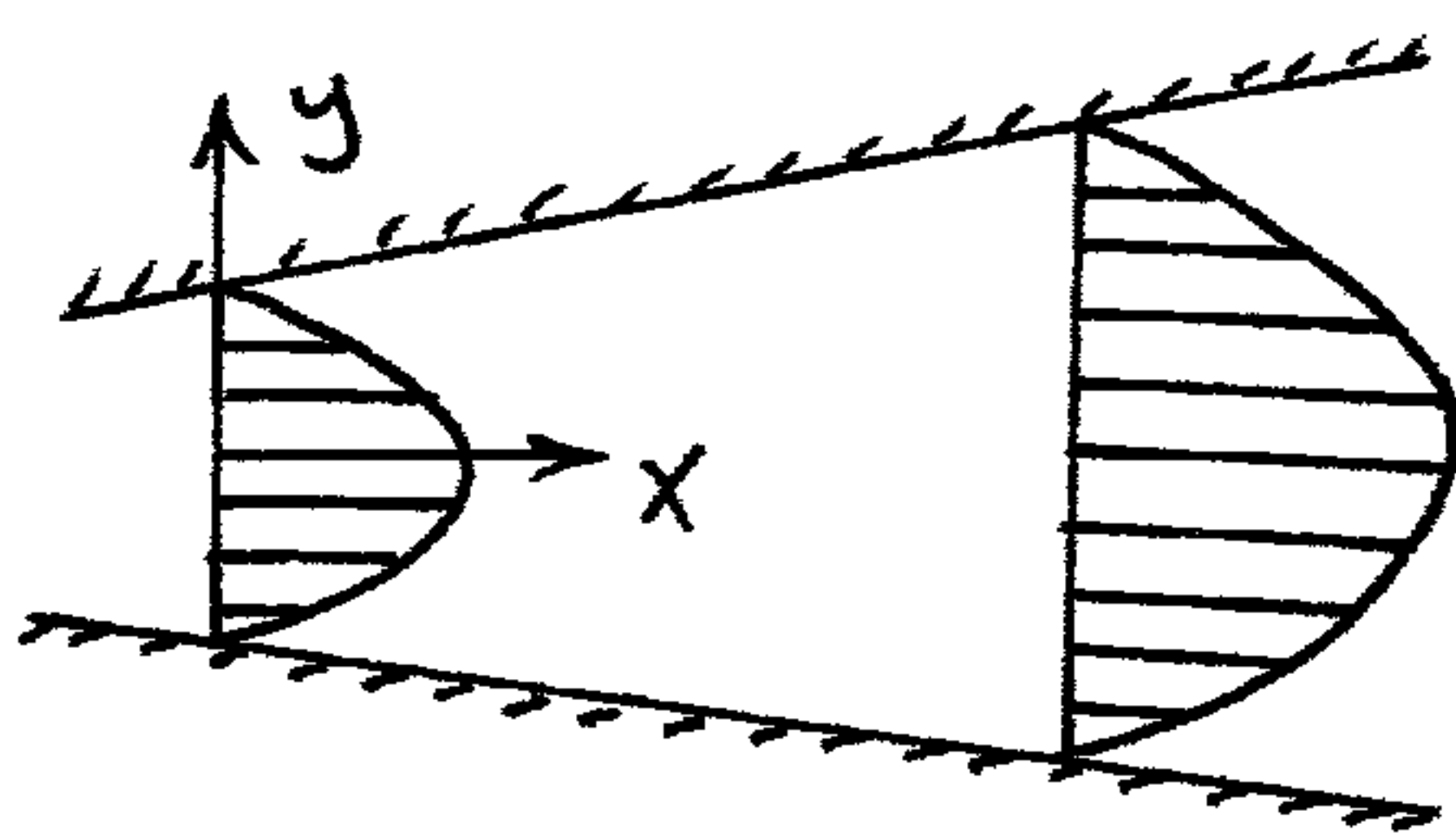

### **c- Three dimensional flow**

It occurs when the velocity is a function of time and three co-ordinates

$$v = f(x, y, z, t)$$

*e.g.* Flow in a converging or diverging pipe

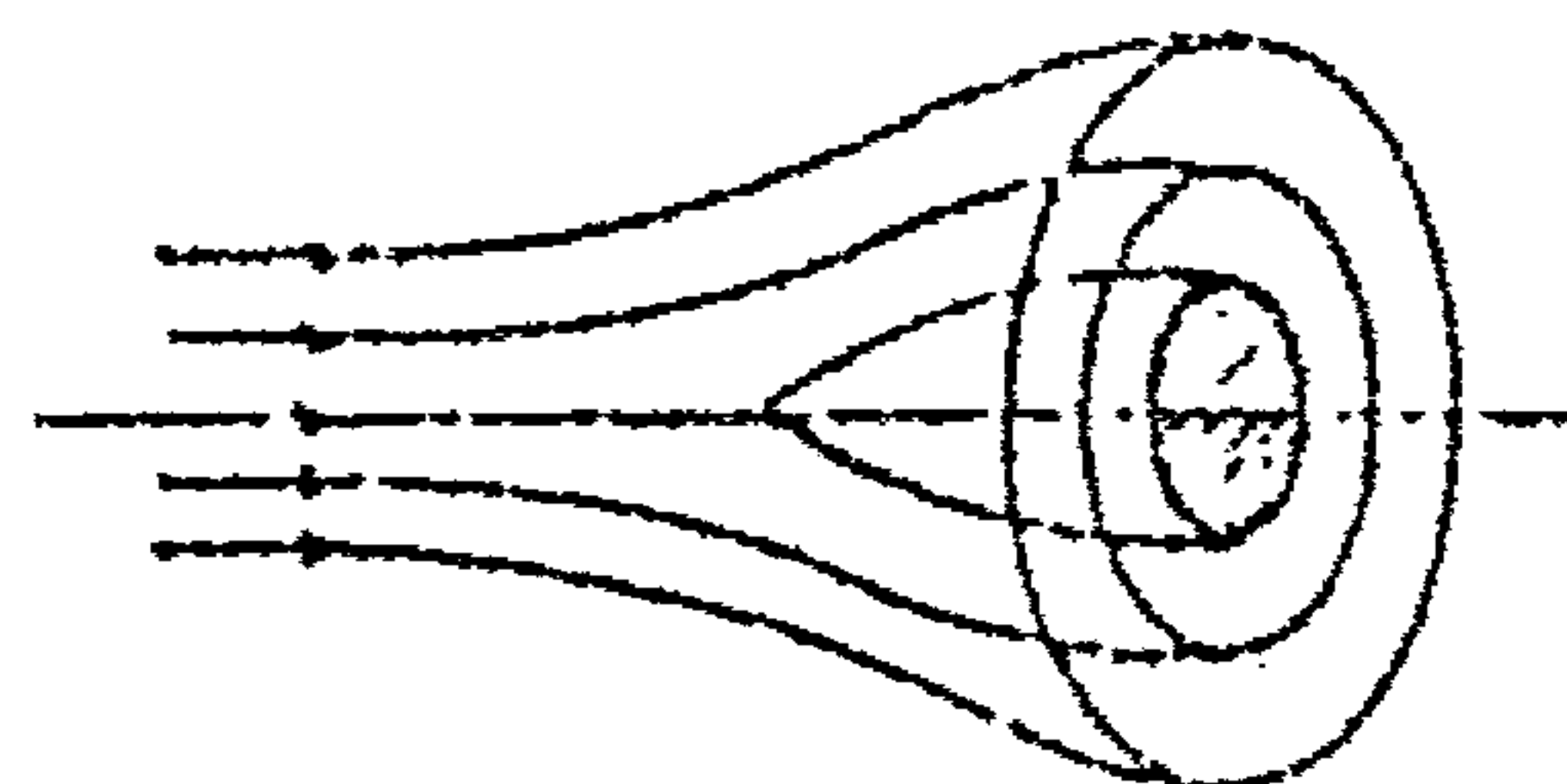
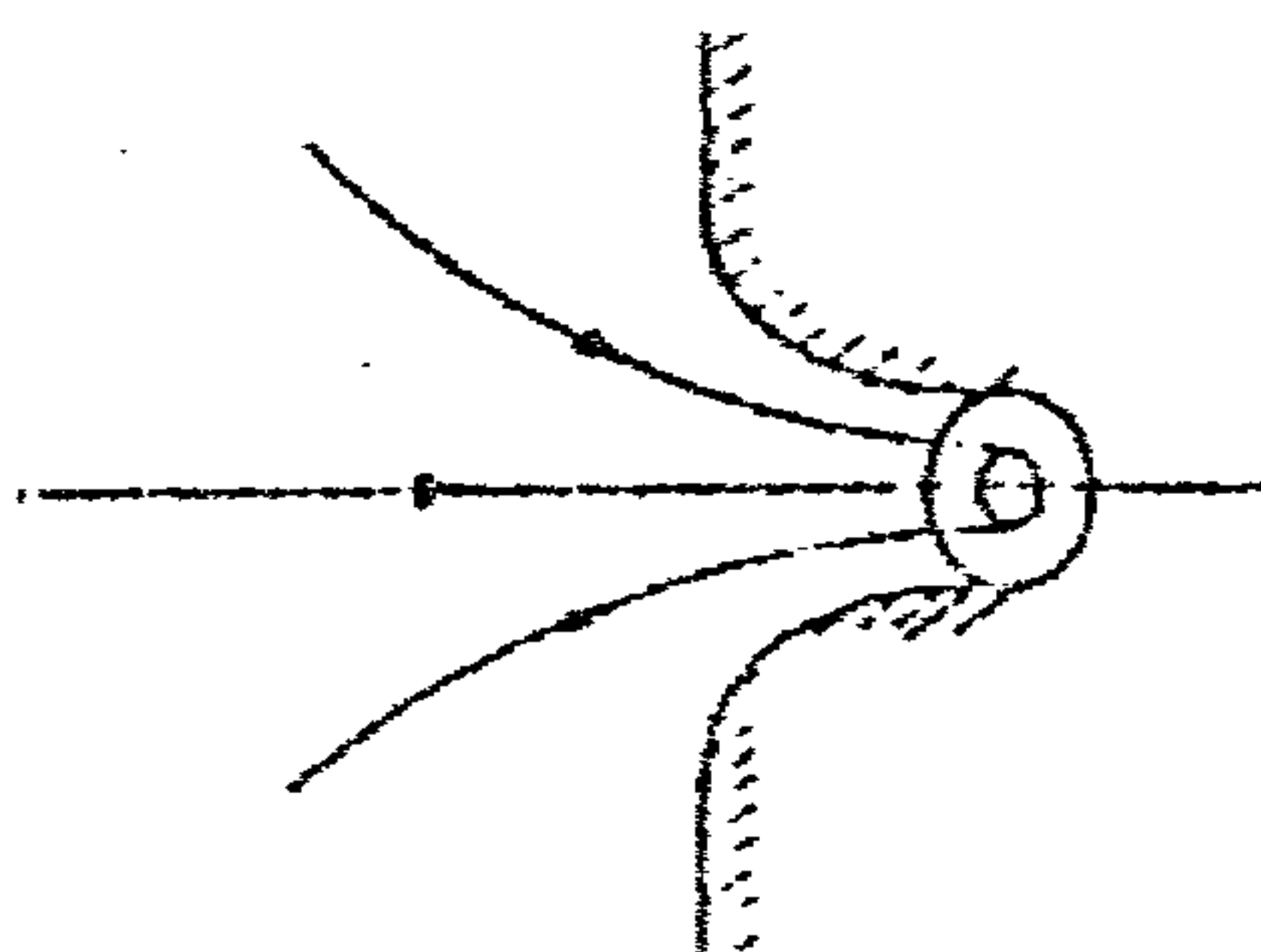

## 7- Stream lines and streamtubes

### a- Streamlines

- Streamlines are imaginary curves drawn to show the direction of fluid flow
- The tangent at any point gives the velocity direction

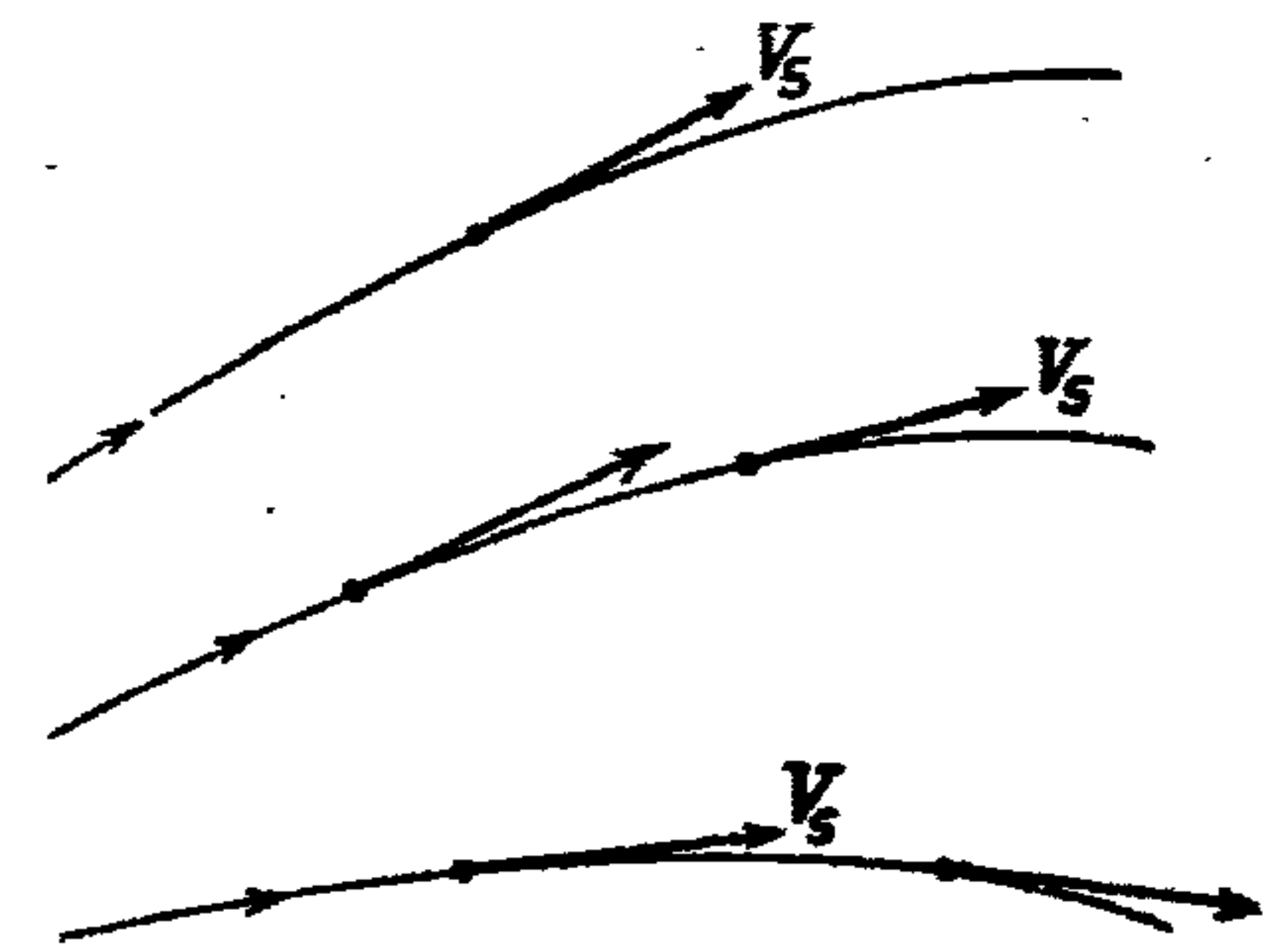

### b- Streamtubes

- A stream tube is a fluid mass bounded by a group of streamlines

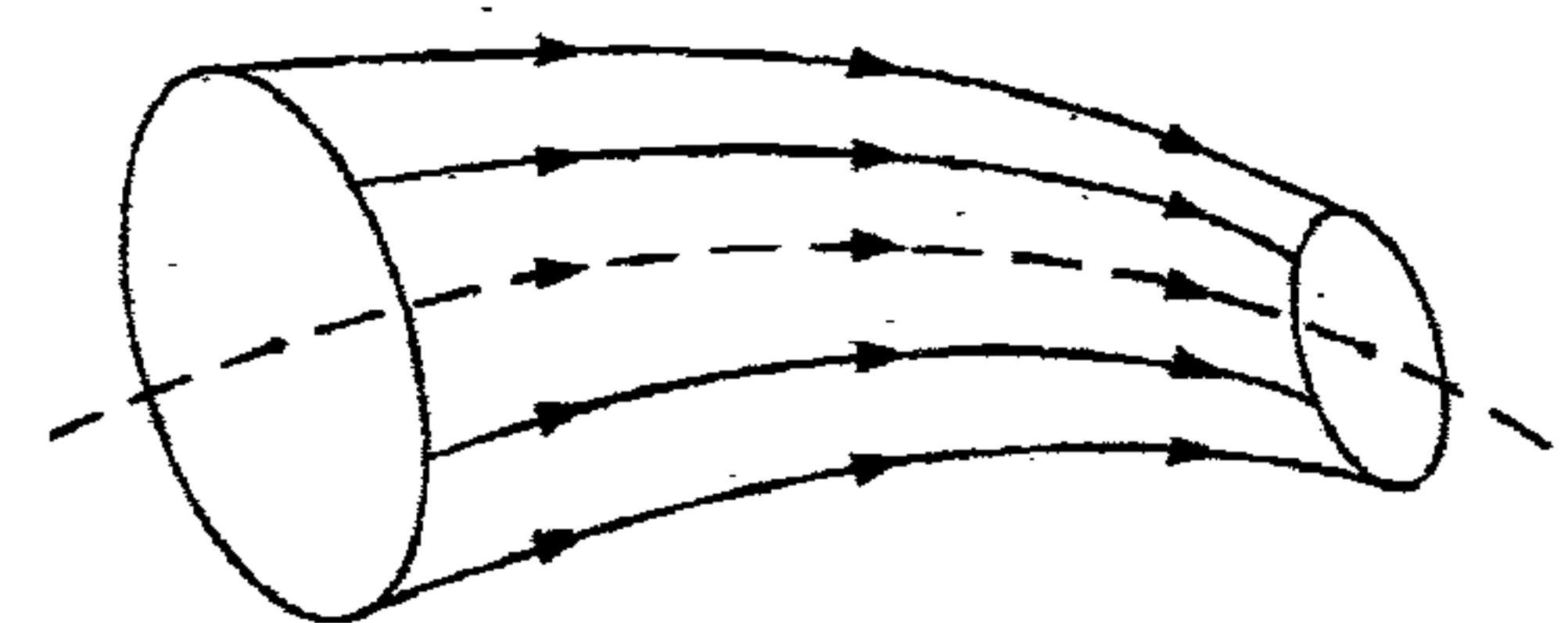

## 8- Ideal and Real Fluids

### a- Ideal Fluids

- It is a fluid that has no viscosity, and incompressible
- Shear resistance is considered zero
- Ideal fluid does not exist in nature

*e.g.* Water and air are assumed ideal

### b- Real Fluids

- It is a fluid that has viscosity, and compressible
- It offers resistance to its flow

*e.g.* All fluids in nature

## 9- Viscous and inviscid flow

### a- Viscous flow

- It occurs for fluids that have viscosity which offers shear resistance to the flow
- A part of the total energy is lost in flow

### b- Inviscid flow

- It occurs for fluids that have no viscosity
- No shear resistance to the flow
- The total energy remains constant.

## 10- Mean velocity and Discharge

### a- Mean velocity

It is the average velocity passing a given section

$$V_{\text{mean}} = \frac{Q}{A}$$

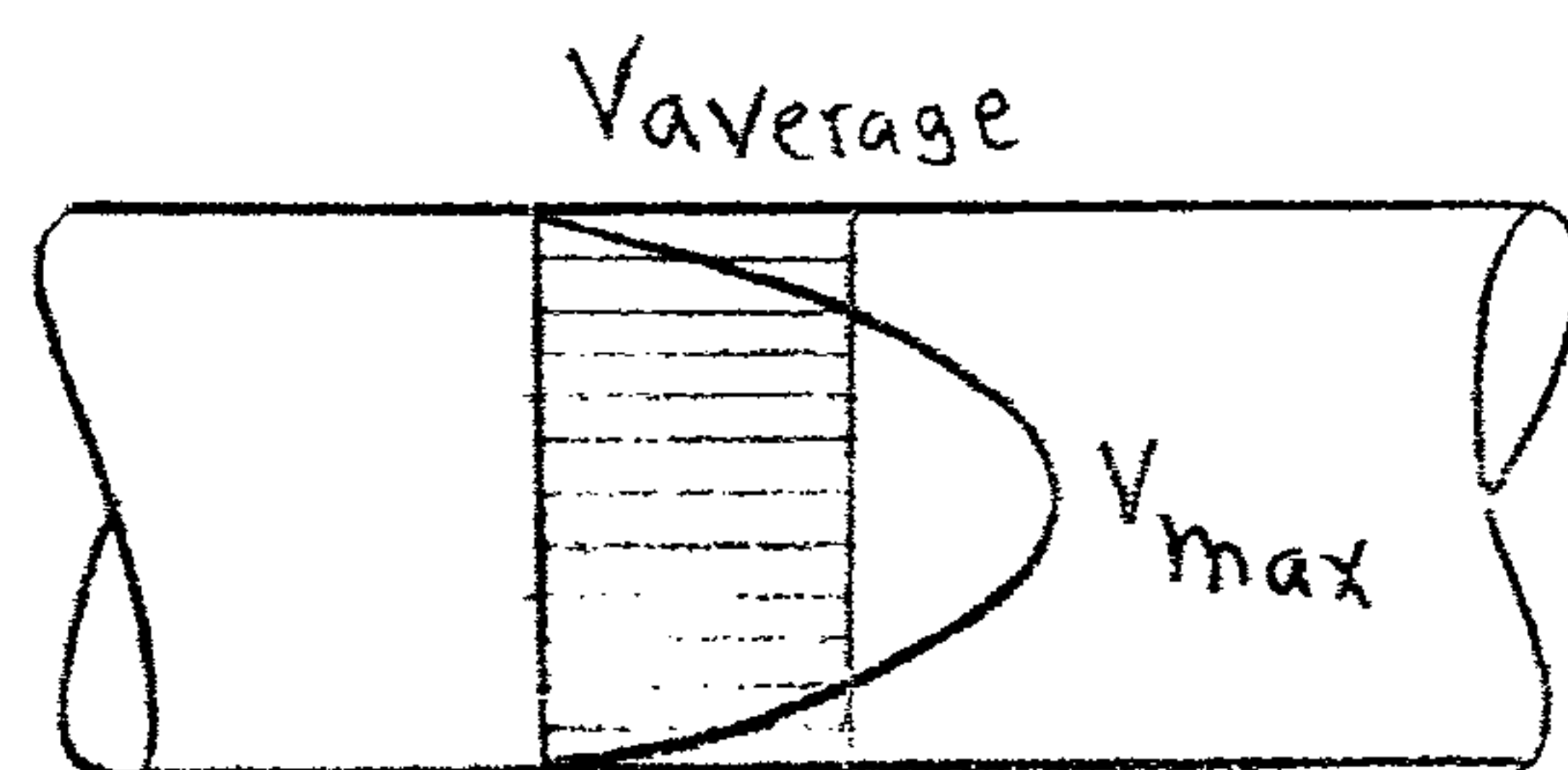

### b- Discharge

It is the rate of Volume of liquid passing a given cross-section

$$Q = \frac{V}{t} = A \cdot v$$

# The Continuity equation

⑥

If no fluid is added or removed from the pipe in any length then the Mass passing across different sections shall be the same

$$dM_1 = dM_2$$

$$\rho_1 dA_1 \frac{dS_1}{dt} = \rho_2 dA_2 \frac{dS_2}{dt}$$

$$\rho_1 dA_1 V_1 = \rho_2 dA_2 V_2$$

$$\rho_1 A_1 V_1 = \rho_2 A_2 V_2$$

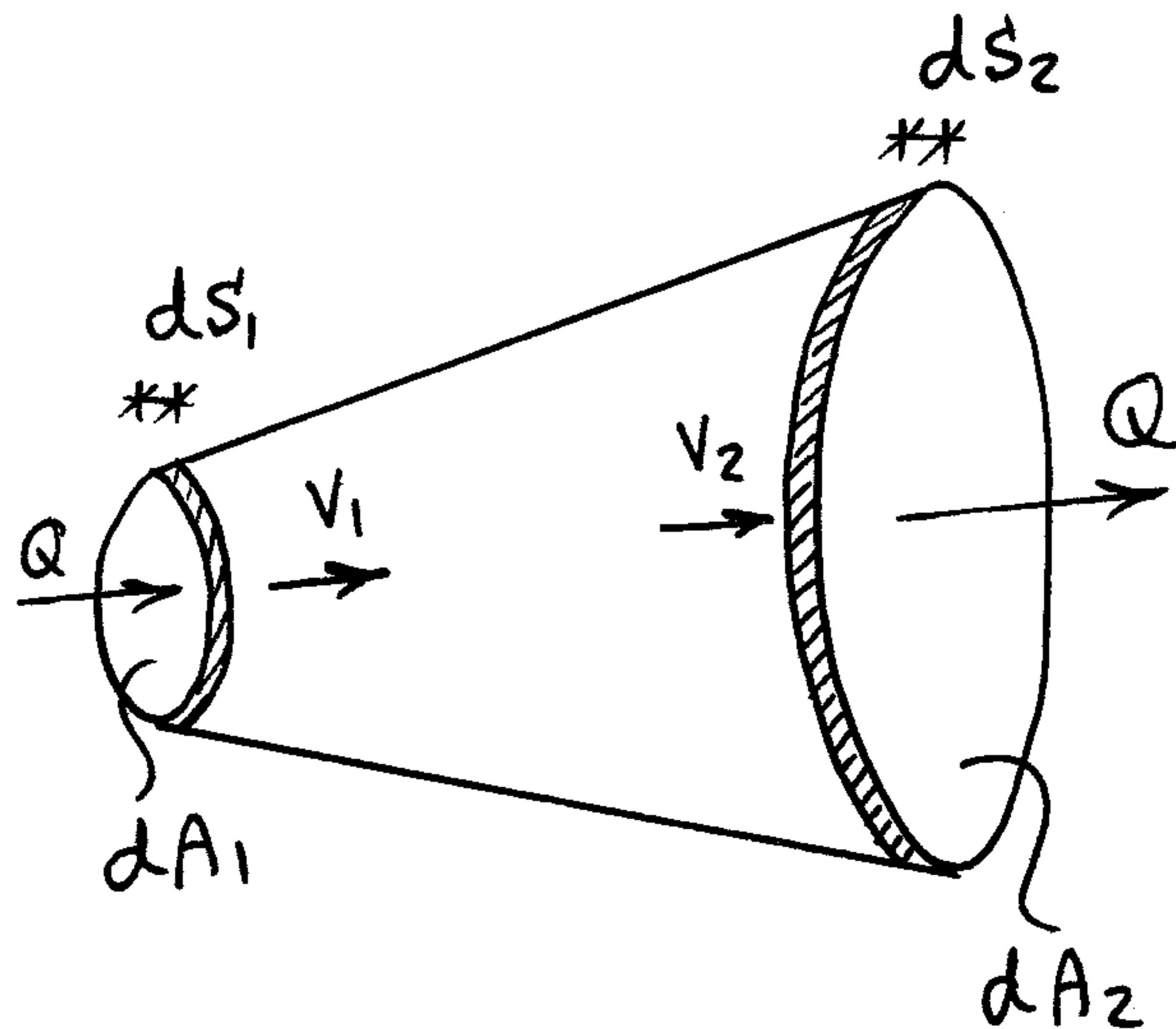

For incompressible fluids  $\rho_1 = \rho_2$

$$A_1 V_1 = A_2 V_2$$

$$\left[ \begin{array}{l} \text{m}^3/\text{sec} \\ \text{cm}^3/\text{sec} \\ \text{ft}^3/\text{sec} \end{array} \right] \quad \text{L}^3/\text{T}$$

$$Q = \text{Discharge} = \text{Area} * \text{Velocity} = A \cdot V$$

$$= \text{Flow rate} = \frac{\text{Volume}}{\text{Time}} = \frac{V}{t}$$

$$Q = \text{Constant}$$

$$\text{Input} = \text{Output}$$

e.g

$$Q_1 = Q_2 + Q_3$$

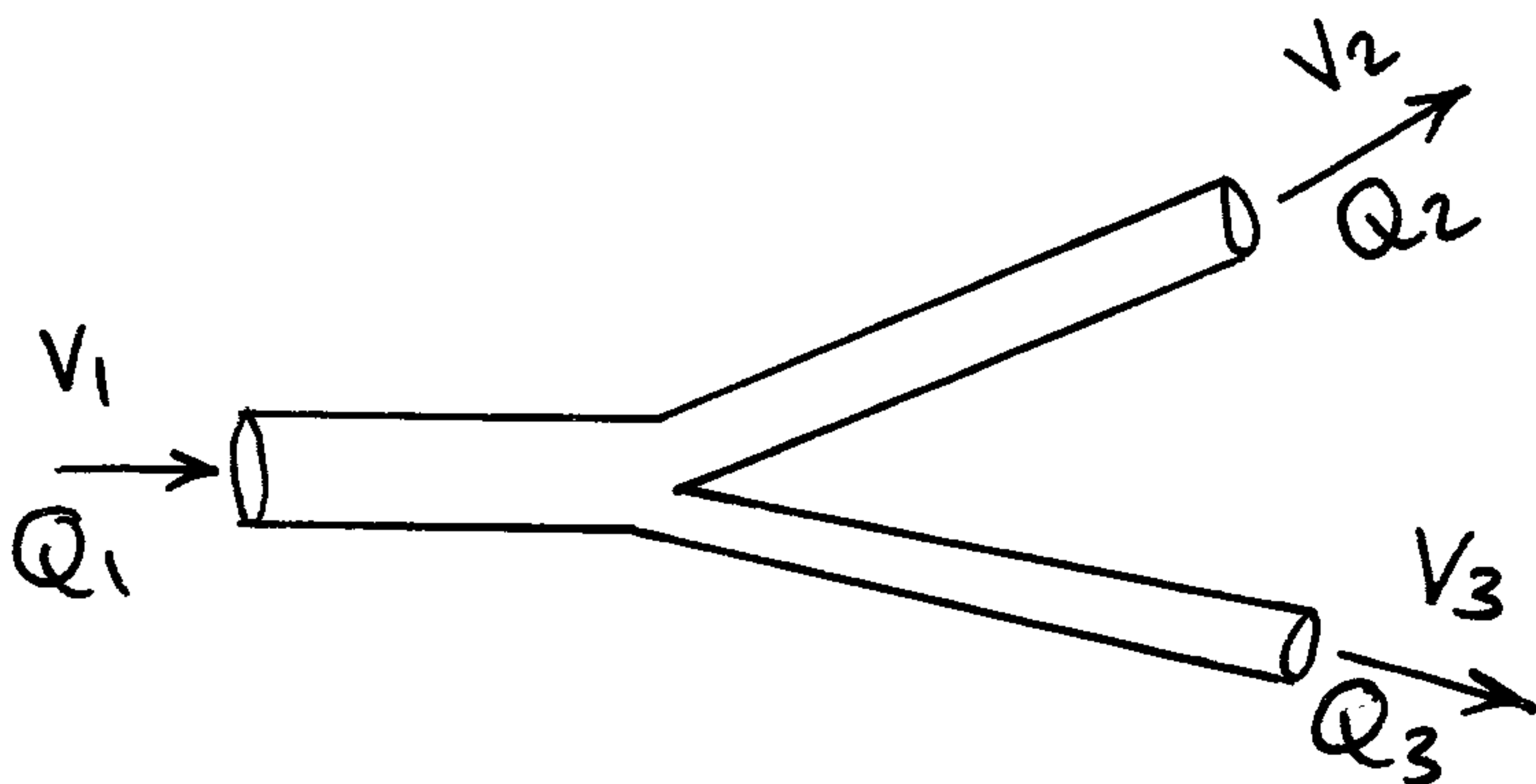

(3)

$$Q_C = ? \quad Q_D = ?$$

$$V_B = ? \quad V_C = ?$$

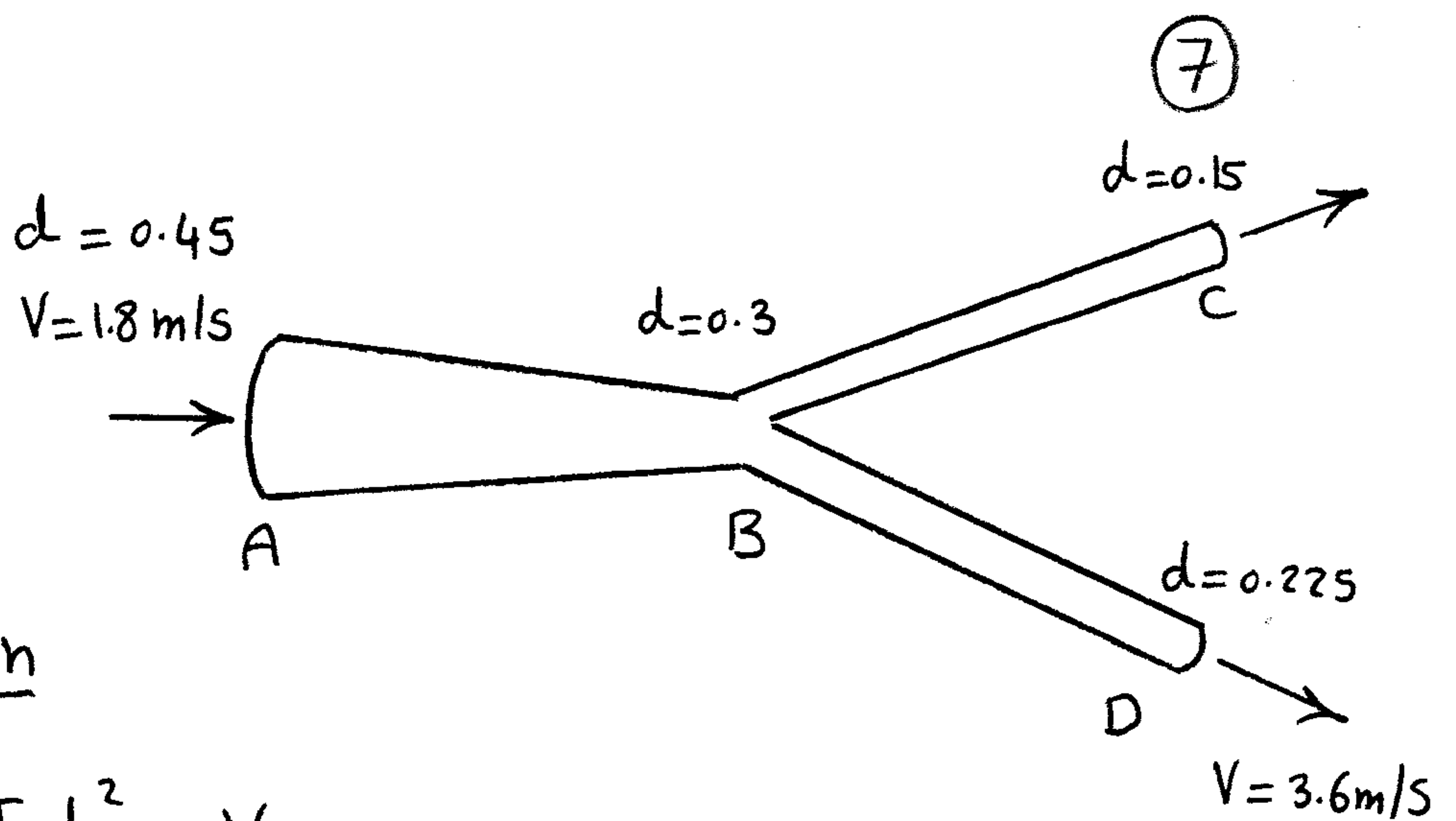

Applying Continuity eqn

$$Q_A = A \cdot V = \frac{\pi d^2}{4} * V$$
$$= \frac{\pi (0.45)^2}{4} * 1.8 = 0.286 \text{ m}^3/\text{s}$$

$$Q_D = AV = \frac{\pi (0.225)^2}{4} * 3.6 = \underline{\underline{0.143 \text{ m}^3/\text{s}}}$$

$$Q_A = Q_C + Q_D$$

$$0.286 = Q_C + 0.143 \quad \Rightarrow \quad Q_C = \underline{\underline{0.143 \text{ m}^3/\text{s}}}$$

$$V_C = \frac{Q_C}{A_C} = \frac{0.143}{\frac{\pi (0.15)^2}{4}} = \underline{\underline{8.09 \text{ m/s}}}$$

$$Q_B = Q_A = 0.286 \text{ m}^3/\text{s}$$

$$V_B = \frac{Q_B}{A_B} = \frac{0.286}{\frac{\pi (0.3)^2}{4}} = \underline{\underline{4.04 \text{ m/s}}}$$



# Fluid Dynamics

⑧

For any Fluid element it has

Three energies or heads

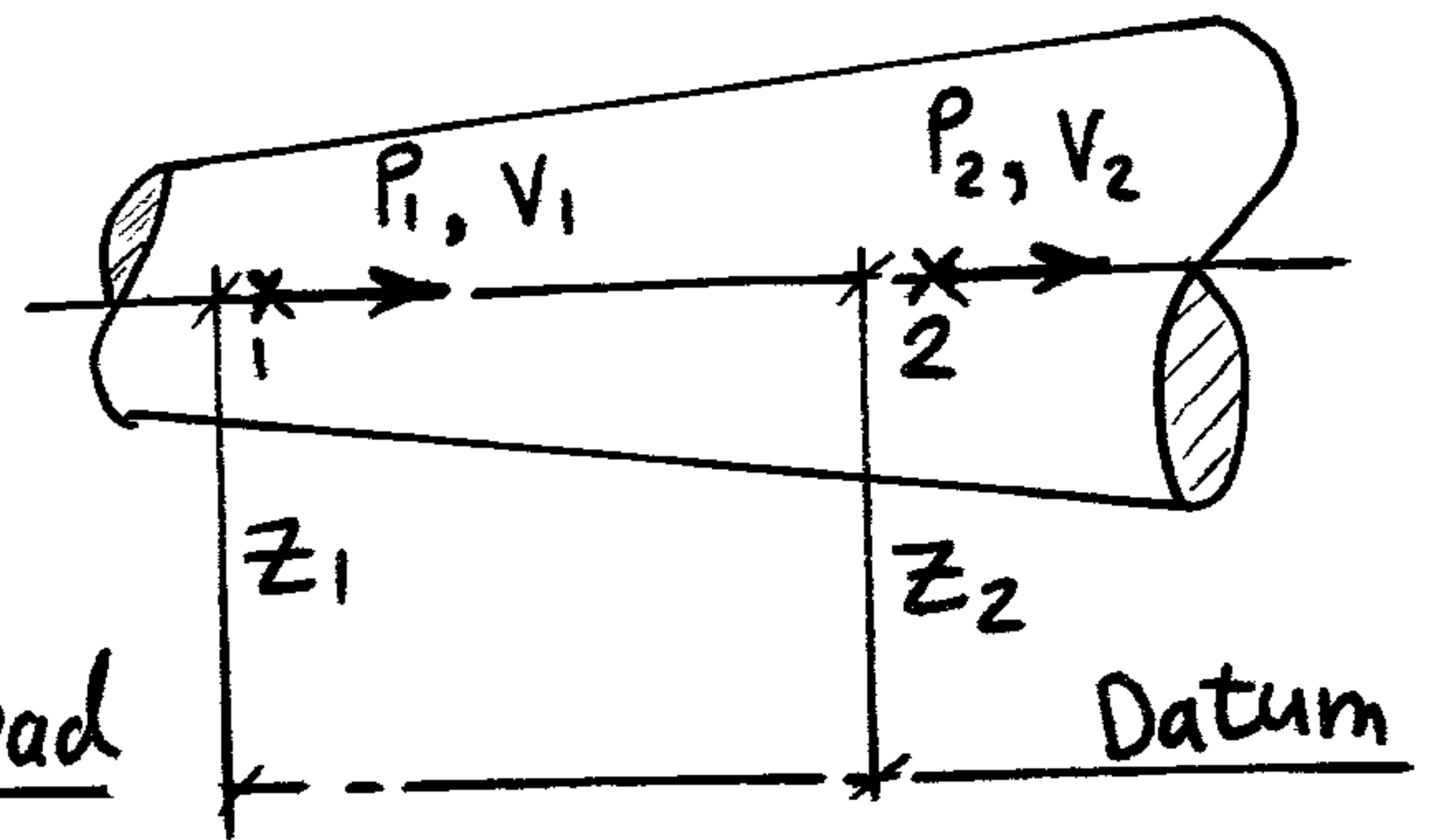

1- Potential energy or Potential head

$$P.E = MgZ$$

$$\text{Potential head} = \frac{P.E}{\text{unit Weight}} = \frac{MgZ}{Mg} = Z$$

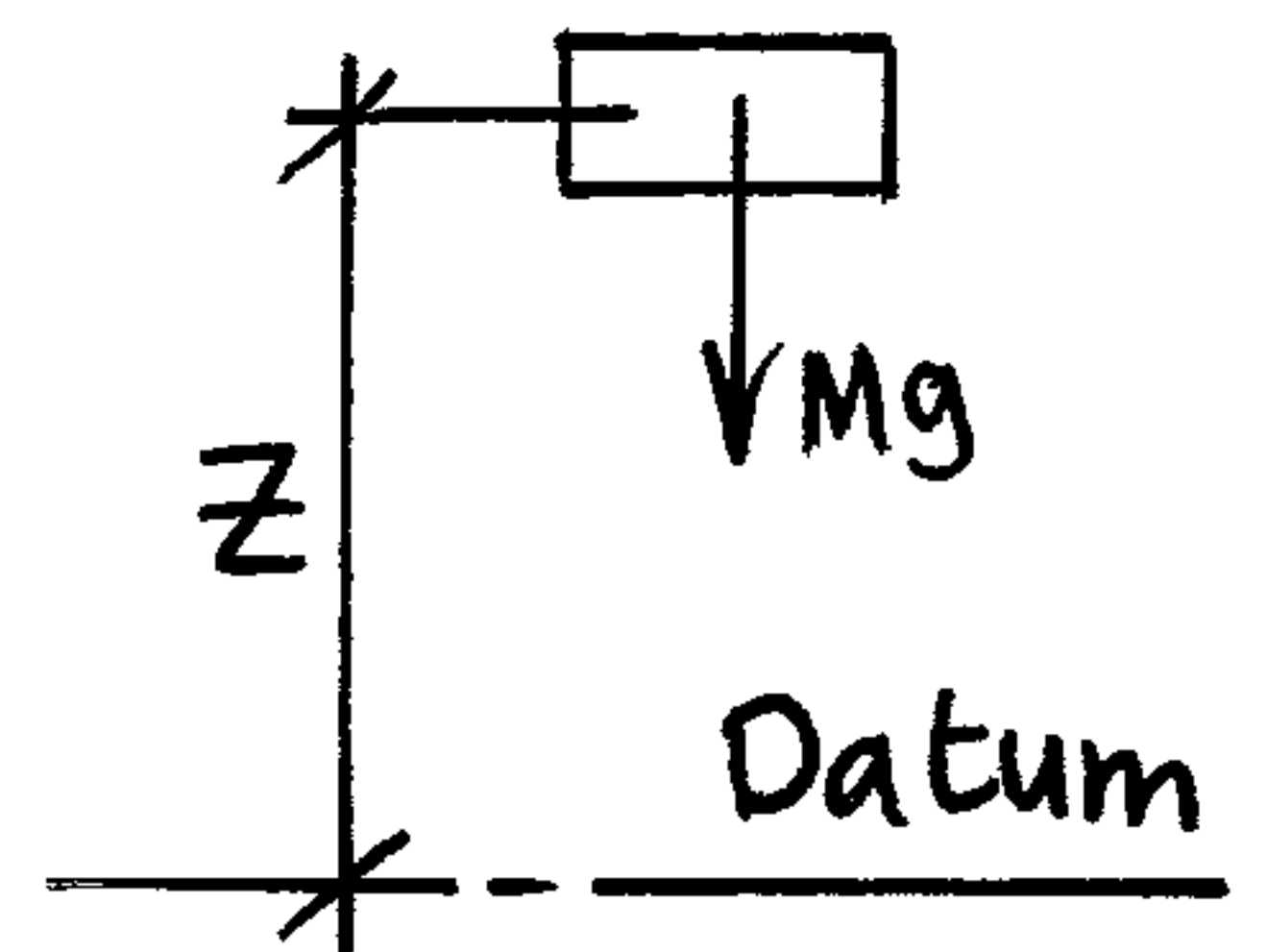

2- Kinetic energy or Velocity head

$$K.E. = \frac{MV^2}{2}$$

$$\text{Velocity head} = \frac{K.E.}{\text{unit Weight}} = \frac{MV^2}{2Mg} = \frac{V^2}{2g}$$

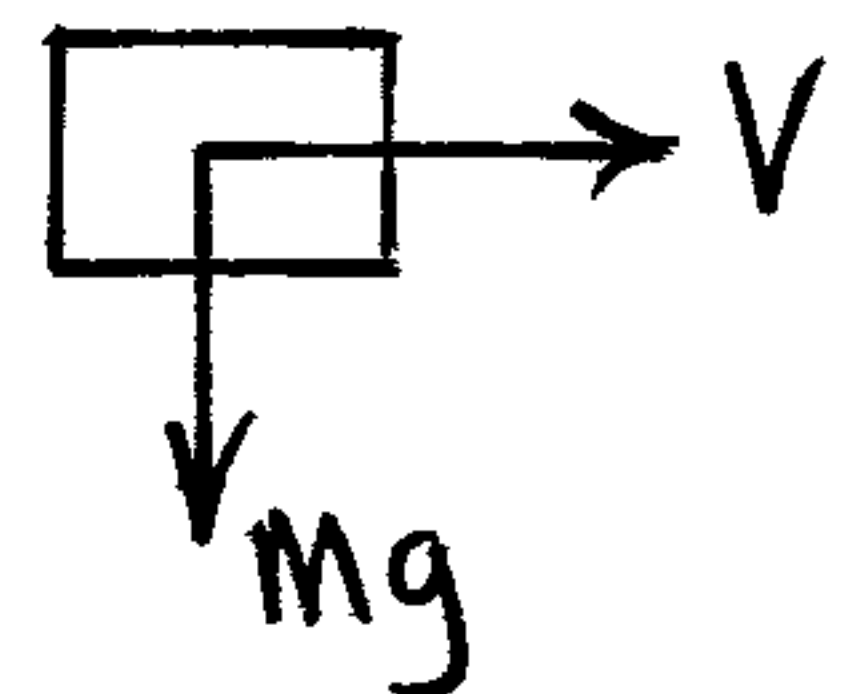

$$\frac{V^2}{2g} = \frac{L^2 T^{-2}}{L T^{-1}} = (L)$$

3- Pressure energy or Pressure head

$$\text{Pressure energy} = (\gamma h). A. X$$

$$\text{Pressure head} = \frac{\text{Pressure energy}}{\text{unit weight}}$$

$$= \frac{\gamma h A X}{\gamma A X} = h = (L)$$

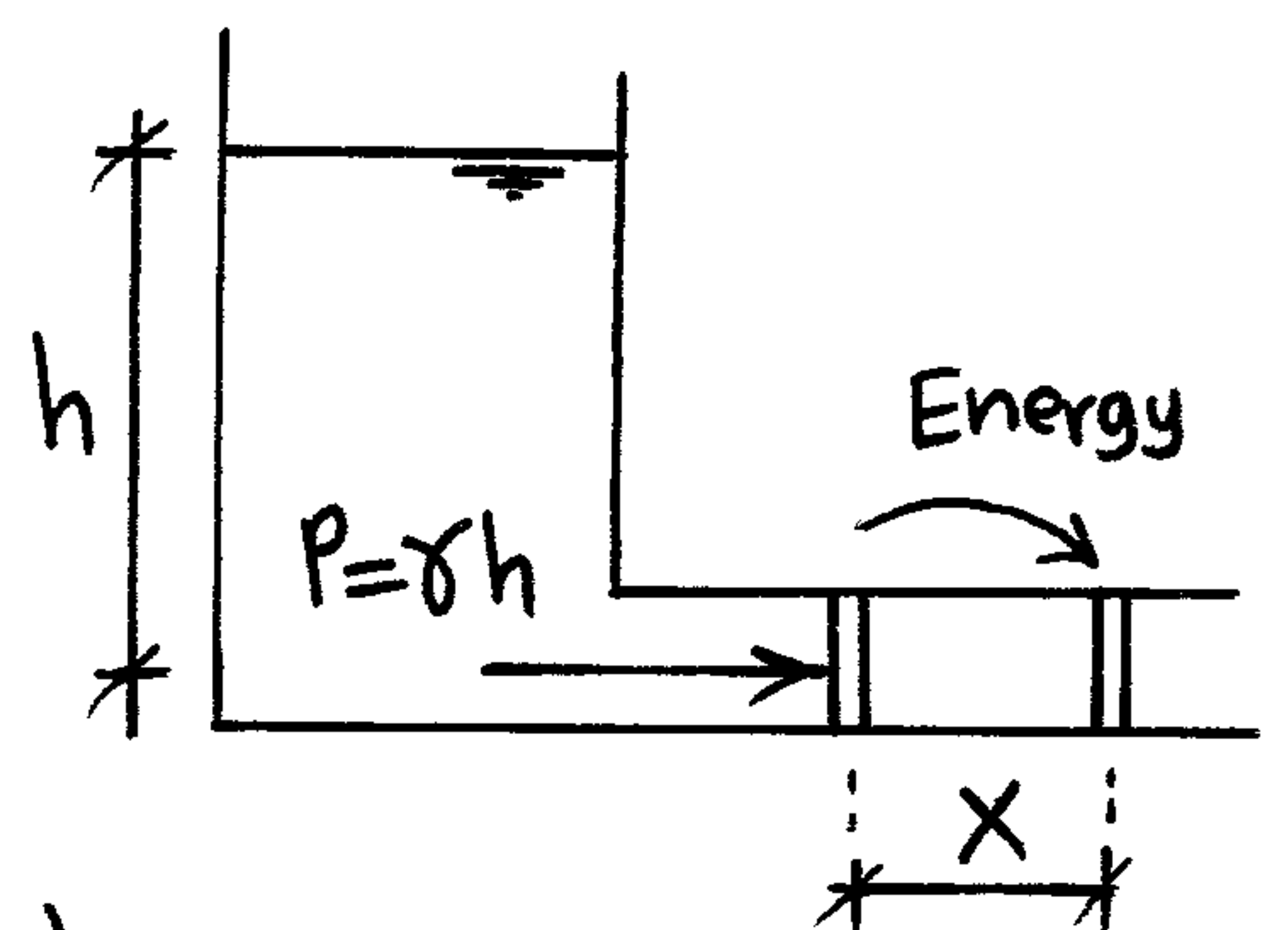

# Ideal Fluid

## Euler & Bernoulli's eqn

Consider a fluid element of cross-section  $dA$  and length  $dS$  moving along a streamline.

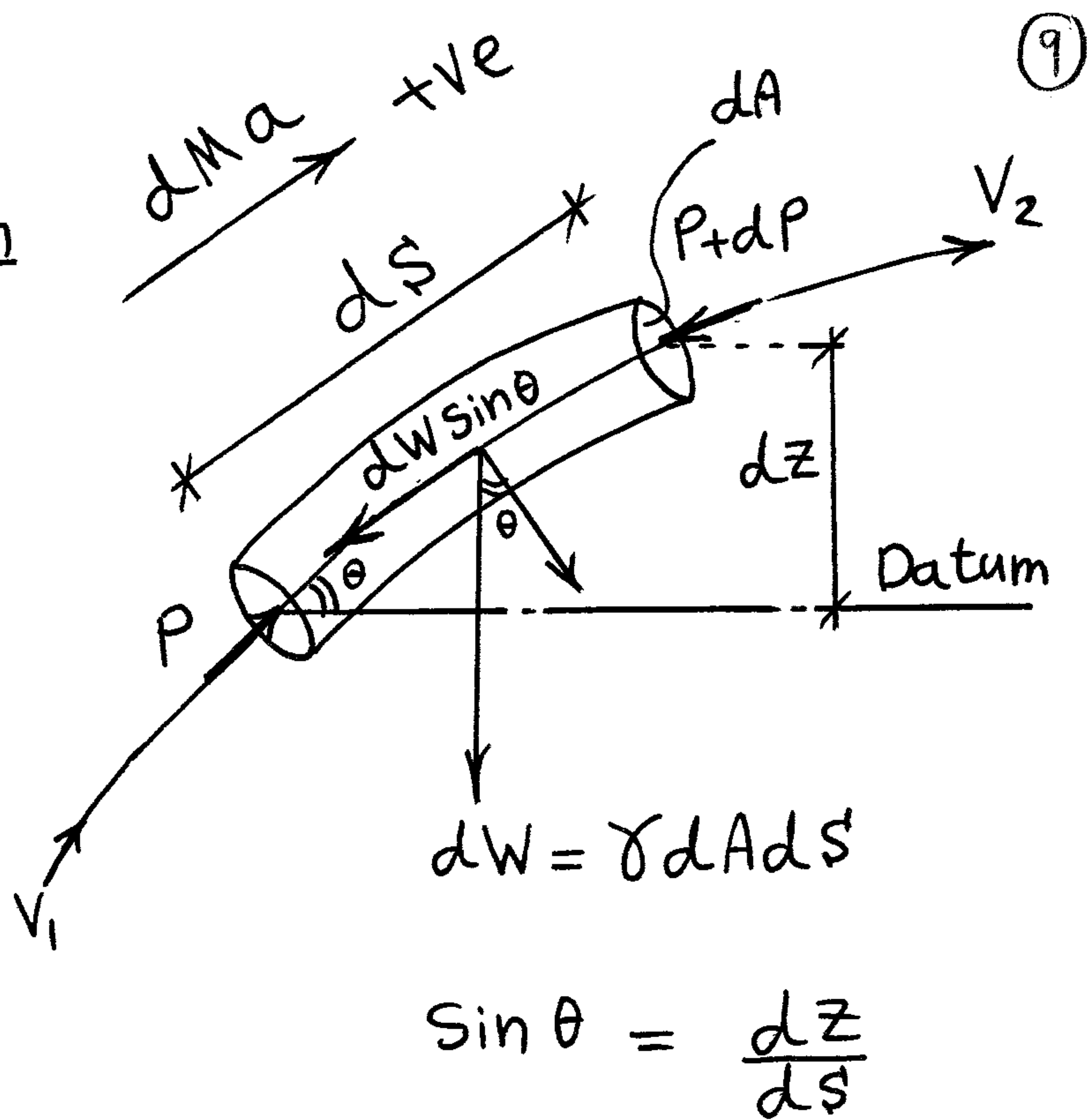

## Applying Newton 2<sup>nd</sup> law

$$P dA - (P + dP) dA - dW \sin \theta = dMa$$

$$\cancel{P dA} - \cancel{P dA} - dP dA - \gamma dA dS \left( \frac{dz}{dS} \right) = \rho dA dS \frac{dV}{dt}$$

$$-dP - \gamma dz = \rho dS \frac{dV}{dt} \quad \div \gamma$$

$$-\frac{dP}{\gamma} - dz - \frac{\rho}{\gamma} \left( \frac{dS}{dt} \right) dV$$

Euler's eqn

$$\frac{dP}{\gamma} + dz + \frac{V dV}{g} = 0$$

## Equation of Steady motion along a Streamline

By integration of Euler's equation

Bernoulli's eqn

$$\frac{P}{\gamma} + Z + \frac{V^2}{2g} = \text{Constant}$$

Pressure head + Position head + Velocity head = Total head 57

# Real Fluid

Real fluid has an additional force acting caused by Friction

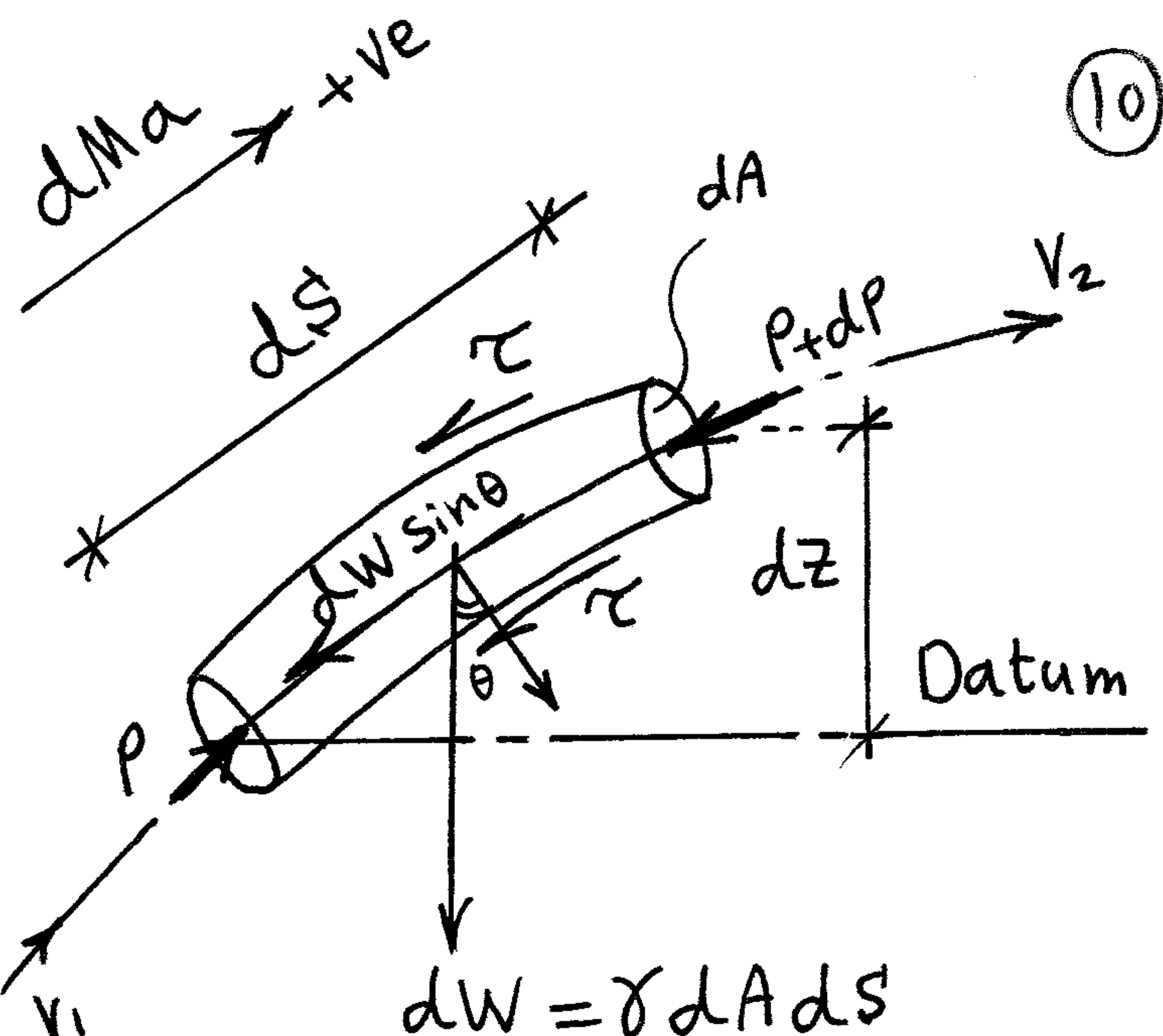

$$F = \tau dA = \tau (2\pi r) ds$$

Applying Newton 2<sup>nd</sup> law

$$dW = \gamma dA ds$$

$$\sin \theta = \frac{dz}{ds}$$

$$P dA - (P + dP) dA - dW \sin \theta - \tau (2\pi r) ds = dMa$$

$$-dP dA - \gamma dA ds \left( \frac{dz}{ds} \right) - \tau \left( \frac{2dA}{r} \right) ds = \rho dA ds \frac{dV}{dt}$$

$$\therefore dA = \pi r^2 \quad \div \gamma$$

$$-\frac{dP}{\gamma} - dz - \frac{2\tau ds}{\gamma r} = \frac{V dV}{g}$$

$$\frac{dP}{\gamma} + dz + d\left(\frac{V^2}{2g}\right) = -\frac{2\tau ds}{\gamma r}$$

$$\int_1^2 \frac{dP}{\gamma} + \int_1^2 dz + \int_1^2 d\left(\frac{V^2}{2g}\right) = \int_1^2 \frac{-2\tau ds}{\gamma r}$$

$$\left( \frac{P_1}{\gamma} + z_1 + \frac{V_1^2}{2g} \right) - \frac{2\tau L}{\gamma r} = \left( \frac{P_2}{\gamma} + z_2 + \frac{V_2^2}{2g} \right)$$

$$\text{Dims of } \frac{2\tau L}{\gamma r} = \frac{N/m^2 * m}{N/m^3 * m} = m$$

$$H_1 \text{ (Total energy at Sec 1)} - h_L \text{ (head lost)} = H_2 \text{ (T.E. at Sec 2)}$$

① → ②

Total Energy Line

T.E.L.

T.E.L.

(11)

هو خط يمثل مجموع الـ ٣ طاقات في معادلة Bernoulli  $\left(\frac{P}{\gamma} + \frac{V^2}{2g} + Z\right)$

وحيث أن مجموعهم ثابت فإنه يظل أفقياً وموازياً لل datum في حالة عدم وجود losses

نعتبر الـ flow دائماً Ideal ولا إذا ذكر وجود losses

Hydraulic Gradient Line

H.G.L.

H.G.L.

هو عبارة عن خط يمثل مجموع Static head  $\left(\frac{P}{\gamma} + Z\right)$  وبالتالي فهو

يبعد بمقدار  $\left(\frac{V^2}{2g}\right)$  Dynamic head من الـ T.E.L.

هو الخط الذي يمر بالأماكن التي عندها الضغط يساوي صفر (Imaginary free Surface)

Examples on Ideal Fluid

e.g.1

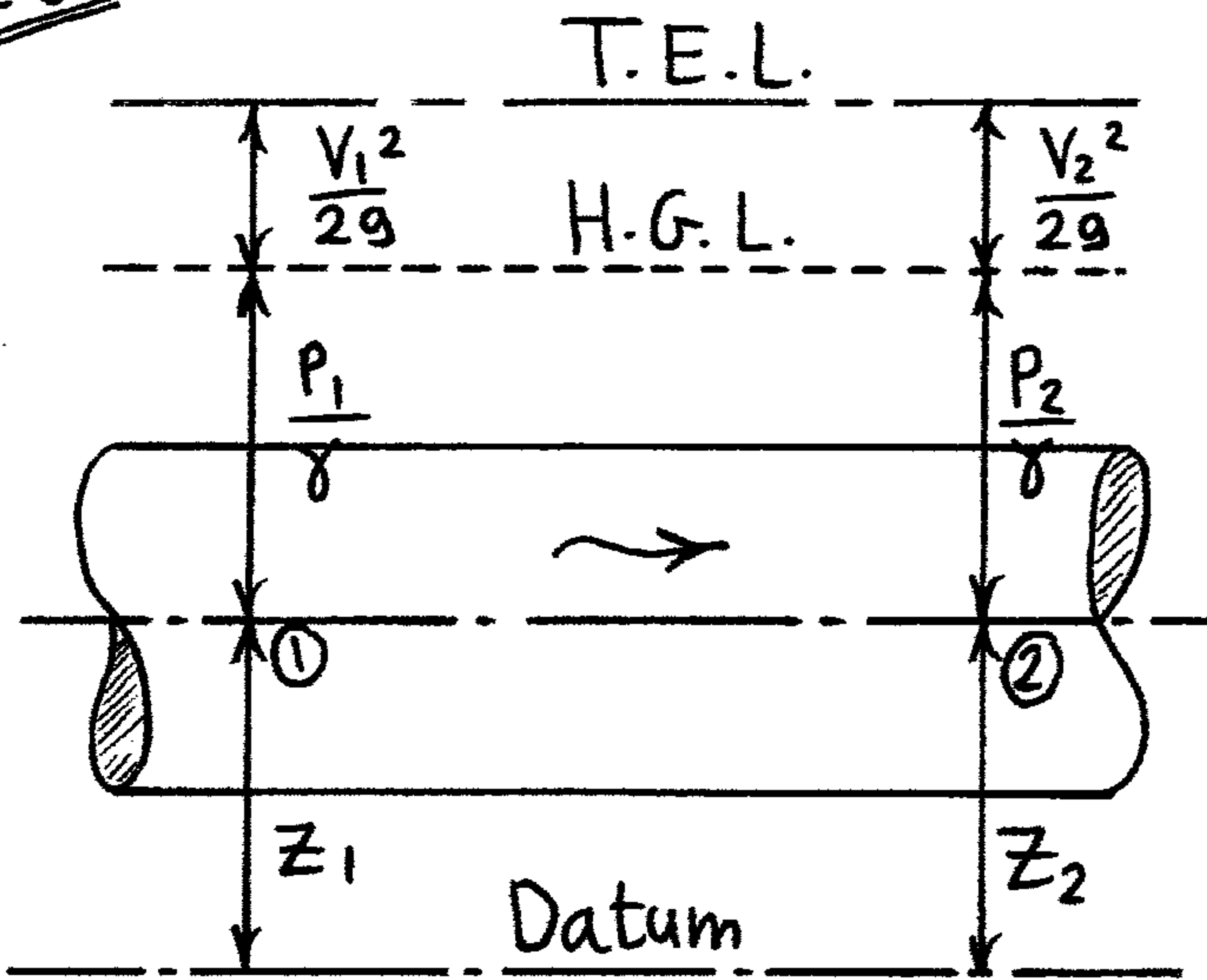

e.g.2

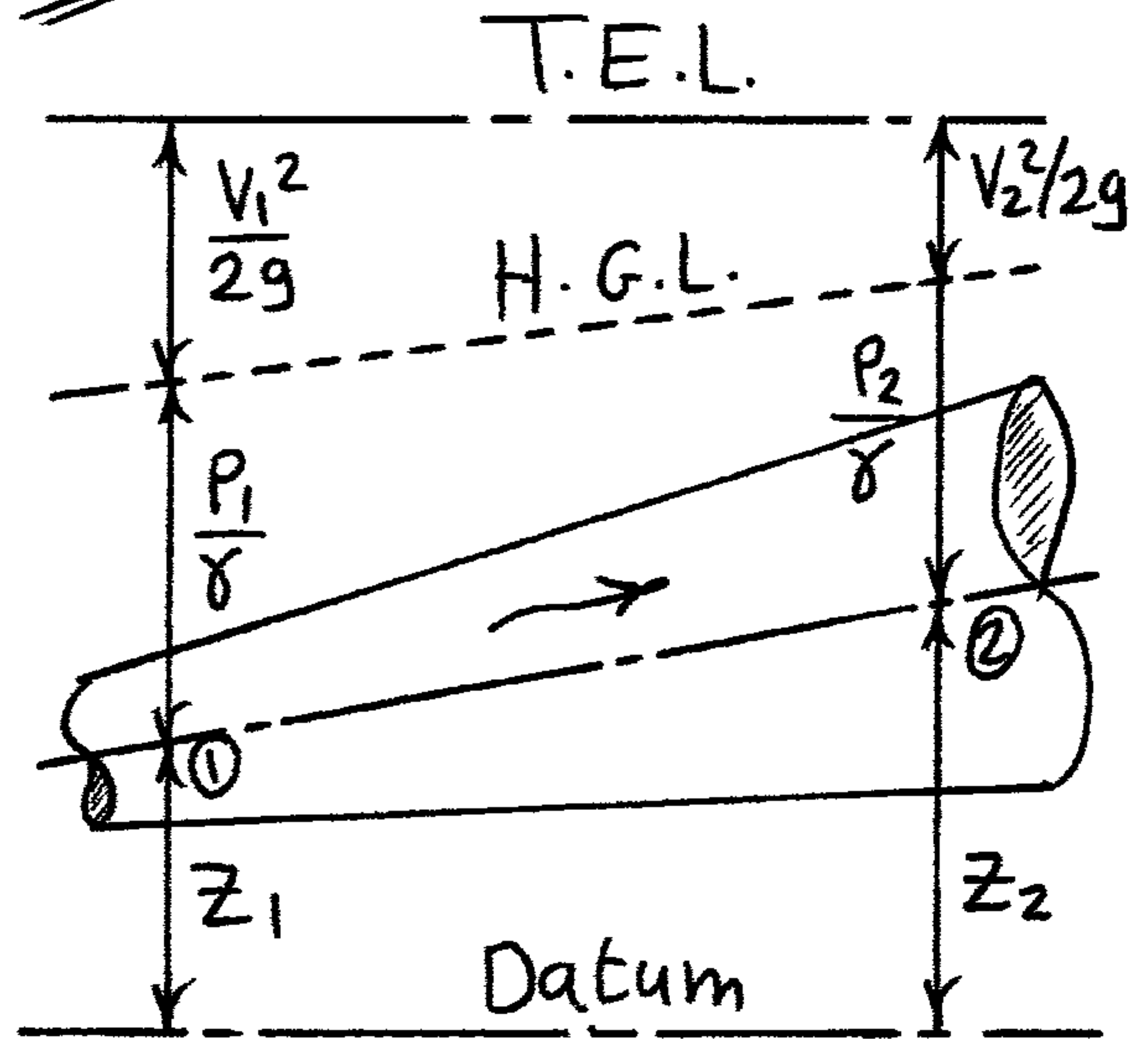

في حالة أنه مقطع الأنبوبة ثابت فإنه

السرعة تظل ثابتة وبما أنه الـ T.E.L. أفقى

فإن الـ H.G.L. يكون أفقى وموازياً للـ T.E.L.

في حالة أنه مقطع الأنبوبة يزيد فإنه

السرعة تقل وبما أنه الـ T.E.L. أفقى

فإن الـ H.G.L. يزيد تدريجياً

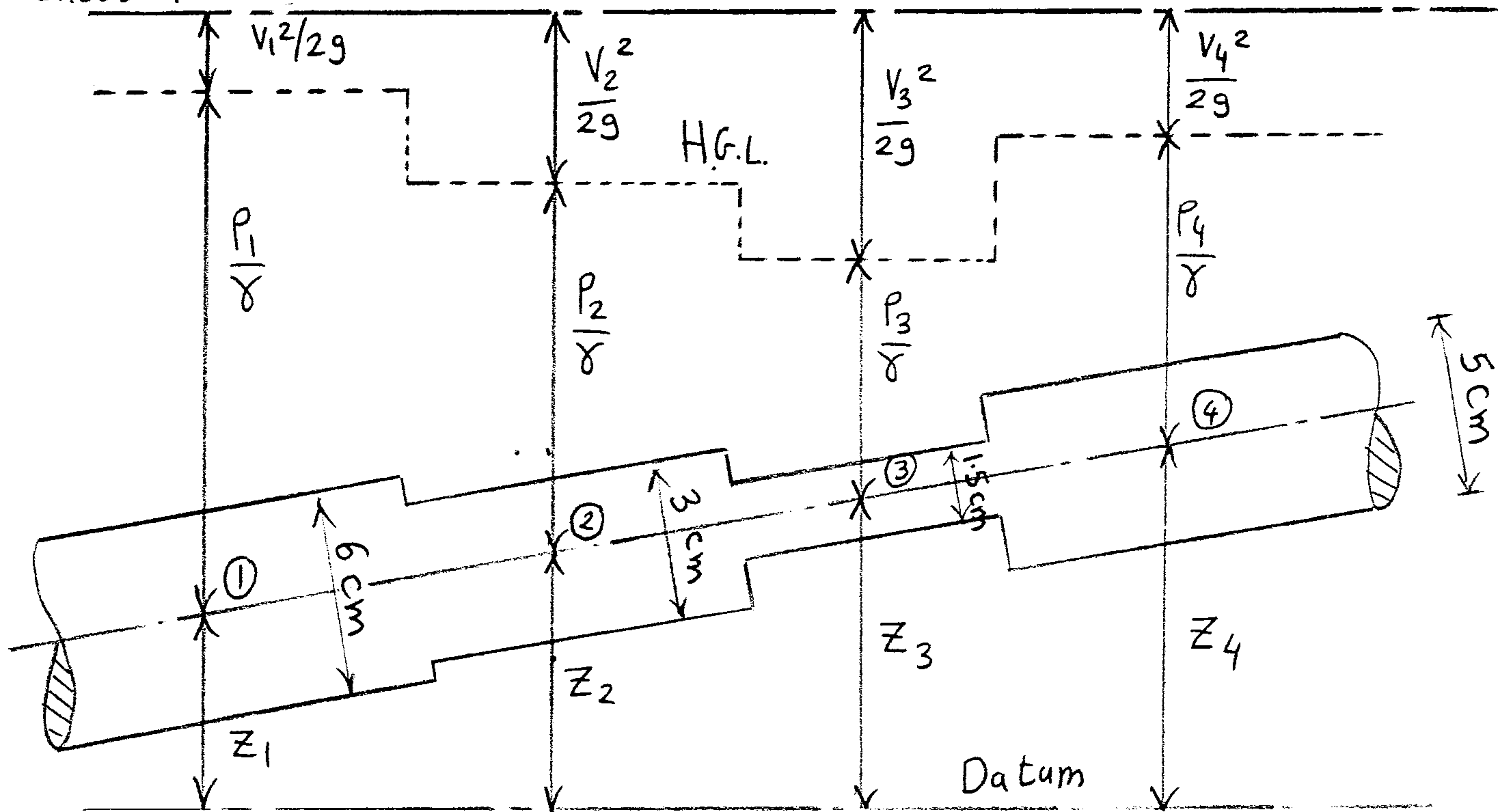

في حالة أنه مقطع الأنبوبة يضيء فجأة فإيه السرعة تزيد فجأة فيقل الـ H.G.L.  
 فجأة والعكس صحيح

Example on H.G.L

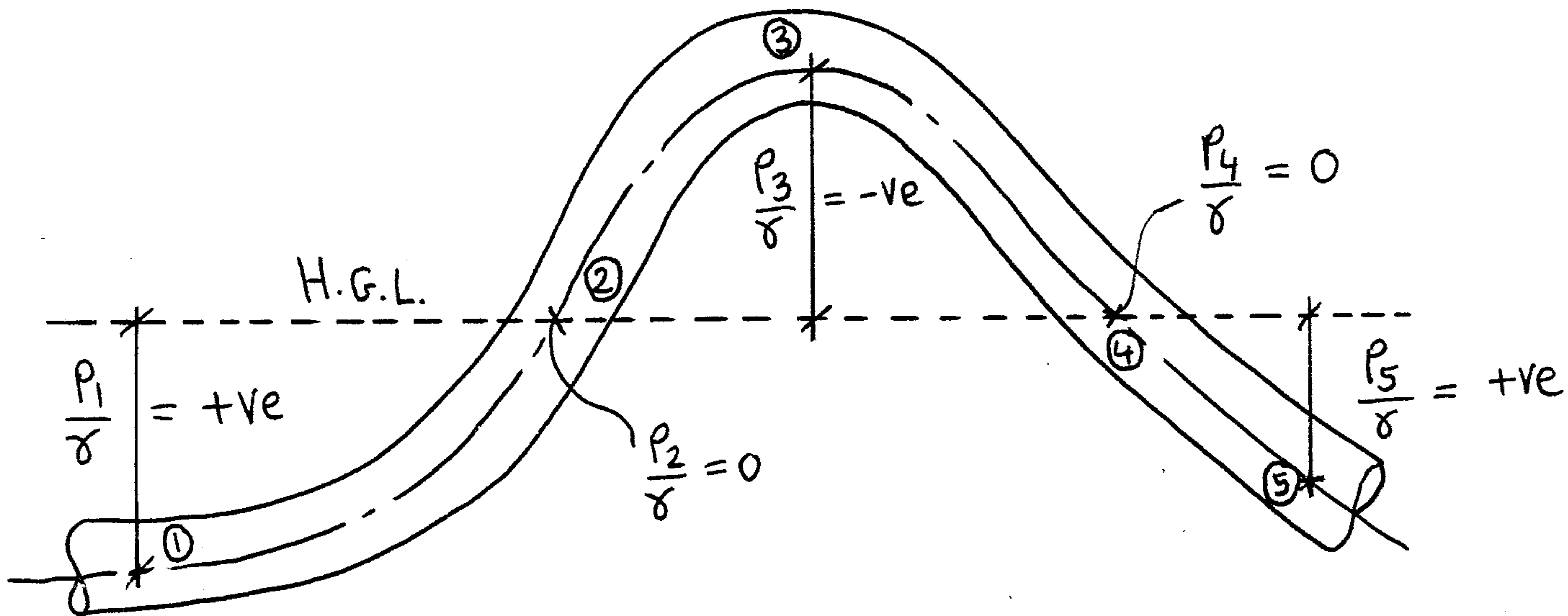

- 1) H.G.L above pipe's Centerline have +ve Pressure
- 2) H.G.L below pipe's Centerline have -ve Pressure
- 3) Centerline intersecting with H.G.L. have Zero Pressure

# Example on Real Fluid

(13)

## Losses

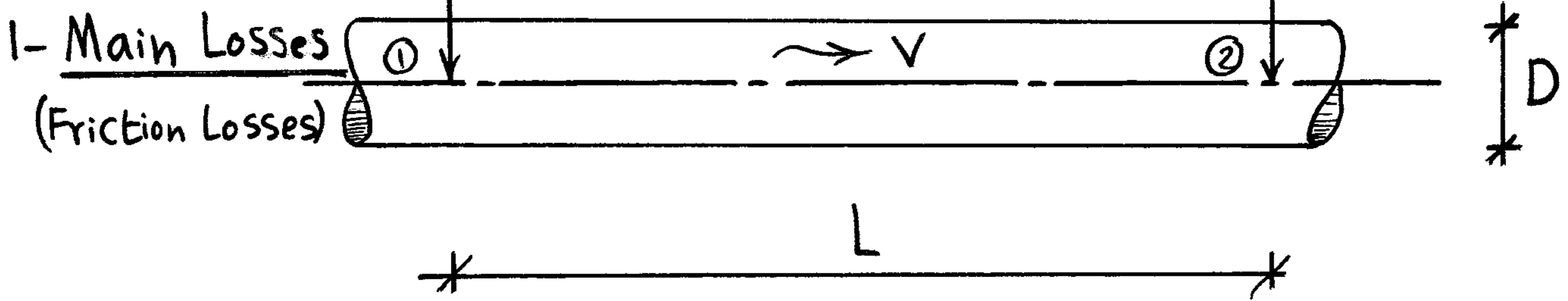

في حالة وجود Friction فإن ال T.E.L يقل تدريجياً مع طول الاحتكاك

$$h_{L(1 \rightarrow 2)} = \frac{FL}{d} \left( \frac{V^2}{2g} \right) = K \frac{V^2}{2g}$$

## 2- Secondary Losses (Minor-Local) losses

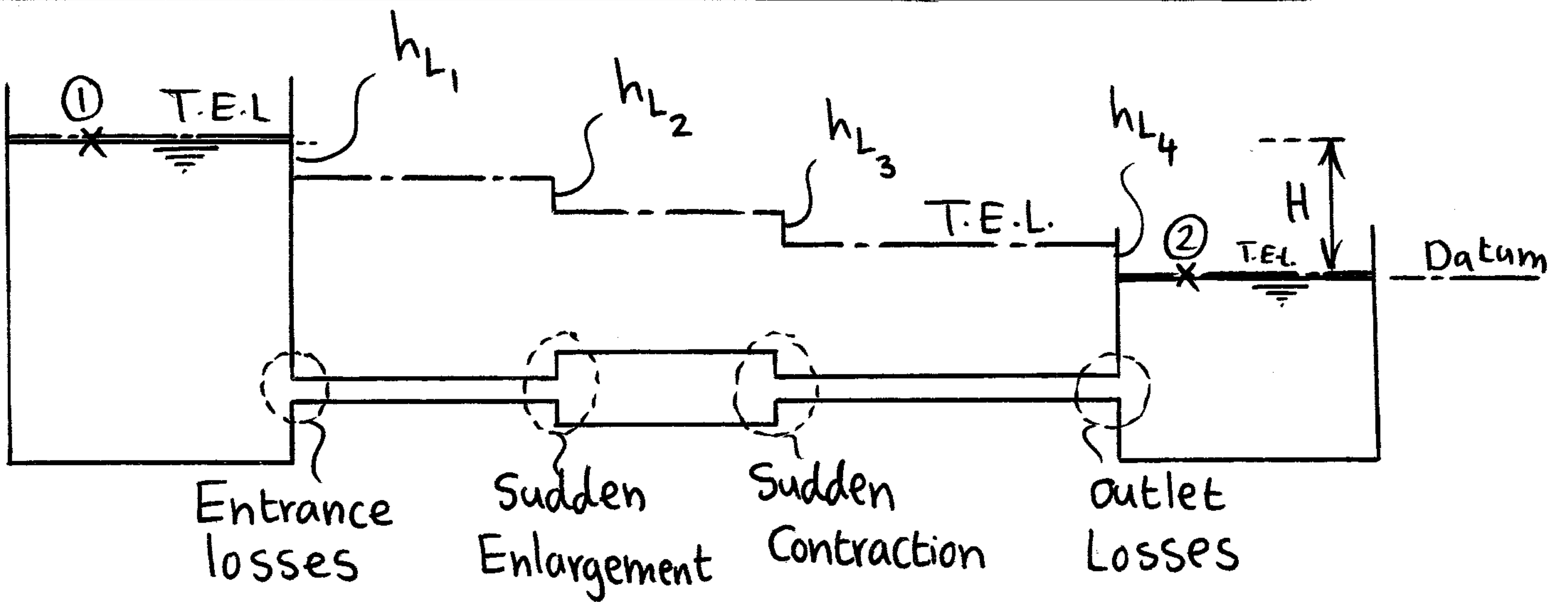

$$\Sigma h_L = h_{L1} + h_{L2} + h_{L3} + h_{L4}$$

Apply Bernoulli between ①, ②

$$\frac{P_1}{\rho} + \frac{V_1^2}{2g} + z_1 = \frac{P_2}{\rho} + \frac{V_2^2}{2g} + z_2 + \Sigma h_L$$

$\angle_{=0}$     $\angle_{\approx 0}$     $\angle_{=0}$     $\angle_{\approx 0}$     $\angle_{=0}$

$$H = \Sigma h_L$$

## Pumps (Adds energy to the System) (14)

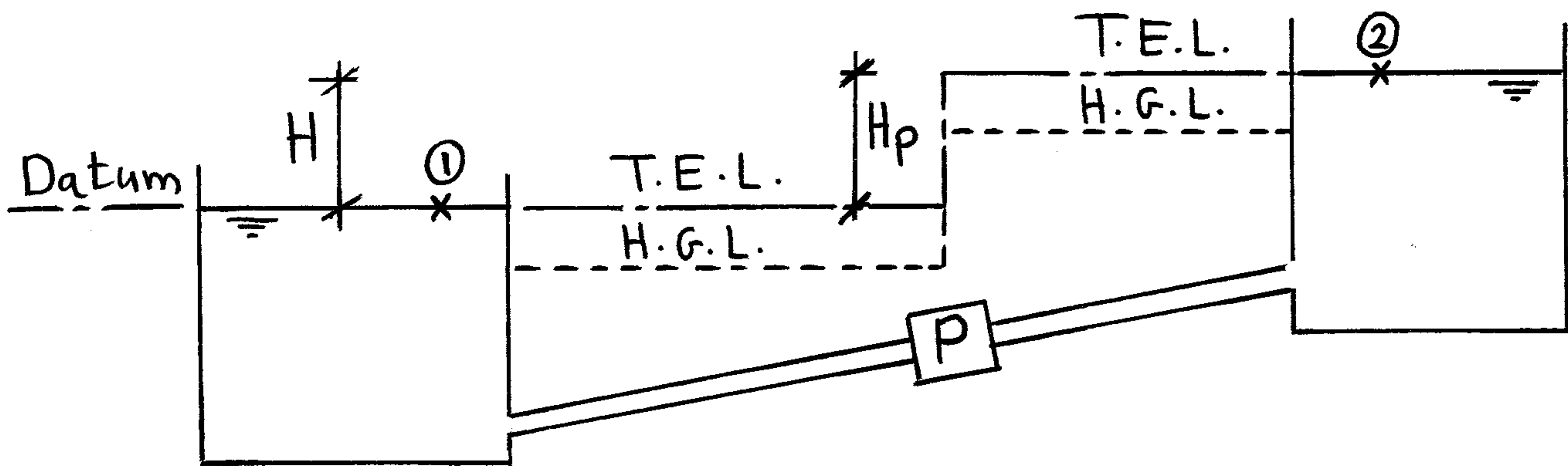

Applying Bernoulli eqn between ①, ②

$$\frac{P_1}{\rho} + \frac{V_1^2}{2g} + Z_1 + H_p = \frac{P_2}{\rho} + \frac{V_2^2}{2g} + Z_2$$

$\underbrace{\quad}_{\approx 0} \quad \underbrace{\quad}_{\approx 0} \quad \underbrace{\quad}_{=0} \quad \underbrace{\quad}_{=0} \quad \underbrace{\quad}_{\approx 0}$

$$H_p = H$$

تعمل ال Pump على إضافة طاقة Energy إلى ال System وبالتالي يزيد ال T.E.L. كما يزيد ال H.G.L.

## Turbines (Extracts energy from the System)

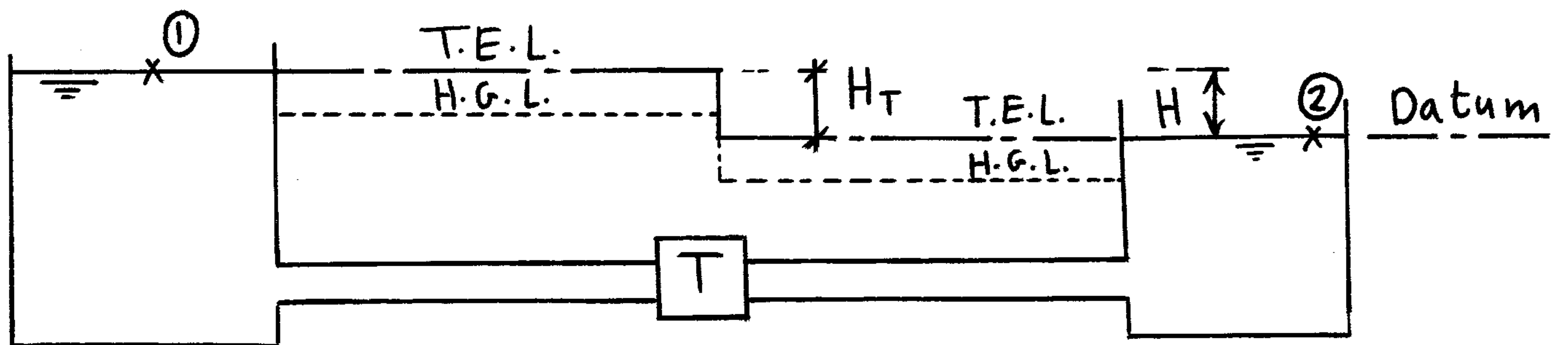

Applying Bernoulli eqn between ①, ②

$$\frac{P_1}{\rho} + \frac{V_1^2}{2g} + Z_1 - H_T = \frac{P_2}{\rho} + \frac{V_2^2}{2g} + Z_2$$

$$H = H_T$$

تعمل ال Turbine على استخراج طاقة Energy من ال System

وبالتالي يقل ال T.E.L. كما يقل ال H.G.L.

# Bernoulli's General equation

(15)

Energy + Energy - Energy - Energy = Energy  
at A added lost Extracted at B

$$\left( \frac{P_A}{\gamma} + \frac{V_A^2}{2g} + Z_A \right) + H_p - \sum H_L - H_T = \left( \frac{P_B}{\gamma} + \frac{V_B^2}{2g} + Z_B \right)$$

## طريقة حل مسائل Bernoulli

- 1- يتم رسم المألة واختيار Datum لكل equation ويفضل أن يكون اختيار ال Datum عند أقل منسوب لتجنب الاشارات السالبة
- 2- تطبيق Bernoulli بين النقطتين في نفس المسائل
- 3- لو لم تكن السرعة معلومة يتم عمل علاقة تربط بينهما  $V_1$  و  $V_2$  عن طريق قانونه ال Continuity  $Q = A_1 V_1 = A_2 V_2$
- 4- يتم طرح أي losses
- 5- يتم طرح أي head ناتج عن وجود Turbine
- 6- يتم زيادة أي head ناتج عن وجود Pump

## Notes

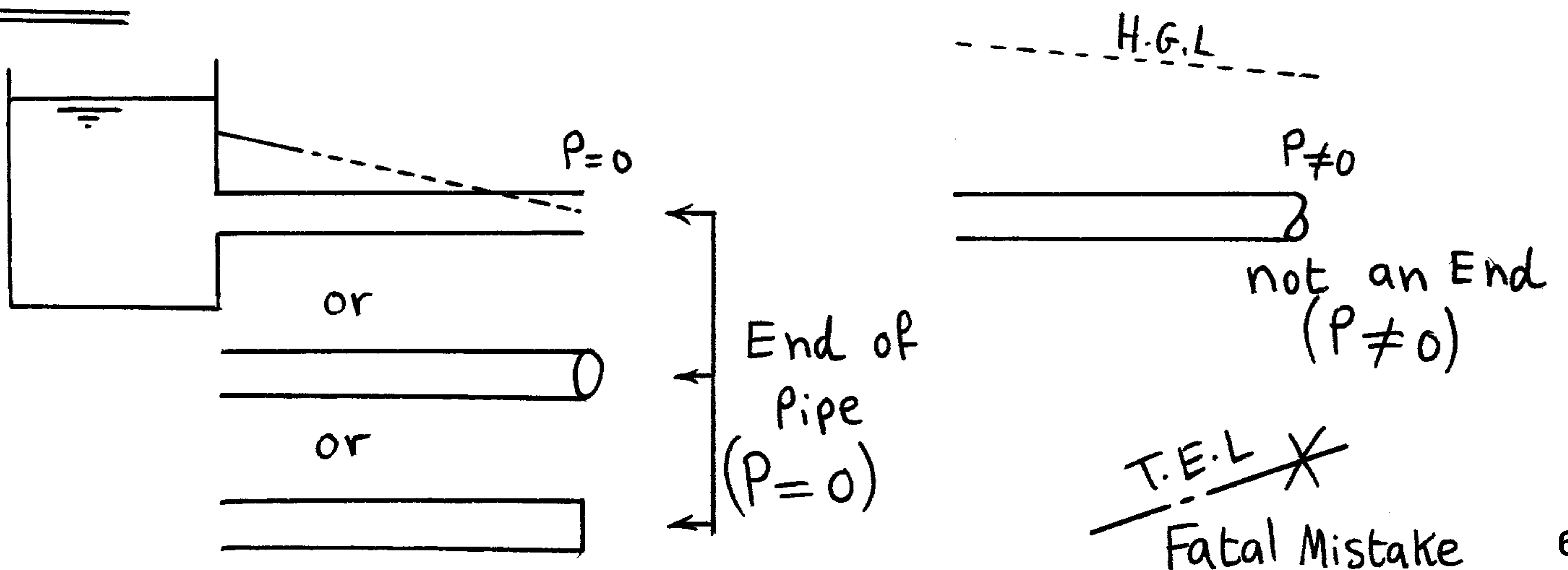



Higher Technological Institute  
Civil Engineering Department



Sheets of  
**Fluid Mechanics**

Dr. Amir M. Mobasher

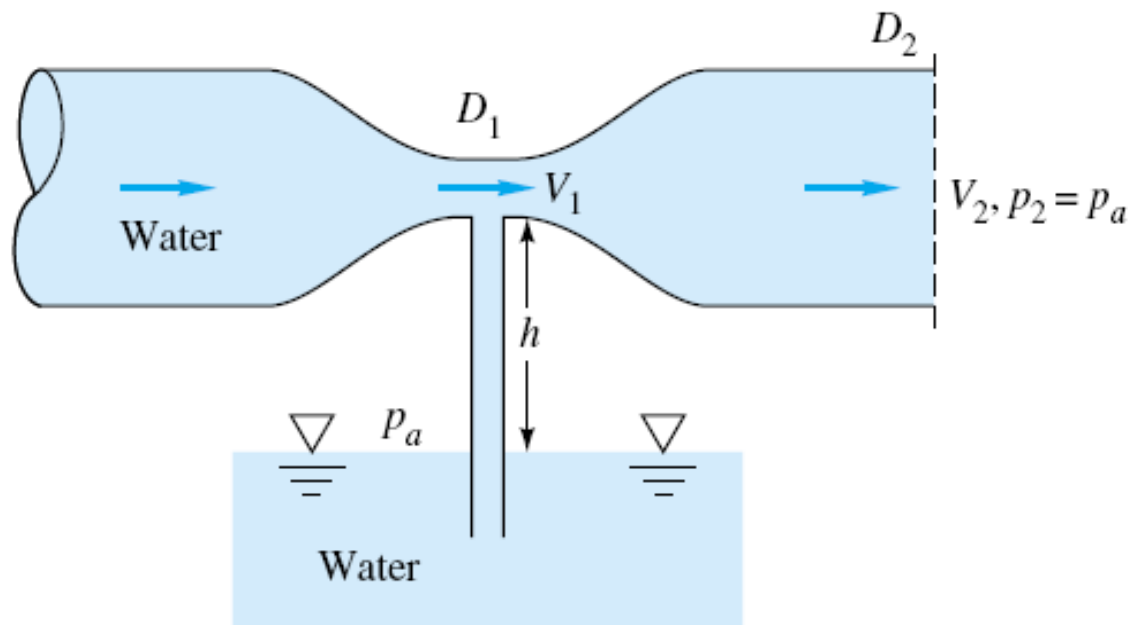

## Sheet (1) - Units and Dimensions

**Q1:** Using dimensional analysis, put down the dimensions and units in the engineering systems {pound (lb), foot (ft), second (s)} and {kilogram (kg), meter (m), second (s)} for the following engineering quantities:

- Density ( $\rho$ ), specific weight ( $\gamma$ ), surface tension ( $\sigma$ ), pressure intensity ( $p$ ), dynamic viscosity ( $\mu$ ), kinematic viscosity ( $\nu$ ), energy per unit weight, power, liner momentum, angular momentum, shear stress ( $\tau$ ).

**Q2:** Show that the following terms are dimensionless:

$$\frac{v \cdot y}{\nu}, \frac{\rho \cdot v \cdot y}{\mu}, \frac{v}{\sqrt{g \cdot y}}, \frac{p}{\rho \cdot v^2}, \frac{L \cdot v^2}{h \cdot g \cdot d}$$

**Q3:** Find the dimensions for the following terms:

$$\frac{v^2}{g}, \frac{p}{\gamma}, \rho \cdot v^2, \gamma \cdot y, \frac{dp}{dx}, \frac{\tau}{y}, \rho \cdot Q \cdot v, \gamma \cdot Q \cdot L$$

**Q4:** Convert the following terms:

- |                                    |    |   |
|------------------------------------|----|---|
| • $\gamma = 1000 \text{ kg/m}^3$   | to | $\text{lb/ft}^3$  |
| • $g = 9.81 \text{ m/sec}^2$       | to | $\text{ft/sec}^2$   |
| • $p = 7 \text{ kg/cm}^2$          | to | $\text{N/m}^2$  |
| • $\gamma = 710 \text{ dyne/cm}^3$ | to | $\text{lb/ft}^3, \text{N/m}^3$                            |
| • $\mu = 4640.84 \text{ poise}$    | to | $\text{lb}\cdot\text{sec/ft}^2, \text{Pa}\cdot\text{sec}$ |

## Sheet (2) – Fluid Properties

- Q1:** What is the diameter of a spherical water drop if the inside pressure is 15 N/m<sup>2</sup> and the surface tension is 0.074 N/m.
- Q2:** The pressure within a bubble of soapy water of 0.05 cm diameter is 5.75 gm/cm<sup>2</sup> greater than that of the atmosphere. Calculate the surface tension in the soapy water in S.I. units.
- Q3:** Calculate the capillary effect in millimeters in a glass tube of 4 mm diam., when immersed in (i) water and (ii) in mercury. The temperature of liquid is 20° C and the values of surface tension of water and mercury at this temperature in contact with air are 0.0075 kg/m and 0.052 kg/m respectively. The contact angle for water = 0 and for mercury = 130°.
- Q4:** To what height will water rise in a glass tube if its diameter is (σ = 0.072 N/m)  
a) 1.50 cm                                      b) 2.0 mm
- Q5:** The space between a square smooth flat plate (50 x 50) cm<sup>2</sup>, and a smooth inclined plane (1:100) is filled with an oil film (S.G. = 0.9) of 0.01 cm thickness. Determine the kinematic viscosity in stokes if the plate is 2.3 kg. The velocity of the plate = 9 cm/sec.

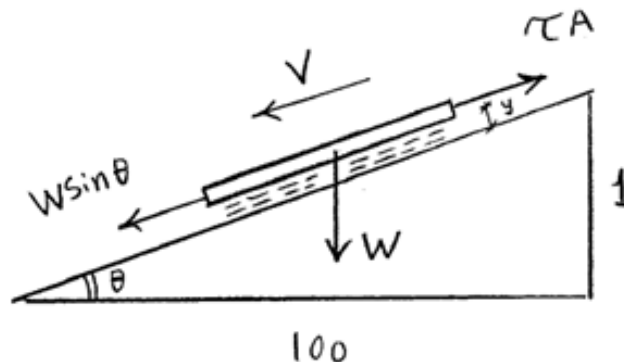

**Q6:** For the shown figure, Calculate the friction force if the plate area is (2m x3m) and the viscosity is 0.07 poise.

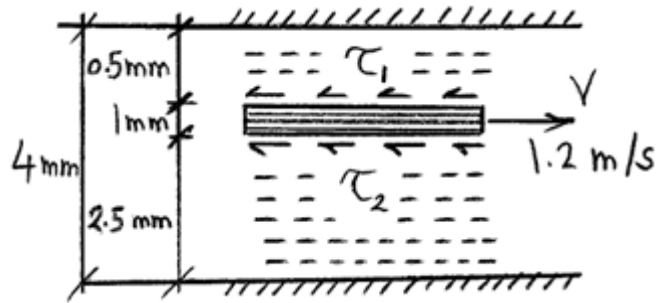

**Q7:** A piston 11.96 cm diameter and 14 cm long works in a cylinder 12 cm diameter. A lubricating oil which fills the space between them has a viscosity 0.65 poise. Calculate the speed at which the piston will move through the cylinder when an axial load of 0.86 kg is applied. Neglect the inertia of the piston.

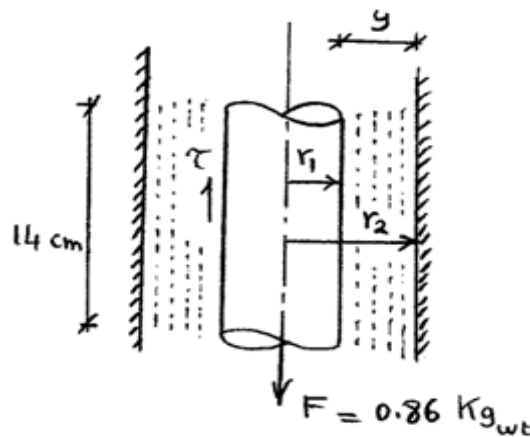

**Q8:** A piece of pipe 30 cm long weighting 1.5 kg and having internal diameter of 5.125 cm is slipped over a vertical shaft 5.0 cm in diameter and allowed to fall under its own weight. Calculate the maximum velocity attained by the falling pipe if a film of oil having viscosity equals 0.5 lb.s/ft<sup>2</sup> is maintained between the pipe and the shaft.

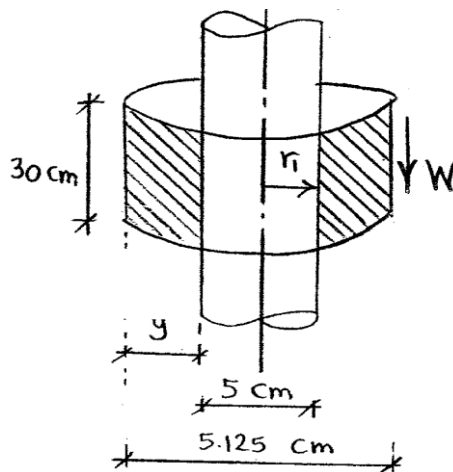

**Q9:** A cylinder of 0.12 m radius rotates concentrically inside of a fixed cylinder of 0.122 m radius. Both cylinders are 0.30 m long. Determine the viscosity of the liquid which fills the space between the cylinders if a torque of 1 N.m is required to maintain an angular velocity of 2 rad/s.

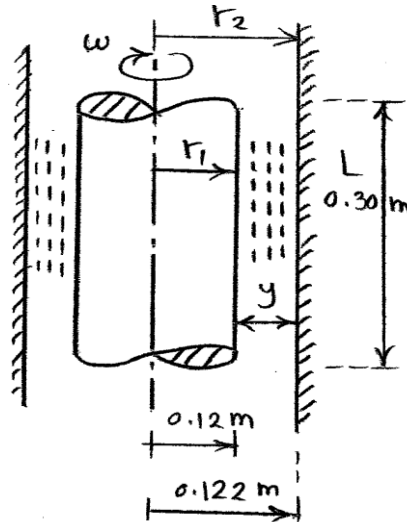

**Q10:** The thrust of a shaft is taken by a collar bearing provided with a forced lubrication system. The lubrication system maintains a film of oil of uniform thickness between the surface of the collar and the bearing. The external and internal diameters of collar are 16 and 12 cms. respectively. The thickness of oil film is 0.02 cms. and coefficient of viscosity is 0.91 poise. Find the horse-power lost in overcoming friction when the shaft is rotated at a speed of 350 r.p.m.

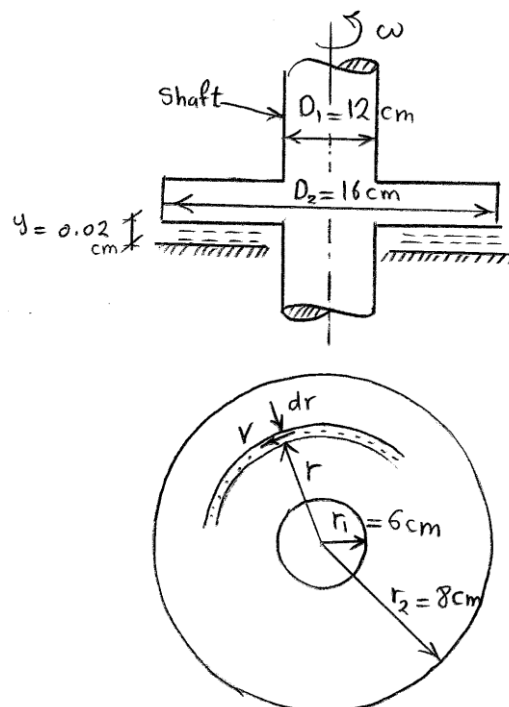

Sheet (3) – Hydrostatic Pressure

**Q1:** A tank full of water as shown below. Find the maximum pressure, and h.

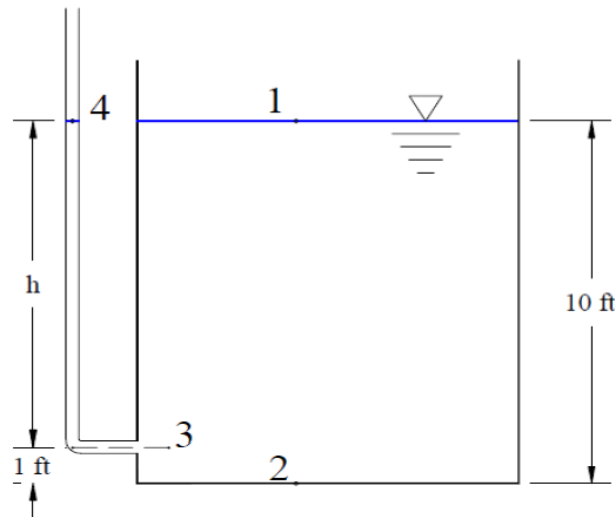

**Q2:** A tank full of water and oil (S.G = 0.80), as shown. Find the pressure at the oil/water interface and the bottom of the tank.

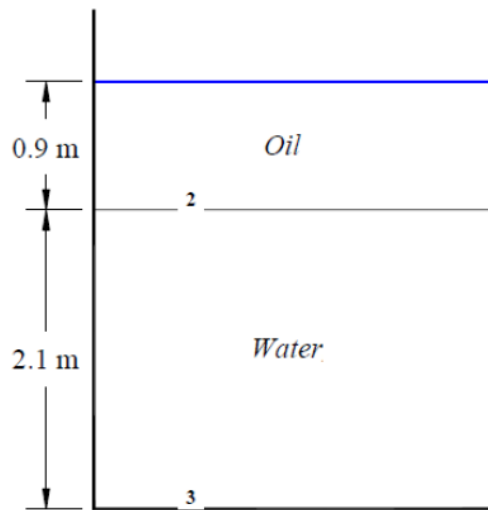

**Q3:** For the shown figure, find the pressure ( $P_1$ ) if the pressure ( $P_2$ ) = 60 KPa (abs)?

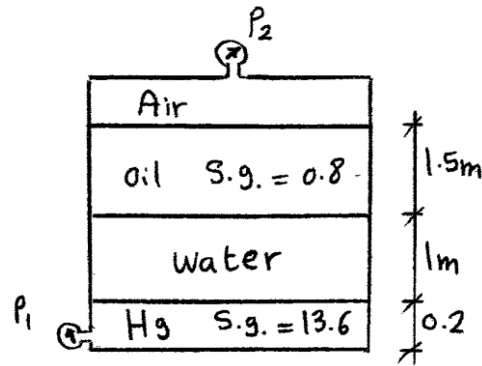

**Q4:** If the pressure at point (B) = 300 KPa as shown in figure, find the followings:  
 a) The height ( $h$ )      b) The pressure at point (A)?

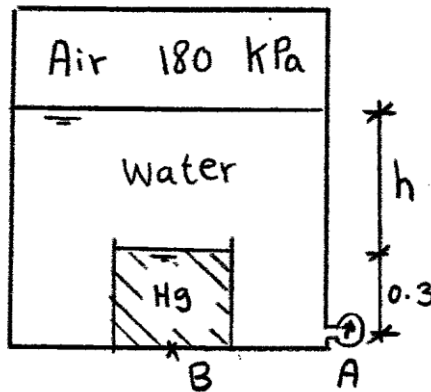

**Q5:** For the shown figure, find the height ( $h$ )?

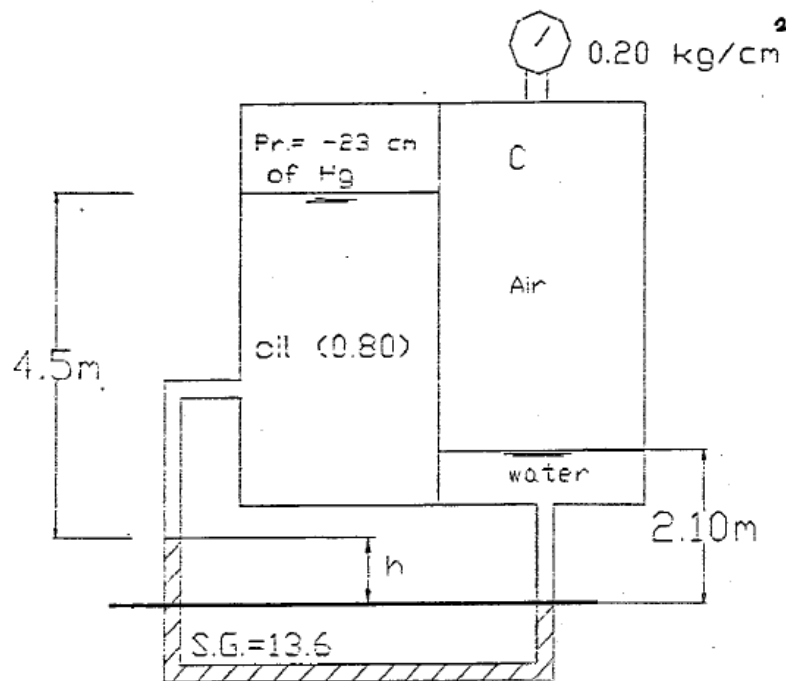

**Q6:** For the shown figure, where is the maximum pressure ( $P_{AB}$  or  $P_{BC}$ )?

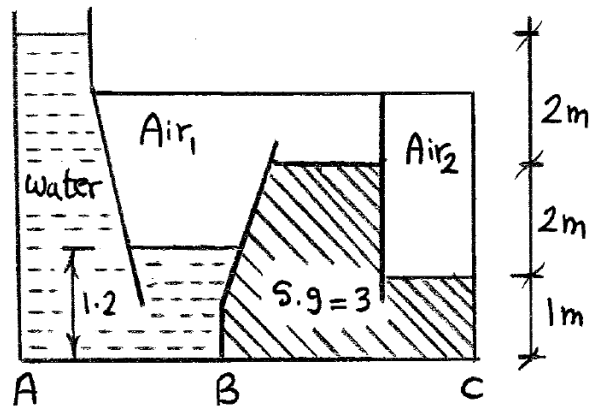

**Q7:** For the shown figure, what is the difference in pressure between points 1,2?

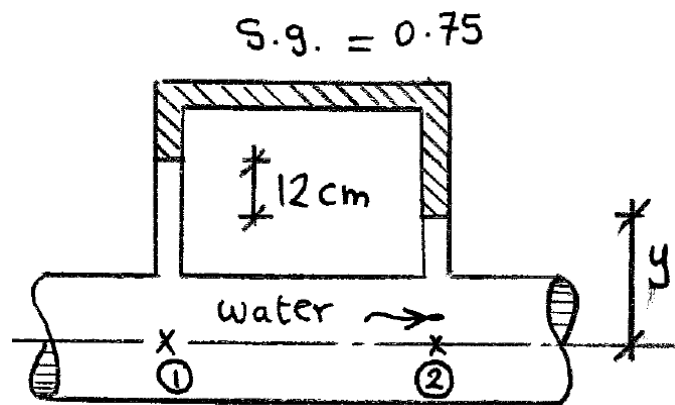

**Q8:** Pressure gage B is to measure the pressure at point A in a water flow. If the pressure at B is  $9 \text{ t/m}^2$ , estimate the pressure at A.

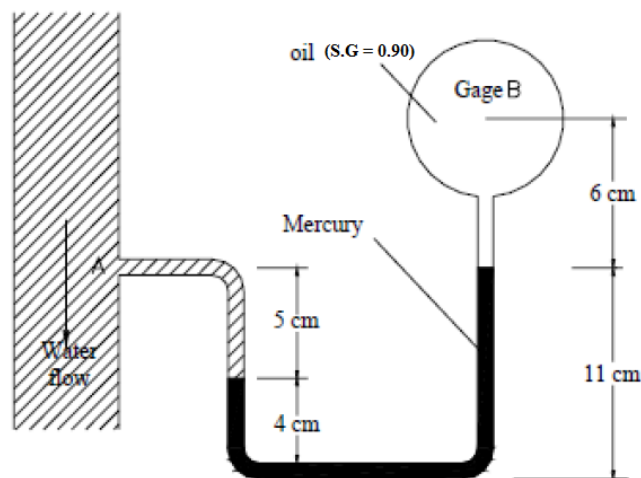



**Q9:** For the shown figure, what is the difference in pressure between points A, B?

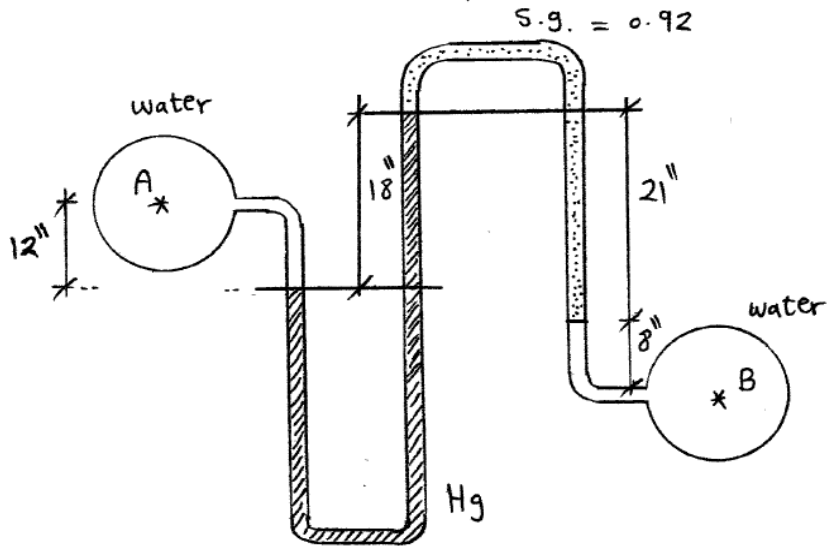

**Q10:** For the shown figure, what is the pressure at gauge dial  $P_g$ ?

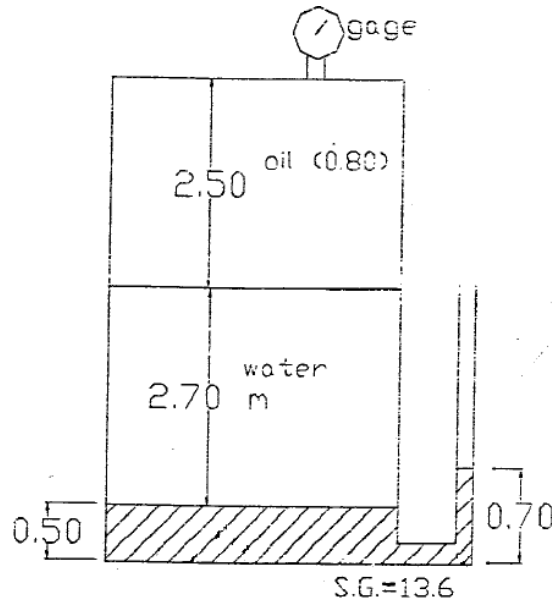

**Q11:** For the shown figure, what is the pressure of air " $P_{air(1)}$ "?

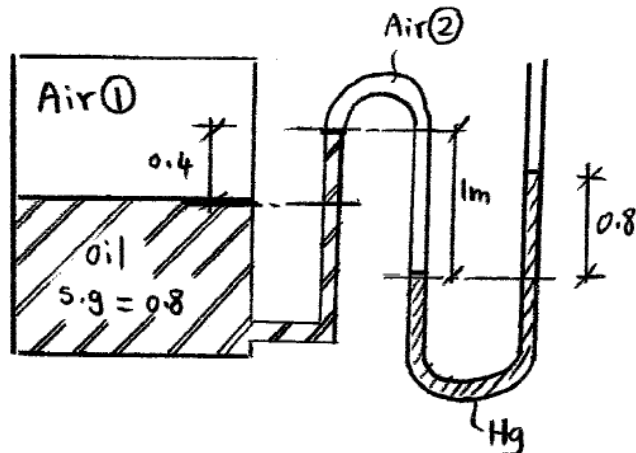

**Q12:** For the configuration shown, Calculate the weight of the piston if the gage pressure is 70 KPa.

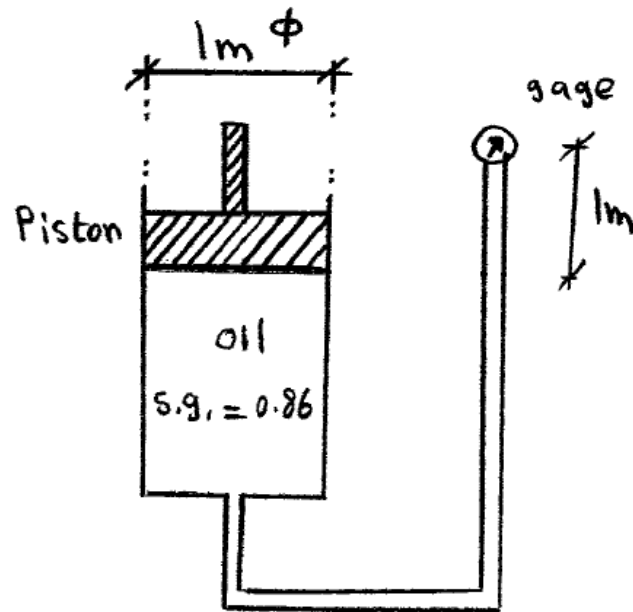

**Q13:** For the shown hydraulic press, find the force (F) required to keep the system in equilibrium.

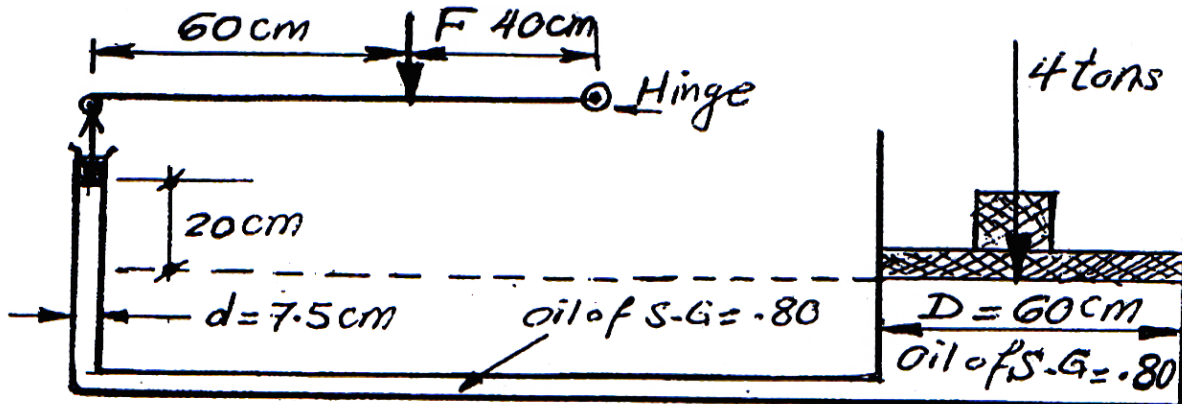

Sheet (4) – Hydrostatic Forces on Surfaces

**Q1:** A vertical triangular gate with water on one side is shown in the figure. Calculate the total resultant force acting on the gate, and locate the center of pressure.

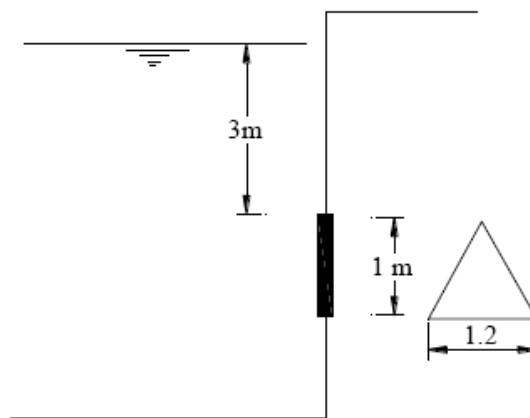

**Q2:** In the shown figure, the gate holding back the oil is 80 cm high by 120 cm long. If it is held in place only along the bottom edge. What is the necessary resisting moment at that edge.

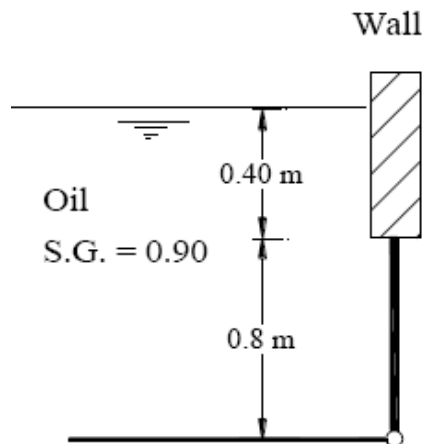

**Q3:** In the shown figure, the gate holding back the water is 6 ft wide. If it is held in place only along the bottom edge. What is the necessary resisting moment at that edge.

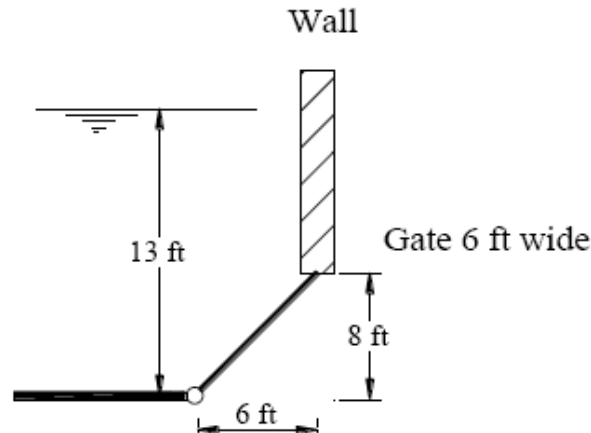

**Q4:** (A) Find the magnitude and line of action of force on each side of the gate.  
 (B) Find the resultant force due to the liquid on both sides of the gate.  
 (C) Determine F to open the gate if it is uniform and weighs 6000 lb.

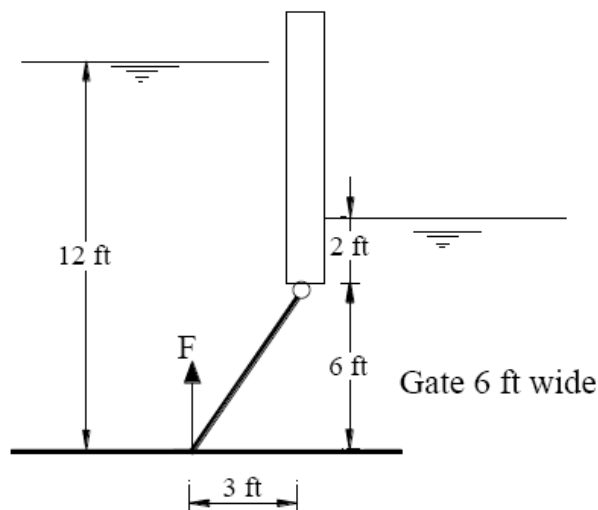

**Q5:** Gate AB in the shown figure, calculate force F on the gate and its acting position X. If the gate is: (a) semi-circle 1.2 radius (b) rectangle 1.2 x 0.8

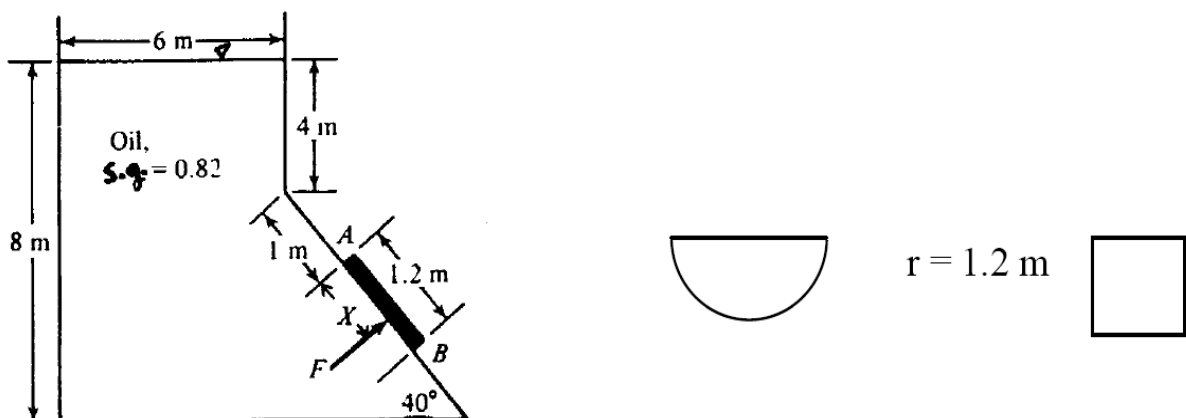

**Q6:** Find the value of “P” which make the gate in the shown figure just rotate clockwise, the gate is 0.80 m wide.

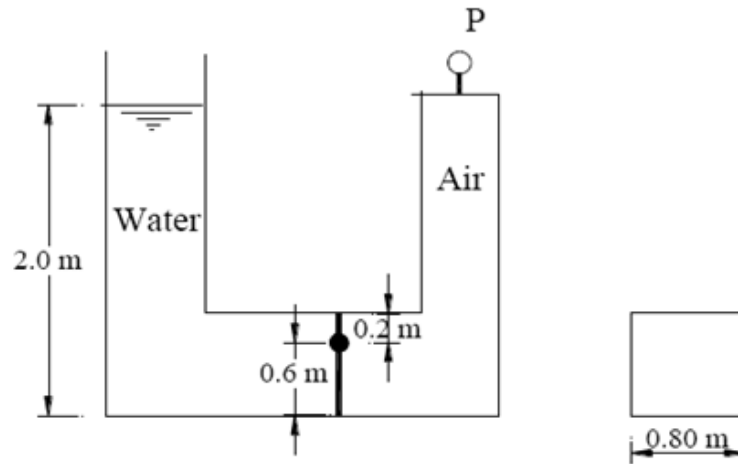

**Q7:** Determine the value and location of the horizontal and vertical components of the force due to water acting on curved surface per 3 meter length.

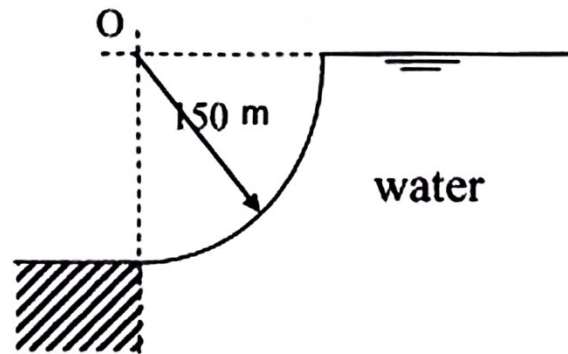

**Q8:** Determine the horizontal and vertical components of the force acting on radial gate ABC in the shown figure and their lines of action. What F is required to open the gate. Take the weight of the gate  $W = 2000$  kg acting on 1m from O?

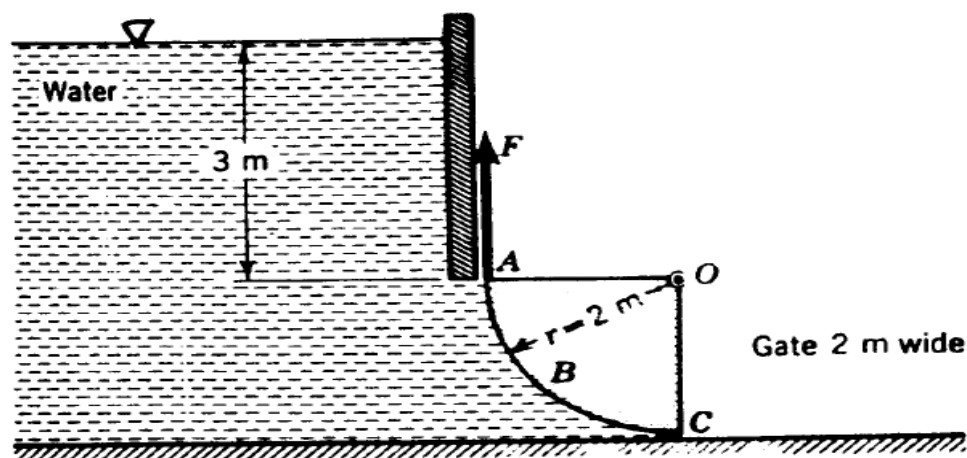

**Q9:** A cylinder barrier (0.30 m) long and (0.60 m) diameter as shown in figure. Determine the magnitude of horizontal and vertical components of the force due to water pressure exerted against the wall.

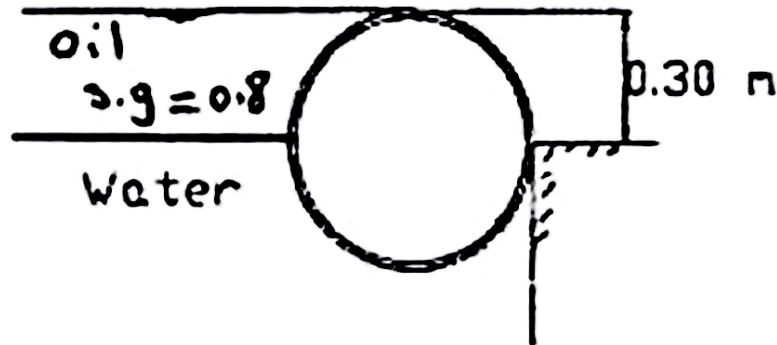

**Q10:** Compute the horizontal and vertical components of the hydrostatic force on the hemispherical dome at the bottom of the shown tank.

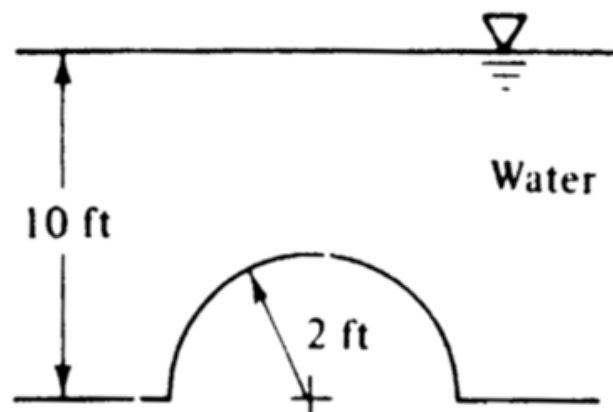

**Q11:** The hemispherical dome in the figure weighs 30 kN, is filled with water, and is attached to the floor by six equally spaced bolts. What is the force on each bolt required to hold the dome down.

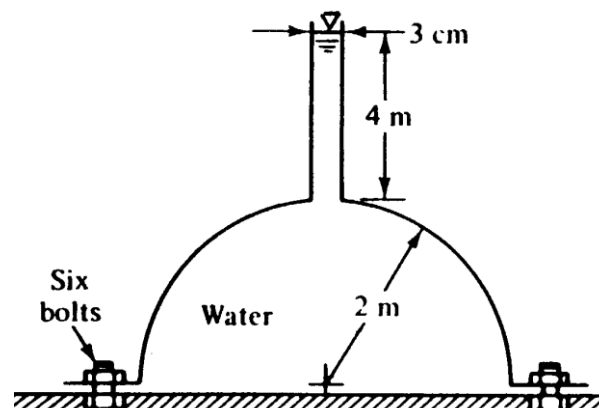

Sheet (5) – Accelerated Fluid Mass

**Q1:** Calculate the total forces on the sides and bottom of the container shown in Figure 1 while at rest and when being accelerated vertically upward at  $3 \text{ m/s}^2$ . The container is  $2.0 \text{ m}$  wide. Repeat your calculations for a downward acceleration of  $6 \text{ m/s}^2$ .

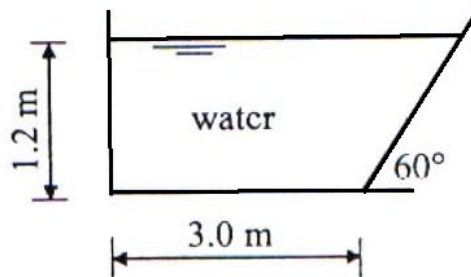

Figure 1

**Q2:** For the shown container in Figure 2, determine the pressure at points A, B, and C if:

- The container moves **vertically** with a constant linear acceleration of  $9.81 \text{ m/s}^2$ .
- The container moves **horizontally** with a constant linear acceleration of  $9.81 \text{ m/s}^2$ .

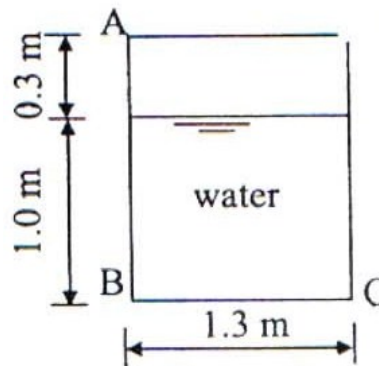
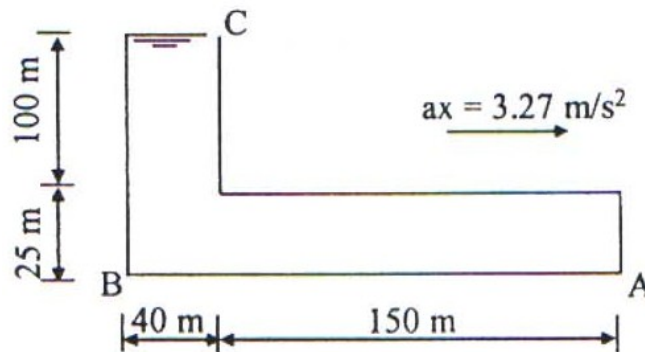

Figure 2

**Q3:** A tank containing water moves horizontally with a constant linear acceleration of  $3.5 \text{ m/s}^2$ . The tank is  $2.5 \text{ m}$  long,  $2.5 \text{ m}$  high and the depth of water when the tank is at rest is  $2.0 \text{ m}$ . Calculate:

- The angle of the water surface to the horizontal.
- The volume of spilled water when the acceleration is increased by 25%.
- The force acting on each side if ( $a_x = 12 \text{ m/s}^2$ ).

**Q4:** A tank containing water moves horizontally with a constant linear acceleration of  $3.27 \text{ m/s}^2$ . The tank is opened at point C as shown in Figure 3. Determine the pressure at points A and B.



**Figure 3**

**Q5:** An open cylindrical tank 2.0 m high and 1.0 m diameter contains 1.5 m of water. If the cylinder rotates about its geometric axis, find the constant angular velocity that can be applied when:

- The water just starts spilling over.
- The point at the center of the base is just uncovered and the percentage of water left in the tank in this case.

**Q6:** An open cylindrical tank 1.9 m high and 0.9 m diameter contains 1.45 m of oil (S.G = 0.9). If the cylinder rotates about its geometric axis,

- What constant angular velocity can be attained without spilling the oil?
- What are the pressure at the center and corner points of the tank bottom when  $(\omega = 0.5 \text{ rad/s})$ .

**Q7:** An open cylindrical tank 2.0 m high and 1.0 m diameter is full of water. If the cylinder is rotated with an angular velocity of 2.5 rev/s, how much of the bottom of the tank is uncovered?

**Q8:** A closed cylindrical container, 0.4 m diameter and 0.8 m high, two third of its height is filled with oil (S.G = 0.85). The container is rotated about its vertical axis. Determine the speed of rotation when:

- The oil just starts touching the lid.
- The point at the center of the base is just clear of oil.



**Q9:** A closed cylindrical tank with the air space subjected to a pressure of 14.8 psi. The tank is 1.9 m high and 0.9 m diameter, contains 1.45 m of oil (S.G = 0.9). If the cylinder rotates about its geometric axis,

- a) When the angular velocity is 10 rad/s, what are the pressure in bar at the center and corner points of the tank bottom.
- b) At what speed must the tank be rotated in order that the center of the bottom has zero depth?

**Q10:** A closed cylindrical tank 2 ft diameter is completely filled with water. If the tank is rotated at 1200 rpm, what increase in pressure would occur at the top of the tank at that case?

## Sheet (6) – Buoyancy & Floatation

- Q1:** Will a beam of S.G. = 0.65 and length 1500 mm long with a cross section 136 mm wide and 96 mm height float in stable equilibrium in water with two sides horizontal?
- Q2:** A floating body 100 m wide and 150 m long has a gross weight of 60,000 ton. Its center of gravity is 0.5 m above the water surface. **Find** the metacentric height and the restoring couple when the body is given a tilt as shown 0.5m.
- Q3:** A ship displacing 1000 ton has a horizontal cross-section at water-line as shown in the figure, its center of buoyancy is 6 ft below water surface and its center of gravity is 1 ft below the water surface. **Determine** its metacentric height for rolling (about y-axis) and for pitching (about x-axis).

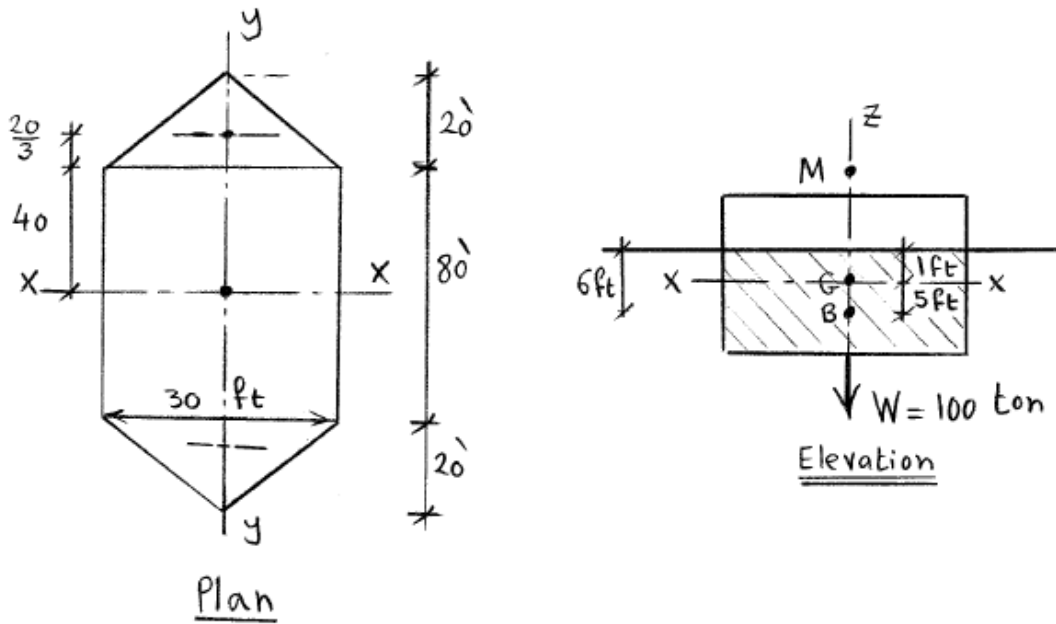

- Q4:** An empty tank rectangular in plan (with all sides closed) is 12.5m long, and its cross section 0.70 m width x 0.60 m height. If the sheet metal weights 363 N/m<sup>2</sup> of the surface, and the tank is allowed to float in fresh water (Specific weight 9.81 KN/m<sup>3</sup>) with the 0.60m wedge vertical. **Show**, whether the tank is stable or not?

**Q5:** A cylindrical buoy 1.8 m diam., 1.2 m high and weighing 10 kN is in sea water of density  $1025 \text{ kg/m}^3$ . Its center of gravity is 0.45 m from the bottom. If a load of 2 kN is placed on the top; find the maximum height of the C.G. of this load above the bottom if the buoy is to remain in stable equilibrium.

**Q6:** A spherical Buoy شمنذورة (floating ball) has a 0.50 m in diameter, weights 500 N, and is anchored to the seafloor with a cable. Although the buoy normally floats on the surface, at certain times the water depth increases so that the buoy is completely immersed. **What is the tension on the cable?**

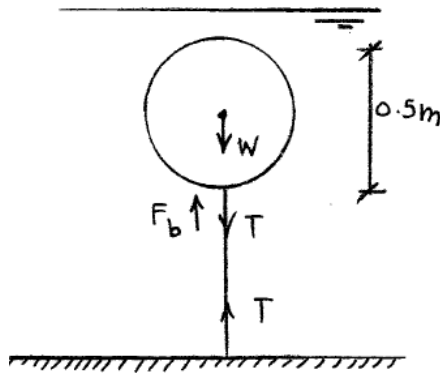

**Q7:** A wooden cylinder 60 cm in diameter, S.G. = 0.50 has a concrete cylinder 60 cm long of the same diameter, S.G. = 2.50, attached to one end. Determine the length of wooden cylinder for the system to float in stable equilibrium with its axis vertical.

**Q8:** A right solid cone with apex angle equal to  $60^\circ$  is of density  $k$  relative to that of the liquid in which it floats with apex downwards. Determine what range of  $k$  is compatible with stable equilibrium.

**Q9:** A cylindrical buoy is 5 feet diameter and 6 feet high. It weighs 1500 lb and its C.G. is 2.5 feet above the base and is on the axis. **Show** that the buoy will not float with its axis vertical in sea water. If one end of a vertical chain is fastened to the centre of the base, **find** the tension in the chain in order that the buoy may just float with its axis vertical.

Sheet (7) – Fundamentals of Fluid Flow

**Q1:** An inclined pipe carrying water gradually changes from 10 cm at A to 40 cm at B which is 5.00 m vertically above A. If the pressure at A and B are respectively 0.70 kg/cm<sup>2</sup> and 0.5 kg/cm<sup>2</sup> and the discharge is 150 liters/sec. Determine a) the direction of flow b) the head loss between the sections.

**Q2:** A cylindrical tank contains air, oil, and water as shown. A pressure of 6 lb/in<sup>2</sup> is maintained on the oil surface. What is the velocity of the water leaving the 1.0-inch diameter pipe (neglect the kinetic energy of the fluids in the tank above elevation A).

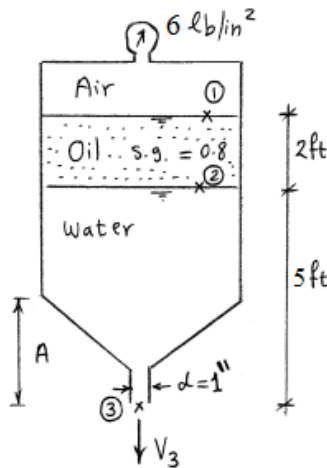

**Q3:** The losses in the shown figure equals  $3(V^2/2g)$ ft, when H is 20 ft. What is the discharge passing in the pipe? Draw the TEL and the HGL.

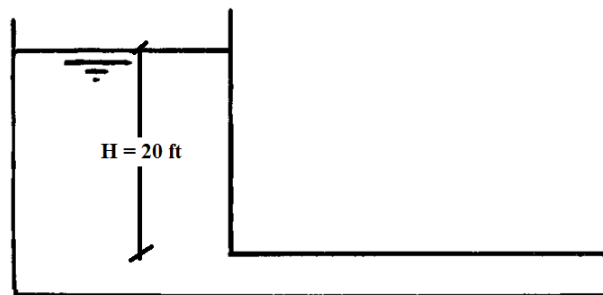

**Q4:** To what height will water rise in tubes A and B? (P = 25 Kpa, Q = 60)

