



# Irrigation Equipment



MALIK RAIHAN RSHIEH

AGRICULTURAL MECHANIZATION DEPARTMENT

TECHNICAL INSTITUTE SHATRAH / SOTHERN TECHNICAL UNIVERSITY

2018-2019



# **Irrigation Equipment**

**Prepare: Eng. Malik Raihan**

**Agricultural Mechanization Department**

**Technical Institute Shatrah / Southern Technical University**

**2018-2019**

## **Irrigation:**

In general the irrigation can be defined that is a providing the water to the soil for supplying it by sufficient moisture which it is important for plant growth.

## **Equipment:**

It is a tool that used to achieve determined purpose or many purposes.

So the irrigation equipment mean: many different tools are used to supply or distribute or rise and convey or control and manage or calculate the irrigation water.

listed many benefits of irrigation as following:

- 1- To supply the plant or crops by water requirements that are necessary for its growth.
- 2- To save the crops from drought periods that may be exposed to it.
- 3- For leaching the salts or to dilute the salt concentration in the roots zone.
- 4- To reduce the hazard of soil surface crust.

5- To ease the different agricultural processes such plowing.

6- To moist the soil and environment to make them more suitable for plant growth.

The importance of irrigation in Iraq:

There are many climatic regions according to the quantity of rain that these regions receive it. These climatic regions can be shown in below Table 1.

Table 1: climatic regions

Climatic regions	Rain quantity mm/year
Arid region	Less than 250
Semi-arid region	250-500
Sub humid region	500-1000
Humid region	1000-1500
Wet region	1500-2000
Very wet region	More than 2000

The most of Iraqi regions be situated in the arid and semi arid region as a result of less quantity of rain that these regions receive it (less than 500mm), so the rain in Iraq falls at winter season only, therefore the irrigation will be very important to supply the different crops by sufficient quantity of water that required for their growth and their production.

### **Irrigation water sources:**

There are many sources of irrigation water , they can be explained by following:

- 1- Surface water: such as river, lakes, bogs,....ets, this source can be regarded the main source in Iraq.
- 2- Under ground water: wells, springs
- 3- Precipitation: such as rain, dew and fog.

In order to study the design of the water transport and distribution system, some simple principles of hydraulics must be taken into account. The hydraulic basis for transporting water in pipes and open channels is almost identical with some minor differences.

---

## **Principle of flow**

There are several types of flow occur in the channels and pipes and each type of laws and its equivalents are:

- 1. Steady Flow:** This is the flow in which the velocity does not change at any point in terms of the amount or direction of time.
- 2. Unsteady Flow:** In which the speed changes at any point in either the amount or direction of time.
- 3. Uniform Flow:** In which the flow velocity does not change either in the amount or direction at a given time for the distance.
- 4. Irregular flow:** in which [the flow speed of the amount or direction at a given time for distance].
- 5. Laminar Flow:** The liquid appears to move in the form of layers without mixing or changes in speed.
- 6. Turbulent Flow:** In which the fluid mixes, the speed and pressure change and its movement is irregular and its path is in the form of curves.

## **Basics of flow:**

The speed of water flow depends mainly on the presence of energy gradient and the difference in energy between two

points. This energy is based on three images: the energy of ground attraction or height, the energy of pressure and the energy of motion. These energies can be transformed from one type to another, This is the first law in thermodynamics (energy conservation law) which states that energy is not destroyed and is not created from nothingness:

**Total energy = kinetic energy + pressure energy + height energy**

$$E_t = (V^2/2g) + (P/W) + Y$$

### **Bernoulli's theory:**

A Swiss scientist who created a theory of fluid movement in 1783, the first to apply the law of conservation of energy to mobile fluids: if the fluid moves from a stream, the total energy of any sector in that course (all points on the course of water movement) remains constant by neglecting friction losses .

Power at (1) = Power at point (2) = Power at point (3) = Constant

### **Bernoulli's Equation**

$\frac{P_s}{\gamma} + Z_s + \frac{V_s^2}{2g} + W - L = \frac{P_d}{\gamma} + Z_d + \frac{V_d^2}{2g}$	<p>g = gravitational constant L = energy losses P<sub>s</sub> = suction pressure P<sub>d</sub> = discharge pressure V<sub>s</sub> = suction velocity V<sub>d</sub> = discharge velocity W = work by the pump Z<sub>s</sub> = suction height from reference Z<sub>d</sub> = discharge head from reference ρ = fluid density γ = fluid specific weight = g*ρ</p>
---	--



## Equation of continuity

For a steady state situation, the mass of fluid going into the tank must be the same as the mass of fluid leaving the tank.

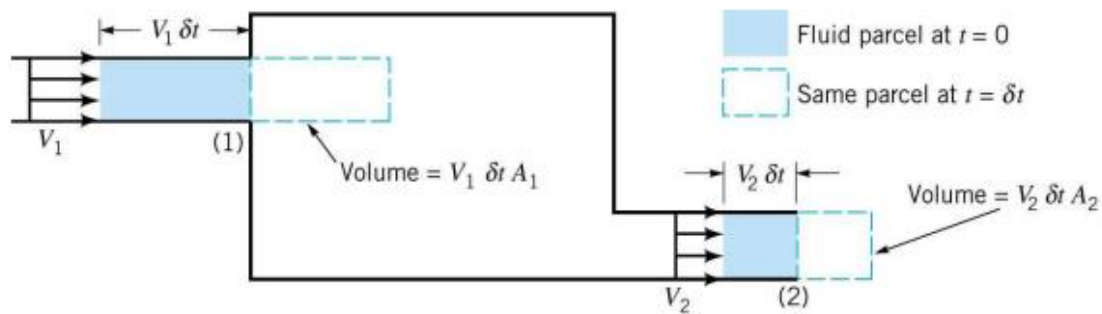

Mass of water in = Mass of water out

$$\rho_1 A_1 v_1 = \rho_2 A_2 v_2$$

This is the continuity equation and for incompressible flow

$$A_1 v_1 = A_2 v_2 \text{ or } Q_1 = Q_2$$

The equation of continuity and the Bernoulli's equation are used into conjunction to analyze many flow situations.

The discharge is defined as the amount of water running in the unit of time through a section of the channel or tube, and its units  $m^3 / s$ ,  $l / s$ ,  $3 \text{ ft} / \text{min}$ .

The discharge is calculated from the continuity equation:

$$Q = A \times V$$

Where:  $Q$  = discharge of water during the water section( $m^3/sec$ )

$A$  = Area of the water section( $m$ )

$V$  = the average velocity of the water through the water section( $m/sec$ )

To design the canals, the hydraulic radius must be depended on.

$$R = A / P$$

Where:

$R$  = hydraulic radius( $m$ )

$A$  = cross section area ( $m^2$ )

$P$  = perimeter contact with water( $m$ )

The common equation that is used to get the velocity of water in opened canals or pipes is manning equation:

$$V = (R^{2/3} * S^{1/2}) / n$$

Where:

$V$  = velocity of water

(m/sec) ,  $R$ =hydraulic radius (m)

$S$ =slope degree of water surface as percentage

$N$ =roughness coefficient

Ex. 1 // canal with cross section area as rectangle shape its width 8 m, the depth of water in it 2m, roughness coefficient 0.025 and the level reading for water surface are 2.5 and 2.6m what is the discharge of this canal?

Solution//

$$Q = A * V$$

$$A = 2 * 8 = 16 \text{ m}^2$$

$$V = (R^{2/3} * S^{1/2}) / n$$

$$R = A / P = 16 / (8 + 2 + 2) = 1.3 \text{ m}$$

$$S = 2.6 - 2.5 = 0.1$$

$$0.1 / 200 = 0.0005$$

$$V = (1.3^{2/3} * 0.0005^{1/2}) / 0.025$$

$$V = 1.065 \text{ m/sec}$$

$$Q = 16 * 1.065$$

$$= 17 \text{ m}^3/\text{sec}$$

Flow rate: Ex.2

Given the water velocity at (2) is 8.0 m/s and the pipe diameter is 0.10 m , what are the volume and mass flow rates?

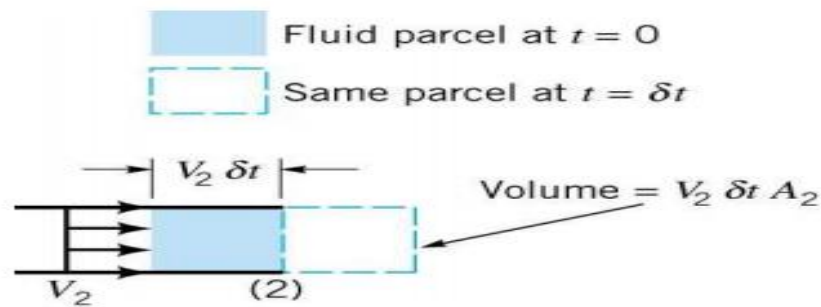

$$Q = vA = v\pi(d/2)^2$$

$$= 8.0 \times \pi(0.050)^2 = 0.06283 \text{ m}^3/\text{s}$$

The mass flow is just  $Q \times \rho$

$$\text{So, } dm / dt = 1000 \times 0.06283 = 62.83 \text{ kg/s}$$

Flow rate: Ex.3

A stream of water  $d = 0.10 \text{ m}$  flows steadily from a tank of diameter  $D = 1.0 \text{ m}$  as shown in the figure. What flowrate is needed from the inlet to maintain a constant water volume in the header tank depth? The depth of water at the outlet is 2.0 m . Can regard outlet as a free jet (note water level at (1) is not going down).

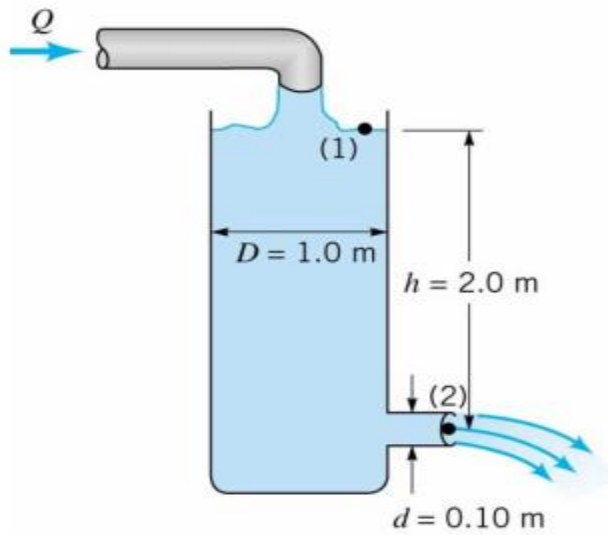

$$v_2 = \sqrt{2gh} = \sqrt{2 \times 9.8 \times 2.0} = 6.26 \text{ m/s}$$

$$\Rightarrow Q_2 = A_2 v_2 = \pi(0.050)^2 6.26 = 0.0492 \text{ m}^3/\text{s} = Q_1$$

The equations used in the flow calculation:

**1. Hazen & Williams equation:**

$$V = 1.32 C_1 R^{0.63} S^{0.54}$$

Where:

V = the rate of velocity feet / s

C1 = friction coefficient

R = Hydraulic radius

S = hydraulic linear regression

## 2. Seoby equation:

$$V = C_s H^{0.5} D^{0.635}$$

Where:

CS =Seoby coefficient

H = Regression (High)

D= pipe diameter

## 3. Manning Equation:

$$V = (0.590/n) D^{(2/3)} S^{(1/2)}$$

Where:

V = speed rate

N = Manning coefficient

D = diameter of the pipe

S = Hydraulic Regression

**4. Darcy-Weisbach equation:** used to calculate loss due to friction.

$$h_l = f (l/D) (V^2/2g)$$

Where:

$h_l$  = loss by friction,  $f$  = coefficient of friction loss

$l$  = distance between two points (cm),  $D$  = diameter of pipe (cm),  $V$  = speed rate (cm / s),  $g$  = Ground acceleration

### Theoretical method

There are many direct and non-theoretical methods for calculating irrigation water measurement:

1- Volumetric Method:

$$\text{Discharge} = \text{container size (l)} / \text{time to fill (s)}$$



2- The raft method:

$$\text{Speed} = \text{distance} / \text{time}$$



---

Lecture 4

### **Soil- water-plant Relationship:**

Classification of soil water as stated earlier, water may occur in the soil pores in varying proportions. Some of the definitions related to the water held in the soil pores are as follows:

- **Gravitational water:** A soil sample saturated with water and left to drain the excess out by gravity holds on to a certain amount of water. The volume of water that could easily drain off is termed as the gravitational water. This



water is not available for plants use as it drains off rapidly from the root zone.

- **Capillary water:** the water content retained in the soil after the gravitational water has drained off from the soil is known as the capillary water. This water is held in the soil by surface tension. Plant roots gradually absorb the capillary water and thus constitute the principle source of water for plant growth.
- **Hygroscopic water:** the water that an oven dry sample of soil absorbs when exposed to moist air is termed as hygroscopic water. It is held as a very thin film over the surface of the soil particles and is under tremendous negative (gauge) pressure. This water is not available to plants.

### **Soil water constants**

For a particular soil, certain soil water proportions are defined which dictate whether the water is available or not for plant growth. These are called the soil water constants, which are described below.

- **Saturation capacity:** this is the total water content of the soil when all the pores of the soil are filled with water. It is also termed as the maximum water holding capacity of the soil. At saturation capacity, the soil moisture tension is almost equal to zero.

- **Field capacity:** this is the water retained by an initially saturated soil against the force of gravity. Hence, as the gravitational water gets drained off from the soil, it is said to reach the field capacity. At field capacity, the macropores of the soil are drained off, but water is retained in the micropores. Though the soil moisture tension at field capacity varies from soil to soil, it is normally between  $1/10$  (for clayey soils) to  $1/3$  (for sandy soils) atmospheres.
- **Permanent wilting point:** plant roots are able to extract water from a soil matrix, which is saturated up to field capacity. However, as the water extraction proceeds, the moisture content diminishes and the negative (gauge) pressure increases. At one point, the plant cannot extract any further water and thus wilts.

Two stages of wilting points are recognized and they are:

1. Temporary wilting point: this denotes the soil water content at which the plant wilts at day time, but recovers during night or when water is added to the soil.
2. Ultimate wilting point: at such a soil water content, the plant wilts and fails to regain life even after addition of water to soil.

### **Quantity of irrigation water**

the quantity of water that is required to irrigate one hectare can be calculated by the following formula:

$$Q=10000*AS*D (PW1-PW2)* 0.5$$

**Where:**

Q=quantity of irrigation water (m<sup>3</sup>/hectar)

As=bulk density (g/cm<sup>3</sup>)

D= depth of root zone(m)

Pw1=moisture percentage at field capacity

Pw2= moisture percentage at permanent wilting point or before irrigation.

**Example-** what is the quantity and the depth of irrigation water that is required to rise soil moisture percentage to the field capacity when moisture percentage at field capacity 25%, soil moisture percentage before irrigation 15%, bulk density of soil 1.4 g/cm<sup>3</sup>, depth of root zone 60 cm and the field area 20 hectares?

Solution:

$$Q=10000*1.4*0.6*(0.25-0.15)*0.5$$

$$=420 \text{ m}^3/\text{hectar}$$

$$420*20=8400\text{m}^3 \text{ for the field}$$

Depth of irrigation water = quantity of irrigation water / irrigation area

$$=8400/20*10000 =0.04\text{m} =4\text{c}$$

## **Irrigation water conveyance**

The irrigation water is conveyed from its sources to the using positions by pipes or canals. These ways are similar hydraulically except the flow or discharge in the pipes depend the pressure and elevation head.

Water may be transported in open channels, pipes, or both. Open channels take up more space and generally have lower conveyance efficiencies. Piped systems required more energy inputs to transfer water.

## **Conveyance System Components**

### Open Channels

- Pipelines
- Conveyance Structures
  - Diversions & Pumps
  - Headgates, Wasteways, Division Boxes, Turnouts ...
  - Water Measurement Devices
  - Check & Grade Control Structures
  - Flumes, Siphons & Culverts

## **Conveyance System of Spray Irrigation**

With sprinkler irrigation, artificial rainfall is created. The water is led to the field through a pipe system in which the water is under pressure. The spraying is accomplished by using several rotating sprinkler heads or spray nozzles or a single gun type sprinkler.

## **Conveyance System of Drip Irrigation**

In drip irrigation, also called trickle irrigation, the water is led to the field through a pipe system. On the field, next to the row of plants or trees, a tube is installed. At regular intervals, near the plants or trees, a hole is made in the tube and equipped with an emitter. The water is supplied slowly, drop by drop, to the plants through these emitters.

## **Pump**

A pump is a device used to move fluids, such as liquids, gases or slurries. A pump displaces a volume by physical or mechanical action. Pumps fall into three major groups: direct lift, displacement, and gravity pumps.

### **Types of pumps:**

Pumps can be classified by their method of displacement into variable displacement pumps and positive displacement pumps.

#### 1. Variable displacement pumps

This type is divided into the following kinds:

A- Centrifugal pumps

a- Turbine pumps

b- Diffuser pumps

c- Volute pumps

B-Mixed flow pumps

C-Axial flow pumps

D- Jet pumps

E-Air lift pumps

## 2. Positive displacement pumps

A- Rotary pumps

B-Reciprocating pumps

---

Lecture 7

### **Pumping principle and pump efficiency**

Low-specific speed radial flow impellers develop hydraulic head principally through centrifugal force. Pumps of higher specific speeds develop head partly by centrifugal force and partly by axial force. An axial flow or propeller pump with a specific speed of 10,000 or greater generates its head exclusively through axial forces. Radial impellers are generally low flow/high head designs whereas axial flow impellers are high flow/low head designs. As the specific speed increases, the ratio of the impeller outlet diameter to the inlet or eye diameter decreases. This ratio becomes 1.0 for a true axial flow impeller.

$$N_s = \frac{N \sqrt{Q}}{H^{3/4}}$$

$$N_s = \frac{N \cdot (Q)^{\frac{1}{2}}}{H^{\frac{3}{4}}}$$

**where:**

**NS** is specific speed (dimensionless)

**N** is pump rotational speed (rpm)

**Q** is flow rate (l/s) at the point of best efficiency ( $m^3/s$ )

**H** is total head (m) per stage at the point of best efficiency

Any changes in the rotary speed makes changes in the discharge, pumping head and break horse power as following:

$$Q = Q (n/n_1)$$

$$H = H_1 (n/n_1)^2 \quad ; \quad P = P_1 (n/n_1)^3$$

$\frac{n}{n_1} = \frac{Q}{Q_1} = \left(\frac{H}{H_1}\right)^{1/2} = \left(\frac{P}{P_1}\right)^{1/3}$
---

Where:

n=required speed rpm

Q=discharge at required speed ( L/sec)

H=head at required speed and for discharge (Q)

P=break horse power at n, H and Q

Q1=discharge at speed n1

H1=head at Q1 and n1

P1=break horse power at Q1, H1 and n1



☒ Note that the units used affect the specific speed value in the above equation and consistent units should be used for comparisons. Pump specific speed can be calculated using British gallons or using Metric units ( $\text{m}^3/\text{s}$  or L/s and meters head), changing the values listed above. The following equation gives a dimensionless specific speed.

---

#### Lecture 8

### **Pump material**

Pump material can be of Stainless steel ( SS 316 or SS 304) , cast iron etc. It depend upon the application of pump. In water industry, SS 316 is normally used. As at high temperature stainless steel give better result.

### **Pumping power:**

The power imparted into a fluid will increase the energy of the fluid per unit volume. Thus the power relationship is between the conversion of the mechanical energy of the pump mechanism and the fluid elements within the pump. However

a more simple Bernoulli's equation can be used. Hence the power,  $P$ , required by the pump:

$$P_f = \dot{m}\Delta h$$

Where:

$P_f$  = pumping power

$\dot{m}$  = volumetric flow rate

$\Delta h$  = change in head

### **Pump efficiency**

Pump efficiency is defined as the ratio of the power imparted on the fluid by the pump in relation to the power supplied to drive the pump. Its value is not fixed for a given pump, efficiency is a function of the discharge and therefore also operating head. For centrifugal pumps, the efficiency tends to increase with flow rate up to a point midway through the operating range (peak efficiency) and then declines as flow rates rise further. Pump performance data such as this is usually supplied by the manufacturer before pump selection.

Pump efficiency,  $\eta$  (%) is a measure of the efficiency with which the pump transfers useful work to the fluid.

$$\eta = P_{\text{out}} / P_{\text{in}} \quad (2)$$

**where:**

$\eta$  = efficiency (%)

$P_{in}$  = power input

$P_{out}$  = power output

✓ **Centrifugal Pumps:**

Almost all irrigation pumps fall into this category. A centrifugal pump uses an “impeller” to spin the water rapidly inside a “casing”, “chamber”, or “housing” (any of those terms may be used.) This spinning action moves the water through the pump by means of centrifugal force.

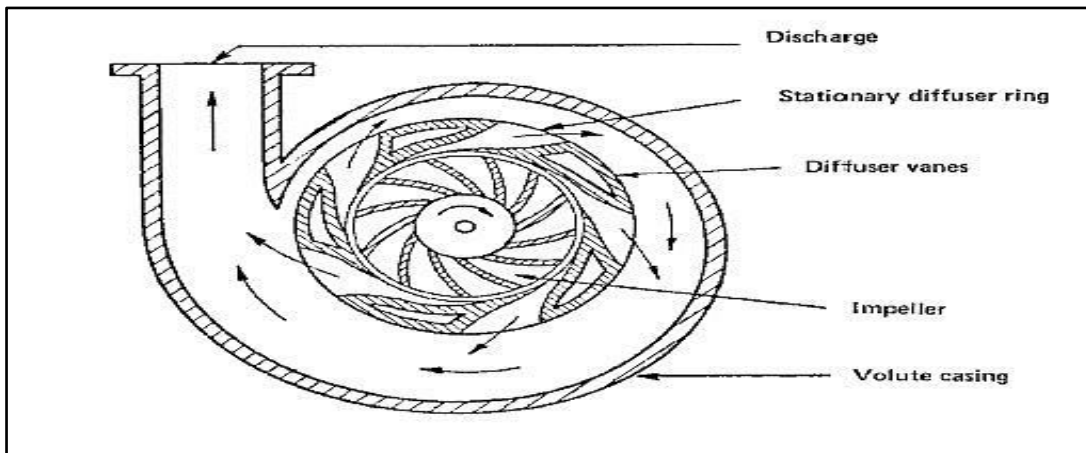
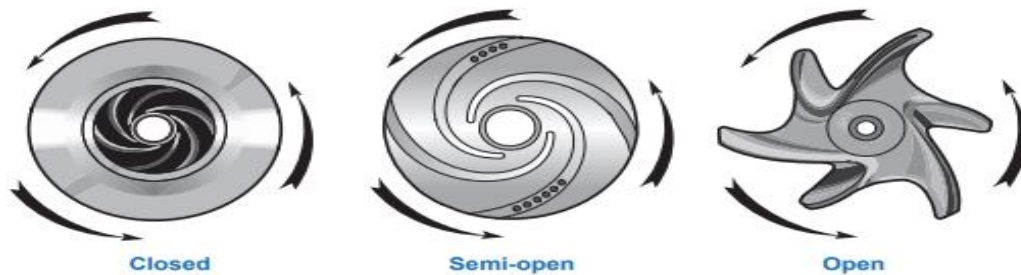

## Figure: centrifugal pump

### **Pressure and Head**

If the discharge of a centrifugal pump is pointed straight up into the air the fluid will be pumped to a certain height - or head - called the shut off head. This maximum head is mainly determined by the outside diameter of the pump's impeller and the speed of the rotating shaft. The head will change as the capacity of the pump is altered.

The kinetic energy of a liquid coming out of an impeller is obstructed by creating a resistance in the flow. The first resistance is created by the pump casing which catches the liquid and slows it down. When the liquid slows down the kinetic energy is converted to pressure energy.

- it is the resistance to the pump's flow that is read on a pressure gauge attached to the discharge line

A pump does not create pressure, it only creates flow. The gauge pressure is a measurement of the resistance to flow.

In fluids the term **head** is used to measure the kinetic energy which a pump creates. Head is a measurement of the height of the liquid column the pump could create from the kinetic energy the pump gives to the liquid.

- the main reason for using head instead of pressure to measure a centrifugal pump's energy is that the pressure from a pump will change if the specific gravity (weight) of the liquid changes, but the head will not

The pump's performance on any Newtonian fluid can always be described by using the term head.

### **Different Types of Pump Head**

- Total Static Head - Total head when the pump is not running
- Total Dynamic Head (Total System Head) - Total head when the pump is running.
- Static Suction Head - Head on the suction side, with pump off, if the head is higher than the pump impeller.
- Static Suction Lift - Head on the suction side, with pump off, if the head is lower than the pump impeller.
- Static Discharge Head - Head on discharge side of pump with the pump off.
- Dynamic Suction Head/Lift - Head on suction side of pump with pump on
- Dynamic Discharge Head - Head on discharge side of pump with pump on

The head is measured in either feet or meters and can be converted to common units for pressure - like psi, Pa or bar.

- it is important to understand that the pump will pump all fluids to the same height if the shaft is turning at the same rpm

The only difference between the fluids is the amount of power it takes to get the shaft to the proper rpm. The higher the specific gravity of the fluid the more power is required.

- Centrifugal Pumps are "**constant head machines**"

Note that the latter is not a constant pressure machine, since pressure is a function of head and density. The head is constant, even if the density (and therefore pressure) changes.

The head of a pump can be expressed in metric units as:

$$h = (p_2 - p_1) / (\rho g) + v_2^2 / (2g)$$

where:

$h$  = total head developed (m)

$p_2$  = pressure at outlet (N/m<sup>2</sup>)

$p_1$  = pressure at inlet ( $\text{N/m}^2$ )

$\rho$  = density ( $\text{kg/m}^3$ )

$g$  = acceleration of gravity ( $9.81$ )  $\text{m/s}^2$

$v_2$  = velocity at the outlet ( $\text{m/s}$ )

## Turbine pump

Turbine pumps are special types of centrifugal pumps which use turbine-like impellers with radially oriented teeth to move fluid. They are also referred to as vortex, periphery, or regenerative pumps. These pumps combine the high discharge pressures of positive displacement or multi-stage centrifugal pumps with the flexible operation of centrifugal pumps. Additionally, the flow rate of turbine pumps is not extremely variable with large changes in pressure like in most centrifugal pumps. They are preferred in applications where high head, low flow, and compact design are desired, such as in deep-well pumping.

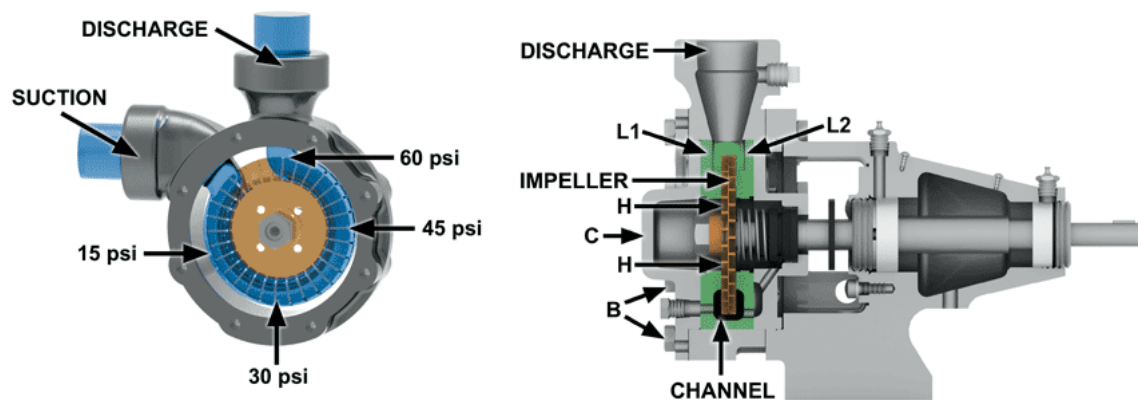

## **Advantages**

- Generates high head and high discharge pressure
- Better handling of gas-liquid mixtures
- Flow rate less variable with pressure change
- Compact design

## **Disadvantages**

- Low flow rate
- Tight internal clearances require clean (no-solids) liquids
- Particularly susceptible to damage from improper assembly
- No easy way to adjust performance

## **Features**

Designs and features of turbine pumps provide different facets of capability and functionality that may be important to consider.

- **Balanced impellers** - Turbine pumps with balanced or floating impellers generate very little axial thrust on the motor shaft, promoting longer bearing life.



- Close-coupled - Close-coupled pumps have the pump end mounted directly on the motor shaft for a more compact design.
- Double-sided impellers - Double-sided impeller design helps to reduce impeller wear by building pressure equally on both sides and creating a thin fluid film between the impeller and casing. This film also causes the impeller to self-adjust to its optimum axial position. (Double sided design shown right - Image Credit: Lytron)
- Multi-stage - Multi-stage turbine pumps move the compressed fluid through multiple successive chambers or stages of pressurization. While most turbine pumps are single stage (one impeller and chamber) because of their high head impeller design, some implement multiple stages to generate even higher pressure levels.
- Thermal overload protection - Some pump motors include devices which will shut the pump off if the motor becomes too hot or exceeds a certain temperature.
- Self-priming - Certain turbine pumps may be design for self-priming or sealless operation, meaning they are constructed so they can create and maintain a sufficient

vacuum level to draw fluid into the inlet with no external assistance.

- **Submersible** - The motor on a turbine pump is typically above the liquid level, but some can be designed to be submerged in the media on a shorter drive shaft.
- **Vertical orientation** - Turbine pumps with a vertical orientation, also called deep well pumps, are designed to pump media vertically through the pump body. They are specially designed for pumping water from deep water sources such as wells, and are mainly used over other types of pumps in applications where the water surface fluctuates regularly.

## **Applications**

Turbine pumps are used in clean liquid applications that demand high head, low flow, compact design, and flexible operation. They're used in a wide range of industrial applications such as cooling water circulators for lasers and other machines where high head is required. Turbine pumps are also found in small boiler feed services in bakeries, dry cleaners, breweries, and other commercial plants.

## **Mixed Flow Pump**

The energy efficient and reliable mixed flow pumps function as a compromise between radial and axial flow pumps. They operate at higher pressures than axial flow pumps while delivering higher capacities. The pumps are available in both horizontal and vertical configurations.

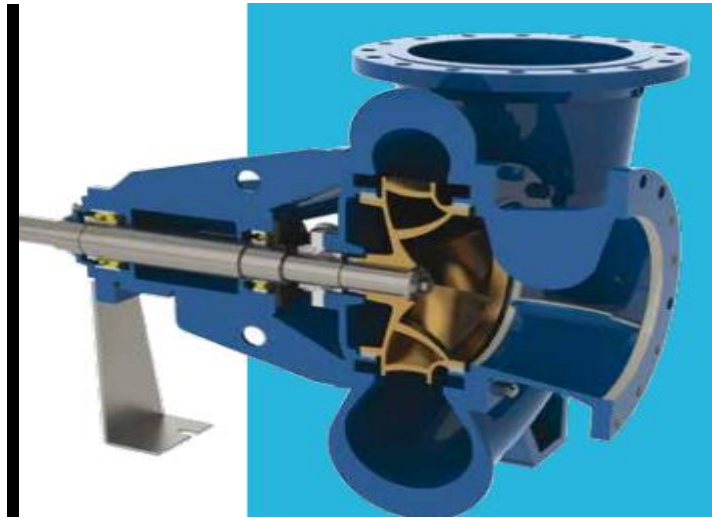

## **Applications**

- Drinking water
- Sewage water
- Cooling water
- Effluent
- Irrigation
- Drainage
- Desalination

## **Features and Benefits**

### **❖ Features**

- Oversized shafts and reduction of the overhang reduces shaft deflection to a minimum. This eliminates shaft failures and increases seal and bearing life.
- For ease of maintenance, the entire rotating assembly can be removed without disturbing the casing or suction and discharge piping.
- Larger mixed flow pumps in sewage systems have specially designed impellers with large ball passages. The replaceable wear rings carry solid matter away from the working face, thus reducing wear and eliminating clogging and jamming.
- Large access holes with contoured covers give easy access to the impeller.

### ❖ **Benefits**

- High efficiencies and reduced energy consumption by designing the pump's BEP to customer duty point.
- Low NPSH values
- High suction lift
- Less civil works
- Low operating costs by appropriated material selections to the demanding water qualities. This includes the optional selection of duplex stainless steels.

- Space-saving vertical configurations reduce the footprint.
- Low maintenance requirements through reliable and proven pump designs.
- Back pull-out design for easy access.

## **Piston pump**

A piston pump is a type of positive displacement pump where the high-pressure seal reciprocates with the piston. Piston pumps can be used to move liquids or compress gases. They can operate over a wide range of pressures. High pressure operation can be achieved without a strong effect on flow rate. Piston pumps can also deal with viscous media and media containing solid particles.

Water Piston Pumps are the high-pressure piston pumps and are industry acknowledged as the most durable, most dependable pumps available. The designs as well as constructions of these products enable them to suffice as the highest quality pumps. These are reciprocating pumps, which come from the positive displacement pump family. These have been designed for high pressure pumping applications involving several liquids. Featured with piston as well as plunger, these display excellent suction capability, often not demanding flooded ingestion or booster pumps. Pumps are accessible with brass as well as stainless steel manifolds. The products are comprehended for flawless durability and consistent operation. These can

be employed to move liquids and can be operated over a wide ambit of pressures. Piston pumps, also called reciprocating pumps, can be powered by an electric motor, steam or a turbine, hydraulic drive mechanism. Piston pumps are capable of differential pressures up to 10,000 pounds per square inch (psi).

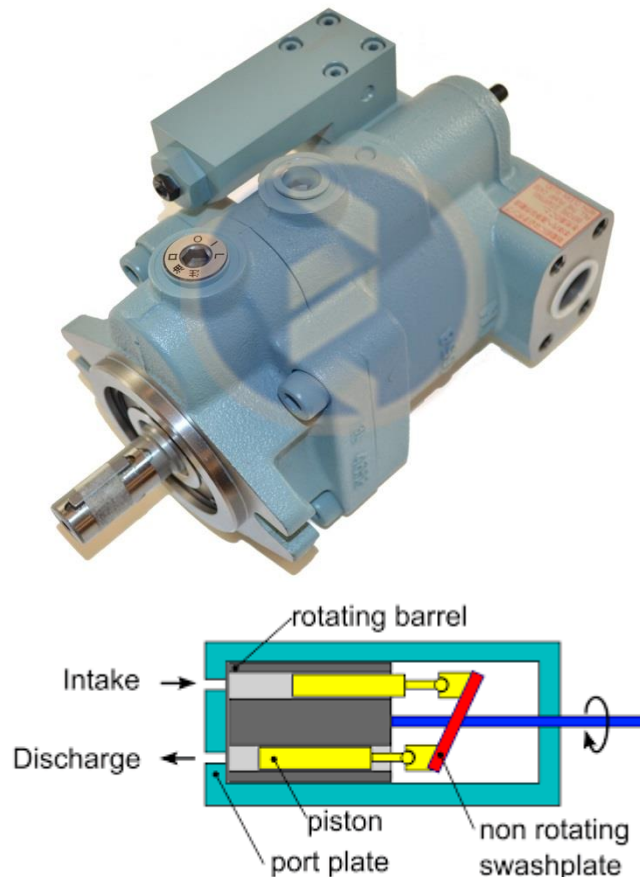

## Types

The two main types of piston pump are the **lift pump** and the **force pump**. Both types may be operated either by hand or by an engine.

## Advantages

Piston pumps have a wide pressure range, can reach high pressures and the pressure can be controlled without an impact on the rate of flow. Piston pumps have a continuous rate of discharge. Pressure changes and discharge rate have minimal effect on performance. Piston pumps can maneuver viscous fluids, high gas volumes and solids, only if the valves are correctly designed.

### **Disadvantages**

Piston pumps cost more per unit to run compared to centrifugal and roller pumps. The mechanical parts are prone to wear, so the maintenance costs can be high. The valves must be resistant to abrasives for large solids to pass through. Piston pumps are heavy due to their large size and the weight of the crankshaft that drives the pump.

### **Condition of pumps setup**

The rated condition is the operating point a pump is designed to operate at, and the primary condition at which operation is verified during a pump performance test.

### **Irrigation Methods:**

1. Surface Irrigation. Includes:

(A) Irrigation in basins. (B) Immersion (free). (C) Irrigation Furrow. (D) Ribbon irrigation.

2. Spray irrigation.
- 3- Drip irrigation.
- 4- Underwater irrigation.
- 5 - Wave water wave.
6. Supplementary irrigation.

**Choose the appropriate irrigation method:**

Failure to choose the proper irrigation method or excessive irrigation may cause:

- 1 - increase the burden on the systems drainage.
2. High cost of work.
- 3 - Increasing the capacity of waterways, which raises the cost of operation and maintenance.
4. Expect a decrease in pregnant women due to the washing of nutrients and poor ventilation.
5. High ground water level.

There are several methods of irrigation and the selection must be based on increasing irrigation efficiency and performance. Irrigation methods with characteristics and determinants can be divided as follows:

- 1- Surface Irrigation.
- 2- Sprinkler Irrigation.
- 3- Drip Irrigation.



#### 4- Subsurface Irrigation.

❖ Factors influencing the selection of suitable irrigation method:

1. Water-related factors: quantity of irrigation water, irrigation water quality, source of equipment, cost of water.

2. Soil factors: topography, soil type.

3. Plant factors: type of crop.

4. Climate factors: wind, rain, sun, heat, time.

5. Irrigation periods (irrigation frequency): Depends on soil storage for water, crop needs, climatic conditions.

6. Economic factors: the cost of the system and the settlement process.

7 - Other factors: mechanization, area, skill of farmers and workers, the cost of labor, the cost of the availability of irrigation equipment and spare materials and sources of energy and capacity.

#### **A. Surface irrigation method:**

Is the dominant system in most countries of the world and inherited for thousands of years, and means the addition of water to the surface of the earth to submerge and fall over it, after running part of it to the ground. This system is usually used when irrigation water is abundant because of the low efficiency of the irrigation system. If rapid water flow is

allowed on the surface of the earth, it may be feared that the land will not have enough irrigation water and vice versa if slow water is allowed on the surface He may be afraid to filter water far from the roots.

Surface irrigation types:

1- Flooding irrigation:

A) Irrigation in basins.

B) Free flow.

Irrigation is divided into:

1) Free Flooding.

2) Ribbon Irrigation Border-strip

C. Furrow and irrigation by Corrosion lines.

Surface irrigation features:

1. Low initial costs.

2 - a common and easy and known method of all.

3. Some crops are suitable for rice, fodder crops and cereals.

Suitable for washing salts from soil.

5. High discharges can be used for a few time periods.

6. Irrigation can be used for wide ranges of soil and crops with different discharges.

The most important determinants are:

1. The distribution of irrigation water, especially in highly permeable soils, is difficult to achieve.
2. It is not suitable for crops that require close and light irrigation.
3. It is determined by the topography of the Earth and requires good land settlement.
- 4 - the abundance of water rumors without the root area and increase evaporation.
5. Occurrence of erosion when the runoff is high.
6. It requires a large workforce and adequate control, measurement and distribution systems for water.

Several irrigation equipment are used for example:

- 1- Conversion pipes (immersed and submerged).
- 2- Siphon pipes.
- 3 - ordinary and electronic gates, openings and gates.
- 4 - Gates and organizations of regular and electronic alternating irrigation.
- 5- Electronic sensors used in field irrigation.

## **Subsurface Irrigation**

In sub-surface or sub-irrigation water is applied beneath the ground by creating and maintaining an artificial water table at some depth, usually 30 to 75 cm, below the ground surface. Moisture moves upwards towards the land surface through capillary action to meet requirements of the crops in plant roots. Water is applied through underground distribution system consisting of a properly designed main field ditches, laterals, laid 15 to 30 m apart.

The irrigation water is essentially required to be of good quality to prevent excessive soil salinity. The flow rate in supply ditches is required to be low to prevent waterlogging of the field. The use of sub-irrigation is limited because it requires certain soil condition that is the soil is permeable in root zone, underlain by an impervious horizon or high water table.

### **Essential Requirements**

The essential requirements for a successful sub-surface irrigation:

- (1) Availability of adequate supply of good quality water throughout growth period of the crop.
- (2) Fields must be nearly level and smooth. Ground slope is moderate. Land is approximately parallel to water table.
- (3) Availability of a layer of permeable soil such as sandy loam or loam immediately below the surface soil to permit free and rapid movement of water laterally and vertically.

(4) Availability of a relatively impervious layer at 2 to 3 m in the substratum to prevent deep percolation of water or a permanently high natural water table on which an artificial water table can be built.

(5) A well planned distributor system of main ditches, field laterals, etc., which raises the water table to a uniform depth below the ground surface over the entire area.

(6) Availability of adequate outlet for drainage of the area so irrigated particularly in humid areas.

(7) Soil is capable of lifting moisture from the water table to the root zone. Also the soil permits lateral and downward movement of water. The efficiency of water use depends on soil characteristics, topography and operation and maintenance management. In good system, the efficiency is 70-75 per cent.

## **Irrigation sprinkler**

An Irrigation sprinkler (also known as a water sprinkler or simply a sprinkler) is a device used to irrigate agricultural crops, lawns, landscapes, golf courses, and other areas. They are also used for cooling and for the control of airborne dust. Sprinkler irrigation is the method of applying water to a controlled manner in that is similar to rainfall. The water is distributed through a network that may consist of pumps, valves, pipes, and sprinklers. Irrigation sprinklers can be used for residential, industrial, and agricultural usage.



is a type of micro-irrigation system that has the potential to save water and nutrients by allowing water to spray slowly to the roots of plants, either from above the soil surface or buried below the surface. The goal is to place water directly into the root zone and minimize evaporation.

Irrigation Sprinkler System Parts:

- A. Water pump
- B. Water Meter
- C. Valve box
- D. Pipes (flexible or non-flexible pipes)

It can see following figures:



Figure : Irrigation equipment parts

### **Specific Advantages of Sprinklers:**

- More Irrigation with less water consumption
- Homogeneous water to all plants
- Controlled Irrigation like Natural Rain

- More Photosynthesis because leaves of plants are cleaned from dust & sunlight is directly affect to them so Yield is more
- Saving of Irrigation & Fertilization cost
- Yield is 15 to 40% more depending upon type of Crop
- No loss of water on Hills or Leakage
- Pipes are easy to install due to lighter weight and no chance of crop breakage

### **Drip irrigation**

Drip irrigation is a method of controlled irrigation in which water is slowly delivered to the root system of multiple plants. In this method water is either dripped onto the soil surface above the roots, or directly to the root zone. It is often a method chosen over surface irrigation because it helps to reduce water evaporation. Systems distribute water through a network of valves, pipes, tubing, and emitters. Depending on how well designed, installed, maintained, and operated it is, a drip irrigation system can be more efficient than other types of irrigation systems, such as surface irrigation or sprinkler irrigation.





## **Drip Irrigation System – Components**

A drip irrigation system consists essentially of mainline, sub mains, lateral, drippers, filters and other small fittings and accessories like valves, pressure regulators, pressure gauge, fertilizer application components etc.

### **Advantages of Drip Irrigation:**

1. Maximum use of available water.
2. No water being available to weeds.
3. Maximum crop yield.
4. High efficiency in the use of fertilizers.
5. Less weed growth and restricts population of potential hosts.
6. Low labour and relatively low operation cost.
7. No soil erosion.
8. Improved infiltration in soil of low intake.
9. Ready adjustment to sophisticated automatic control.

10. No runoff of fertilizers into ground water.
11. Less evaporation losses of water as compared to surface irrigation.
12. Improves seed germination.
13. Decreased tillage operations.